

Features

- Four independent arc fault tripping zones
- 1 or 2 arc fault sensors per zone allowing up to 8 arc fault sensors per 1S25 module
- Trip indication LED for each arc fault monitoring zone
- Non volatile memory ensures last recorded alarm states are restored on power up
- Nine (9) high speed arc fault tripping duty output contacts (Set for latching or self reset)
- Zone segregated or common tripping output configuration
- Continuous arc sensor supervision with sensor fail LED for each zone
- Wide range status input to block arc fault monitoring
- Front panel reset button & status input
- Self supervision watchdog with healthy LED & alarm contact
- Built in test sequence
- Wide range auxiliary supply

Introduction

Medium voltage switchgear is a key element in the power supply chain. Existing protection systems operate effectively under most circumstances, but they are too slow to handle arcing short circuits.

Arcing faults can occur as a result of insulation breakdown due to equipment age & / or poor maintenance.

The degree of damage caused by arcing depends principally on the duration of the arc. If an arc lasts only 100ms, the switchgear needs to be checked & the insulation resistance measured before power can be re-established. With a 200ms arc, the power supply will be interrupted; the switchgear must be checked; power is re-established only after minor repairs. In the event of a 500ms arc the supply is interrupted, metal parts of the switchgear are destroyed & poisonous gases are emitted. A 1s arc destroys most of the switchgear & may cause a fire, injury to personnel & damage to property.

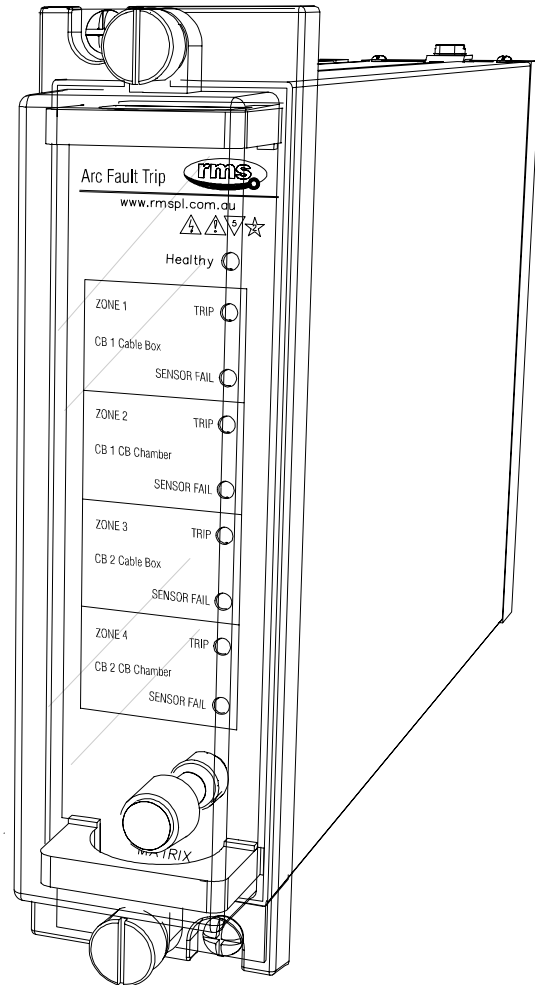

1S25 depicted in a 2M28-S draw out case with custom alarm text engraving

ARC Fault Protection

Made in Australia

Arc fault protection is a relatively new technique employed for the fast clearance of arcing faults on low voltage panels, MCC's, BUS bars & within metal clad switchgear & associated cable boxes. The arc is detected using an optical sensor & the signal input to a protection device which also monitors the load current on the system. A trip signal can be achieved in less than 10ms using arc detection only or within 15ms when using overcurrent check. This is considerably faster than a traditional IDMT overcurrent relay & provides additional protection from the onset of arcing faults with relatively low fault currents.

Arguably the greatest risk of arc fault damage exists at the CB cable termination & in the CB chamber itself due to the slow clearance times of the IDMT feeder protection. The CB cable termination is particularly at risk to ingress of moisture & rodent damage.

The problem of arc faults is most prevalent in older metal clad switchgear which already has operational protection systems. The 1S25 Arc Fault Monitor has therefore been designed for the following applications:

EXISTING SWITCHGEAR

Where a requirement exists to retrofit arc fault protection to metal clad switchgear utilizing the existing overcurrent protection relay;

NEW SWITCHGEAR

Where a requirement exists to install arc fault protection to new switchgear for integration with the customer preferred overcurrent feeder protection relay;

LOW VOLTAGE PANELS

Arc fault protection may also be applied on low voltage panel control boards & motor control centers (MCC's).

ARC FAULT PROTECTION

The over-current caused by an arc is, due to its resistance, lower than the over-current caused by a “metallic” short circuit. The over-current caused by the arc may also be lower than the protection start current when energising circuits or starting large motors. The consequence of these conditions is that a protection system based solely on over-current detection cannot effectively discriminate between normal system currents & an arc fault condition:

- For moderate arc fault currents the trip time of the over-current IDMT stage will be too slow;
- For very low arc fault currents the instantaneous trip stage of a standard over-current relay cannot be set low enough.

SWITCHGEAR ARC PROTECTION

The risk of arc fault damage exists at the CB cable termination & in the CB chamber itself. The CB cable termination is particularly at risk to ingress of moisture & rodent damage.

The 1S25 Arc Fault Monitor provides four (4) independent tripping zones with one or two arc sensors per zone as depicted in the single line application diagrams at right.

Figures 1 & 2 depict arc protection of up to four feeder circuits with a single 1S25 as independent zones. A trip signal will be initiated to the circuit breaker in the event of an arc fault occurring at the sensor(s) within its zone provided the overcurrent relay starter contact is picked up. In these applications the overcurrent check stage is optional as the consequence of a single feeder outage is less than the loss of an entire BUS.

Figure 3 shows an application where a 1S25 is applied for the protection of the Cable box, CT chamber & CB chamber across two feeder circuits (Zones). In this configuration one arc trip zone is used to trip the feeder circuit breaker in the event of an arc fault in the cable box or CT chamber. The second zone trip output is wired to trip the upstream BUS breaker (BUS overcurrent check not shown), in the event of an arc fault in the CB chamber.

EXISTING SWITCHGEAR APPLICATIONS

The existing overcurrent relay protecting the feeder will normally provide an independent output contact associated with the start current setting of the relay. That is an output contact that will close when a phase or earth fault current is detected above the threshold which starts the internal relay timers. This starter element should be set for instantaneous operation so that it will pick up in the order of 15ms.

An Arc Fault Monitor relay 1S25 is installed on the switchgear panel adjacent to the protection relay.

1S30 optical arc sensors are fitted in the cable termination box & CT chamber as depicted in figure 2.

The overcurrent relay starter contact may optionally be wired in series with the arc fault detection trip output contact as depicted in figure 8. The resulting “AND” function trip output is wired to trip the breaker in ~15ms in the event that an arc fault is detected while the overcurrent start element is picked up.

The common arc trip & fail alarm contacts may be employed for interface to a SCADA system for fault reporting.

NEW SWITCHGEAR APPLICATIONS

For new switchgear installations a modern numeric feeder protection relay is likely to be employed which will have numerous programming & configuration options.

The basic concept is the same as for the existing switchgear application described above except that the additional features & flexibility of modern feeder protection relay allows improved system integration.

This may be achieved by using the common arc trip output contact to interface to a programmable status input on the feeder protection relay. Depending on the model of protection relay being used this input may be programmed to provide an alarm message on the HMI, time stamped event record available via its communications link.

Switchgear Applications

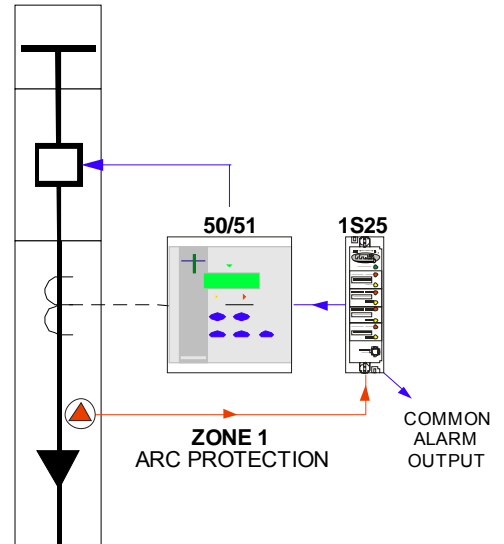

Figure 1: Single arc sensor per zone 1 - Cable box

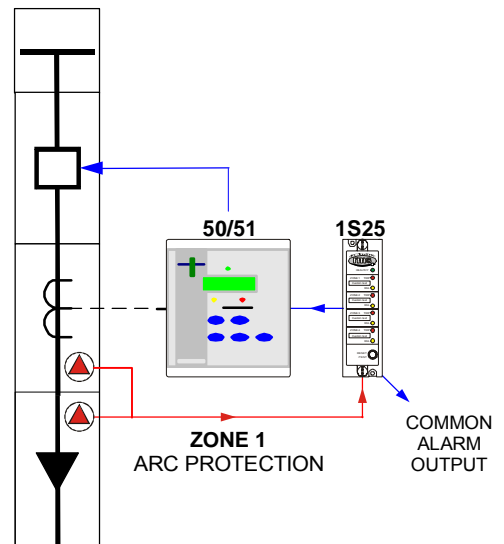

Figure 2: Two arc sensors per zone - Cable box & CT chamber

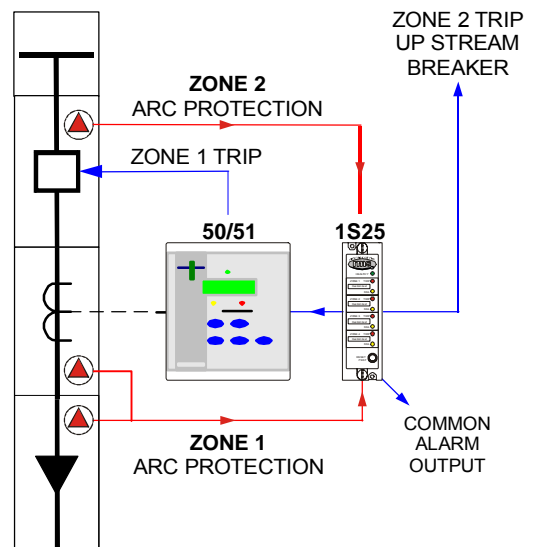

Figure 3: Two arc sensors in zone 1 - Cable box & CT chamber
One or two arc sensors in zone 2 for CB chamber

BUS Bar Applications

COMBINED BUS BAR & SWITCHGEAR ARC PROTECTION

Figure 4 shows an application where a single 1S25 is applied for the protection of a feeder Cable box & CT chamber plus the CB chamber & BUS chamber using up to eight arc sensors over four zones. In this configuration one arc trip output is used to trip the feeder circuit breaker in the event of an arc fault in the cable box / CT chamber. Zone 2, 3 & 4 trip outputs are used to trip the BUS breaker (BUS overcurrent check stage not shown), in the event of an arc fault in the CB chamber or BUS chamber.

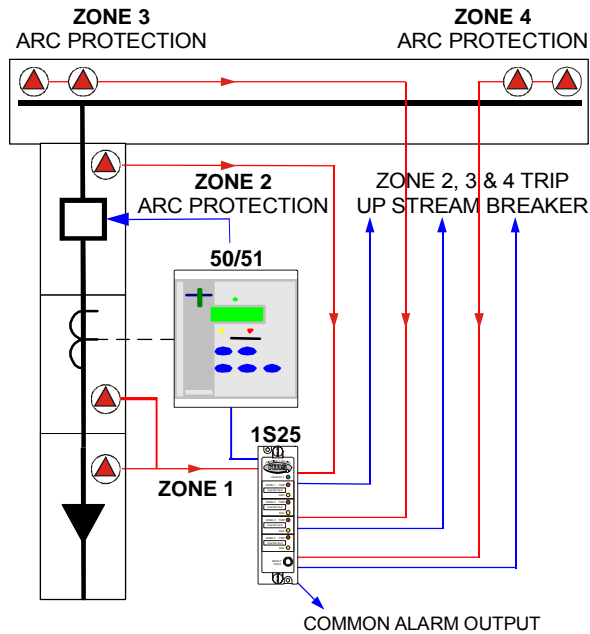

Figure 4: Two arc sensors in zone 1 - Cable box & CT chamber
One or two arc sensors in zone 2 for CB chamber
One or two arc sensors in zone 3 for BUS chamber
One or two arc sensors in zone 4 for BUS chamber

BUS BAR ARC PROTECTION

Figure 5 depicts how the 1S25 may also be applied for the protection of bus bars. The number of sensors in the bus chamber is dictated by the switchgear design and the length of switchboard.

In most indoor metal clad switchgear the bus bar chamber is a continuous chamber between panels only broken into segregated sections at a bus section breaker & as such the strategic placement of one or two arc sensors in each bus bar chamber run is normally adequate.

Some indoor metal clad switchgear may segregate the bus chamber of each panel from the next via insulated bus chamber side barriers per panel, if this is the case then each bus chamber per panel would need to be monitored by at least one arc sensor.

Isolating switches between BUS bar sections need also be considered & appropriate tripping zones created to ensure isolation of the faulted section.

In large enclosures the arc sensors should be placed at approximately 5m intervals. 1S30 arc sensors are also available with dual optical detectors to allow detection of arc in both directions.

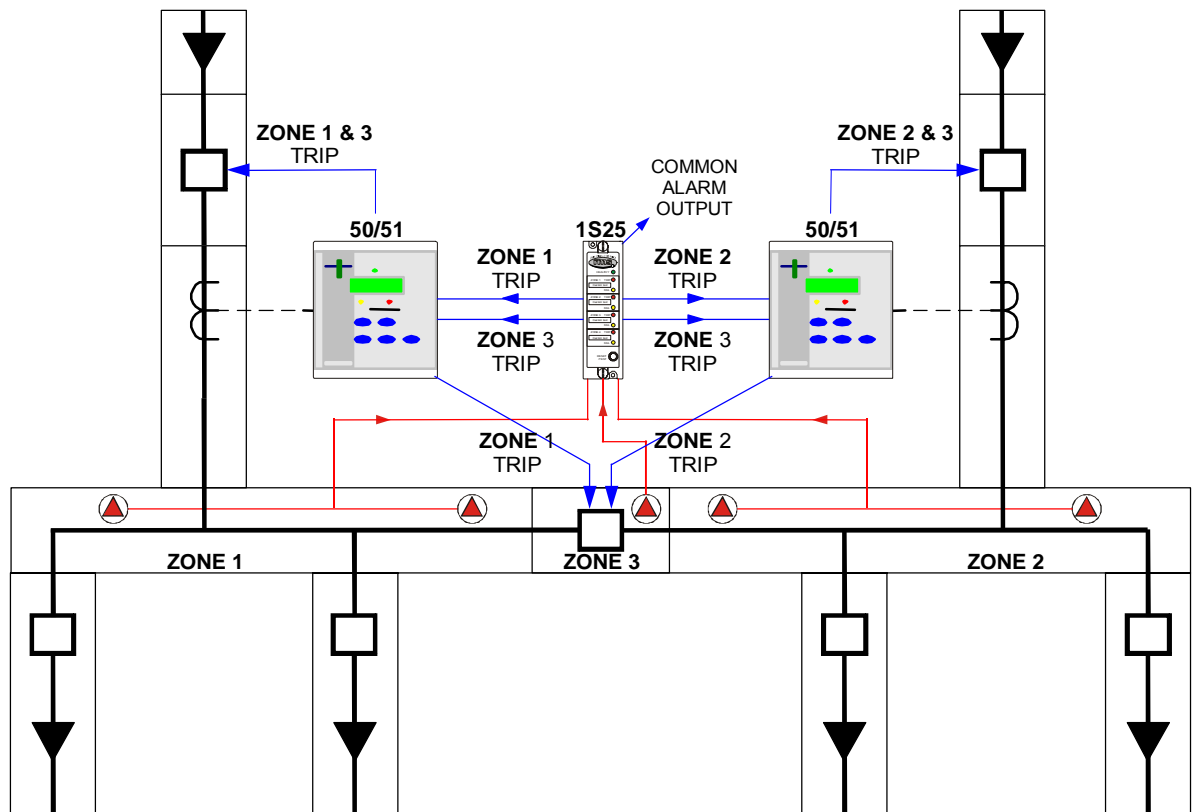

Figure 5: One to eight arc sensors located in the BUS chamber in up to four tripping zones

Low Voltage Applications

LOW VOLTAGE ARC PROTECTION

Figures 6 & 7 depict how the 1S25 may also be applied for low voltage panels & MCC switchgear.

Figure 6 depicts an arrangement where over current check stage is employed while the protection application depicted in figure 7 is a system based solely on arc detection.

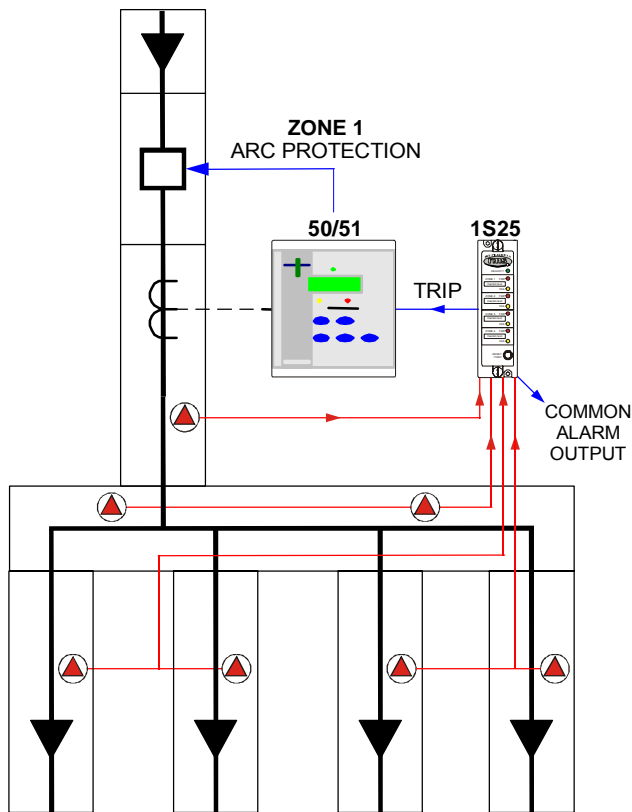

Figure 6:
Up to eight arc sensors distributed in low voltage switchgear.
Over current check stage depicted.

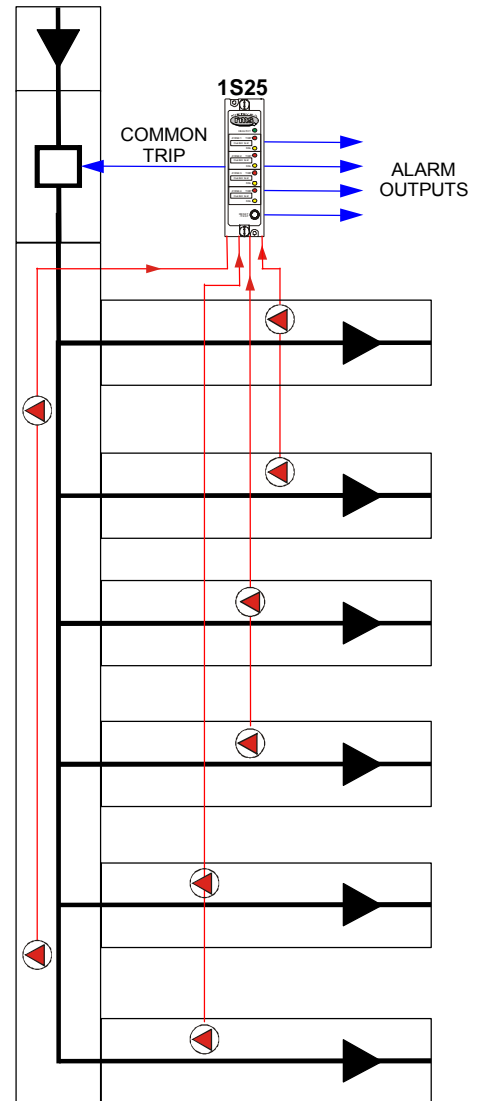

Figure 7:
Up to eight arc sensors distributed in low voltage switchgear or
MCC compartments without over current check

OPERATION INDICATOR

Two (2) LED's are provided for each tripping zone to provide the following status indications:

Trip: Flashes for 2s on detection of arc fault in zone & then solid
Resets when front panel reset button pressed or voltage pulse applied to remote status input.

Fail: Flashes to indicate failure of 1S30 Arc Fault Sensor in zone.



CONFIGURATION SWITCHES

Three banks (A, B & C), of four (4) configuration switches are accessible to the user by first withdrawing the relay module from the outer case.



CONFIGURATION SWITCH SETTINGS

The internal wiring label identifies the position of the following switch functions as follows:

Switch	ON	OFF
A1	Zone 1 Arc sensor fitted	Zone 1 Arc sensor not fitted
A2	Zone 2 Arc sensor fitted	Zone 2 Arc sensor not fitted
A3	Zone 3 Arc sensor fitted	Zone 3 Arc sensor not fitted
A4	Zone 4 Arc sensor fitted	Zone 4 Arc sensor not fitted

Switch	ON	OFF
B1	Zone 1 – 2 Arc sensors	Zone 1 – 1 Arc sensor
B2	Zone 2 – 2 Arc sensors	Zone 2 – 1 Arc sensor
B3	Zone 3 – 2 Arc sensors	Zone 3 – 1 Arc sensor
B4	Zone 4 – 2 Arc sensors	Zone 4 – 1 Arc sensor

Switch	ON	OFF
C1	Latching trip contacts	Self reset trip contacts
C2	Independent trip outputs	Common trip outputs
C3	Apply volts to BLOCK	Remove volts to BLOCK
C4	DC only status inputs	AC/DC status inputs

ARC SENSOR CIRCUIT SUPERVISION

The 1S30 Arc Sensor is the heart of the system & supervision of circuit continuity is critical for correct operation. To monitor the integrity of the wiring between the 1S30 arc sensor & 1S25 Arc Monitor, a continuous 2mA supervision current flows between the units.

The 1S25 alarm contact will drop out after a 1s time delay if it fails to detect this current.

The failed zone will be indicated by the front panel 'Sensor fail' LED.

ARC SENSOR FUNCTION

The 1S30 is an optical sensor that responds to the flash of light emitted during the incidence of an arcing fault. Onset of the light flash & detection by the 1S30 occurs in a few ms.

When an arc is detected, the resistance presented by the 1S30 drops to a level where the current flow increases to approximately 20mA. This increased current flow is instantaneously detected by the 1S25 & its trip output contacts closed. Refer to the 1S30 Technical Bulletin for further details.

ARC FAULT TRIPPING USING CURRENT CHECK

Fast operation of a tripping scheme usually results in reduced system security. The arc detection method can however, combine the 1S25 optical detection technique with a traditional overcurrent method to maximize system security particularly for BUS bar protection schemes. Both conditions must coexist for the trip condition to be met as depicted in figure 8.

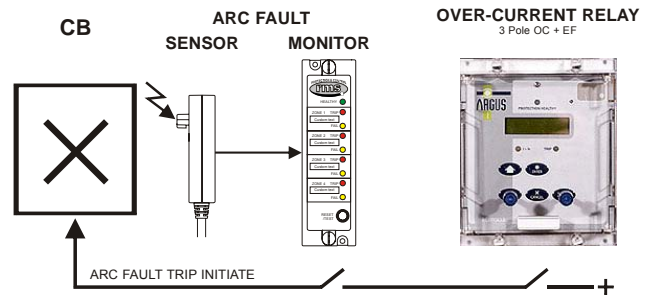

Figure 8:
Key components required to implement an Arc Fault Protection scheme with an overcurrent check stage to enhance system security

The application examples in figures 1 to 5 utilize this concept for enhanced system security in that both the 1S25 AND the OC 50 starter contact must be picked up for a CB trip signal to be initiated. As the arc fault trip contact picks up considerably faster than the overcurrent relay starter element, the CB trip time will be dictated by the overcurrent relay performance.

LOW CURRENT ARCING FAULTS

Arcing faults can occur at low current levels & it is possible for the over-current starter element to be set above this level. To avoid this problem & obtain very fast clearance (<10ms), of an arc fault, the 1S25 arc fault trip contact may be wired directly to the breaker operate coil. It should be noted that this method may lead to reduced system security.

ARC DETECTION RESET TIME (Effect of multiple arc trips)

A delay of 2s is required to reset the 1S25 after an initial arc sensor trip. Subsequent arc detection will cause the trip output contacts to re-operate.

INDEPENDENT TRIP OUTPUT CONTACTS

The 1S25 provides up to four (4) tripping zones each with an independent tripping output. Alternatively configuration switch C2 can be set to OFF so that all trip outputs will operate in the event of an arc being detected by any sensor.

ARC SENSOR CONTINUOUSLY PICKED UP

High ambient light levels may cause a 1S30 to be continuously picked up. This condition could occur for example if the CB cable box cover was left open in very high ambient light level conditions. A non arc fault over-current pick up would then result in an arc fault trip operation.

To avoid possible mal operation due to this condition, the 1S25 is designed to automatically disable the arc fault tripping function if the 1S30 sensor is picked up for >10s. The 1S25 alarm contact will be set & the front sensor fail LED will flash until the ambient light level problem is corrected. The 1S25 will then perform an arc sensor test function & automatically reset.

The failed zone will be indicated by the front panel 'Sensor fail' LED.

AUXILIARY SUPPLY

A high efficiency switchmode power supply is incorporated which provides a low burden to the auxiliary supply.
 Low range model: 20-70V DC
 High range model: 40-300V DC & 40-275V AC

AUXILIARY SUPPLY BURDEN (At 110V DC)

Quiescent: Less than 4W
 Maximum: Less than 10W

OPERATING TIME OF ARC FAULT DETECTION

Arc fault trip contacts guaranteed to pick up in less than 10ms including bounce. Typical operate time is 7ms.
 Reset time of the arc fault element is 2s.

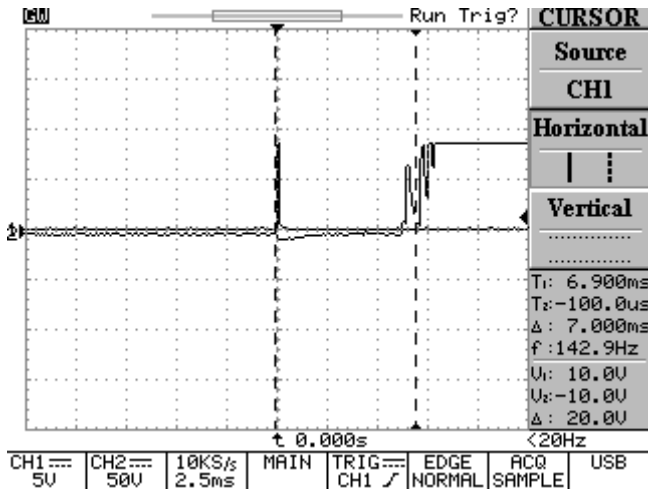

CRO trace showing nominal operation time of the trip contacts at 7ms. First contact touch at 6.25ms and fully closed by 7.25ms. Operation in <10ms is considered acceptable as current check relay operate time is ~15ms.

FRONT PANEL LED'S

Green system healthy LED
 Arc Trip - One red LED per zone - off, flashing or on solid
 Sensor Alarm - One red LED per zone - off, flashing or solid

ARC FAULT BLOCK STATUS INPUT DELAY

Initiate input	Minimum	AC Rejection Filter	
		ON	OFF
DC	P/U	<16ms	<4ms
	D/O	<4ms	<16ms
AC	P/U	N/A	<23ms
	D/O	N/A	<33ms

Table 1

STATUS INPUT OPERATING VOLTAGE

An internal configuration switch is provided to select status input operation for DC only or AC/DC. This setting may be pre defined when ordering.

18 - 300V DC Set Configuration Switch to **ON**
 In this mode the universal status input will reject AC signals that may be induced on the control wiring. Suitable for high security applications where a DC battery supply is available.

18 - 300V DC & 18 - 275V AC Set Configuration Switch to **OFF**
 In this mode the universal status input is designed to operate on both AC & DC input voltages. Suitable for applications where an AC auxiliary voltage is available such as transformer or generator control panels.

STATUS INPUT MINIMUM OPERATING CURRENT

10mA P/U for 1ms then reducing to 1.5mA after 4ms.

RESET

Press the front reset button or pulse the reset status input.

OUTPUT CONTACTS

Tripping contacts: 8 - 2 N/O per tripping zone
 Common tripping contact: 1 N/O
 Fail alarm: 1 C/O contact for the power supply / CPU fail / arc fault sensor.
 Normally picked up & drops out to signal an alarm condition.

OUTPUT CONTACT RATINGS

IEC60255-0-2

Carry continuously 5A AC or DC
 Make & carry 0.5s 20A AC or DC
 L/R ≤ 40ms & V ≤ 300V
 AC resistive 1,250VA
 Break capacity AC inductive 250VA @ PF ≤ 0.4
 DC resistive 75W
 DC inductive 30W @ L/R ≤ 40ms
 50W @ L/R ≤ 10ms
 Minimum number of operations 10⁶ at maximum load
 Minimum recommended load 0.5W limit 10mA / 5V

TRANSIENT OVERVOLTAGE

IEC60255-5

Between all terminals & earth 5kV 1.2/50us 0.5J
 Between circuit groups: 5kV 1.2/50us 0.5J
 Status/Reset Inputs, Auxiliary Supply, Sensor Inputs, Trip Outputs
 Without damage or flashover

INSULATION COORDINATION

IEC60255-5

Between all terminals & earth 2.0kV RMS for 1 minute
 Between circuit groups: 2.0kV RMS for 1 minute
 Status/Reset Inputs, Auxiliary Supply, Sensor Inputs, Trip Outputs
 Across normally open contacts 1.0kV RMS for 1 minute

AUXILIARY SUPPLY

IEC60255-11

Allowable breaks / dips in supply ≤ 20ms
 Collapse to zero from nominal voltage

HIGH FREQUENCY DISTURBANCE

IEC60255-22-1 CLASS III

2.5kV 1MHz common mode No mal operation
 1.0kV 1MHz differential mode

ELECTROSTATIC DISCHARGE

IEC60255-22-2 CLASS III

6kV contact discharge No mal operation

RADIO FREQUENCY INTERFERENCE

IEC60255-22-3

10V/m, 80 TO 2,700MHz No mal operation

FAST TRANSIENT

IEC60255-22-4

4kV, 5/50ns, 100KHz repetitive No mal operation

CONDUCTED RFI

IEC60255-22-6

10V, 0.15 to 80MHz No mal operation

CUSTOM ALARM TEXT - Refer ordering information page.

Maximum characters: 2 lines x 15 characters / tripping zone.
 Maximum font size: 1 line x 10 characters / tripping zone.

TEMPERATURE RANGE

IEC68-2-1/2

Operating: -5 to +55°C
 Storage: -25 to +75°C

HUMIDITY

IEC68-2-78

40°C & 95% RH non condensing

TERMINATION SCREWS

M4 Screws

An M4 screw kit is supplied as standard with each 1S25. Additional M4 screw kits may be purchased separately.

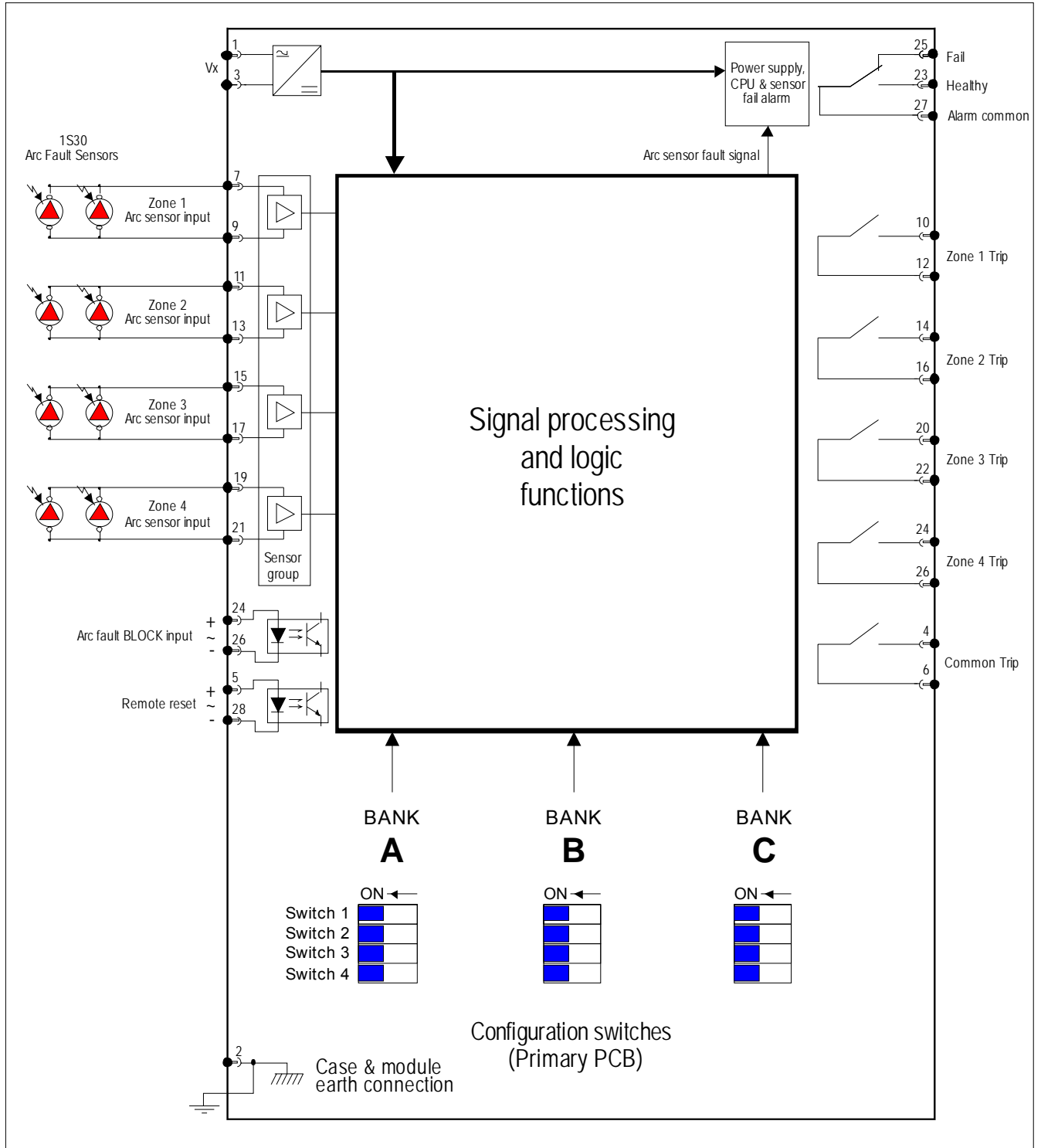

Figure 9: Wiring diagram for 1S25 four zone arc fault monitor - Relays shown in de-energized condition

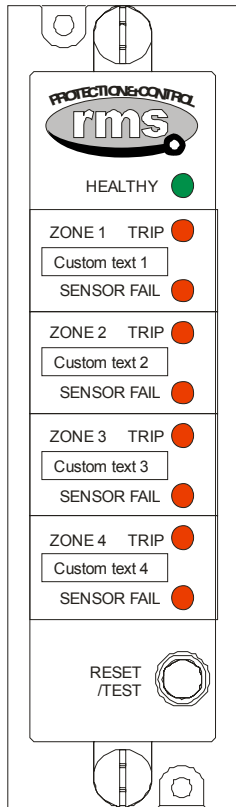

Figure 10: Alarm text position layout

Case Mounting

CASE
2M28-S draw out case

ACCESSORIES SUPPLIED WITH EACH RELAY

- 1 x M4 self threading mounting screw kit P/N 290-406-151
- 2 x M4 terminal screw kit (28 per kit) P/N 290-407-153
- 1 x Product Test Manual

1S30 ARC FAULT SENSORS

Refer to the 1S30 Technical Bulletin for details.



Figure 11: 1S30 Arc Fault Sensors
Through panel mounting detector version depicted at left
Front panel view of dual detector version depicted at right

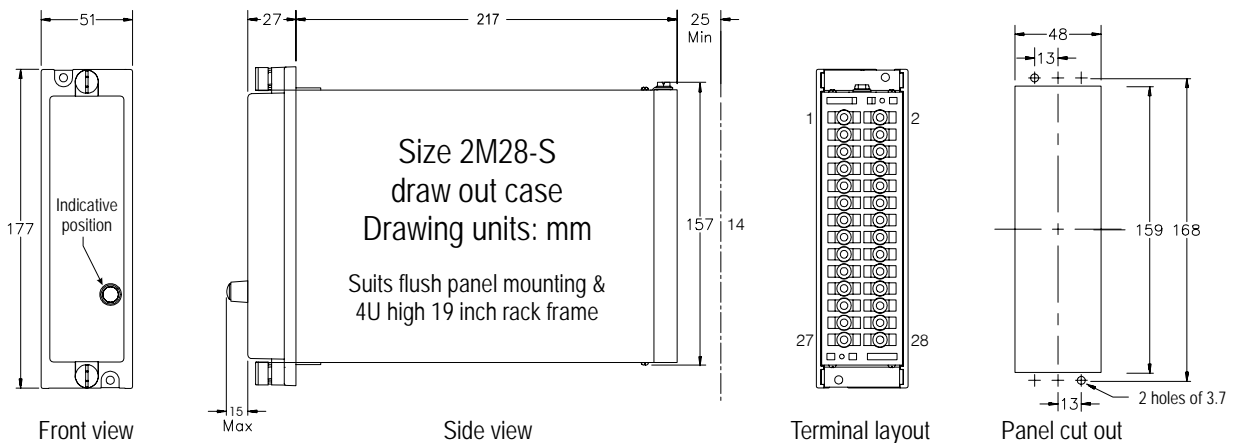

Figure 12: Case mounting details 8 point alarm version



ALARM TEXT LABELS

The 1S25 front panel has provision for custom text to identify the sensor location for each arc fault tripping zone. The required text may be engraved on the front panel by the factory if specified at time of order. Alternatively the front panel may be removed for engraving by the user or contractor. The RMS web site provides an ACAD file for this purpose.

The front panel is fabricated from flexible plastic sheet with a white surface & black substrate to provide high contrast black text when engraved.

Removal of the front label is achieved by drawing out the 1S25 module from the outer case & pulling the label from the edges at the mid point between the top & bottom draw out handles. This will cause the label to bend & disengage from the top & bottom handle retention points. Once free from the 1S25 module the front label can be placed on an engraving table. Additional factory engraved labels may be sourced from RMS for later field installation.

While an engraved label provides the most permanent record other methods such as laser printed stick on labels or indelible marker pen may be satisfactorily employed.

CUSTOM ENGRAVED TEXT DEFINITION

Complete the following tables with one character per box. Refer to the front panel layout depicted in figure 10. Submit completed labeling information with the 1S25 product ordering code. For maximum font size limit text for each alarm point to 1 line x 10 characters.

Text will be left justified.

Zone 1

Zone 2

Zone 3

Zone 4

Ordering Information

ORDER CODE

The order code determines the production build in the factory & cannot be changed in the field.

Generate the required order code as follows: e.g. 1S25 BA

General Type	Order Code	
	1	2
1S25	-	

1 AUXILIARY SUPPLY RANGE

- A 20 - 70V DC
- B 40 - 300V DC & 40 – 275V AC

2 CUSTOM ENGRAVED TEXT

- A Not required No engraving - factory default
- B Required Complete the custom text details at left

CONFIGURATION CODE (Optional specification)

The configuration code can be set in the field by withdrawing the relay module & following the instructions on the side plate label.

The configuration code may be specified at time of order so that the relay will be shipped from the factory pre-set to meet customer requirements. e.g. CONFIG-0101-0101-1111

If a configuration code is not specified the factory default will be set as indicated below. i.e. CONFIG-1111-1111-1111

Specify Factory Configuration	Configuration Switches			
	A1	A2	A3	A4
CONFIG	-			
		B1	B2	B3
	-			
		C1	C2	C3
	-			

A1-4 ZONE 1 - 4 SENSOR INPUTS

- 1 ON Arc sensor(s) connected (Default)
- 0 OFF No sensor connected

B1-4 ZONE 1 - 4 SECOND SENSOR

- 1 ON Second sensor connected (Default)
- 0 OFF Single sensor only

C1 OUTPUT CONTACTS FUNCTION

- 1 ON Latching (Default)
- 0 OFF Self reset

C2 OUTPUT CONTACTS GROUPING

- 1 ON Segregated zone tripping outputs (Default)
- 0 OFF Common outputs

C3 ARC FAULT INITIATE INPUT FUNCTION

- 1 ON Apply volts to BLOCK arc detection (Default)
- 0 OFF Remove volts to BLOCK arc detection

C4 STATUS INPUT AC REJECTION

- 1 ON DC operation only - AC rejection ON (Default)
- 0 OFF AC / DC operation - AC rejection OFF



Australian Content

Unless otherwise stated the product(s) quoted are manufactured by RMS at our production facility in Melbourne Australia. Approximately 60% of our sales volume is derived from equipment manufactured in house with a local content close to 90%. Imported components such as semi-conductors are sourced from local suppliers & preference is given for reasonable stock holding to support our build requirements.

Quality Assurance

RMS holds NCSI (NATA Certification Services International), registration number 6869 for the certification of a quality assurance system to AS/NZS ISO9001-2008. Quality plans for all products involve 100% inspection and testing carried out before despatch. Further details on specific test plans, quality policy & procedures may be found in section A4 of the RMS product catalogue.

Product Packaging

Protection relays are supplied in secure individual packing cardboard boxes with moulded styrene inserts suitable for recycling. Each product & packing box is labeled with the product part number, customer name & order details.

Design References

The products & components produced by RMS are based on many years of field experience since Relays Pty Ltd was formed in 1955. A large population of equipment is in service throughout Australia, New Zealand, South Africa & South East Asia attesting to this fact. Specific product & customer reference sites may be provided on application.

Product Warranty

All utility grade protection & auxiliary relay products, unless otherwise stated, are warranted for a period of 24 months from shipment for materials & labour on a return to factory basis. Repair of products damaged through poor application or circumstances outside the product ratings will be carried out at the customer's expense.

Standard Conditions of Sale

Unless otherwise agreed RMS Standard Terms & Conditions (QF 907) shall apply to all sales. These are available on request or from our web site.



Relay Monitoring Systems Pty Ltd

6 Anzed Court, Mulgrave, Victoria 3170, AUSTRALIA

Tel: 61 3 9561 0266 Fax: 61 3 9561 0277 Email: rms@rmspl.com.au Web: www.rmspl.com.au