

Features

- Large size push buttons
- High visibility CB status LED's
- Suitable for 24, 32, 48, 110/125 & 240/250V DC supplies
- Optional CB spring charge status LED
- Standard panel cover
- Optional locking cover
- Heavy duty output contacts
- Optional custom engraving
- Optional lamp test button & output contact
- Optional integrated control circuit steering diodes
- Rugged construction
- 4U rack or flush mounting
- Size 2M draw out case

Application

Modern digital feeder relays provide a wide range of protection & control functions. Programming is achieved via a programming port or operator interface (HMI) usually located on the front panel.

The HMI may also incorporate user programmable push buttons for functions such as CB Trip, CB Close, & maintenance mode.

While low cost these push buttons are normally small, not very robust & rely on the relays CPU & auxiliary supply for correct operation. The auxiliary contacts controlled by the push buttons are also not particularly robust & cannot be relied upon to break the inductive DC load presented by the CB coil.

As the primary role of these push buttons is to function independently & under abnormal system conditions a more secure configuration is desirable.

The 1X50 CB Trip & Close Module meets these requirements while at the same time providing a range of useful & innovative features to operate & monitor circuit breaker (CB) performance.



1X50 depicted in a 2M28 case

Description

Made in Australia

The 1X50 Trip & Close Module has been designed to provide a cost effective & feature rich solution for the manual control & indication of CB status. The panel or rack mount configuration allows the compact 1X50 to be located on the protection panel adjacent to the feeder protection relay.

22mm heavy duty push buttons are employed for the CB Trip & Close functions while two LED's are employed for CB status indication. An additional status input is available to provide an LED indication when the CB close spring is charged.

The trip & close buttons control heavy duty output contacts which are suitable for application on all nominal system voltages up to 250V DC.

An optional locking cover is available to preclude unauthorised operation of the trip & close buttons during maintenance activities for example.

Four (4) steering diodes & lamp test button are integrated in the 1X50 as a convenient & space saving option for application in external control wiring.

A more advanced version, the 1X60, is under development which will incorporate a number of additional innovative features:

- Time delayed CB trip or close 'safety' function
- CB operation counter
- CB operation counter with count preset & alarm output contact
- Trip circuit supervision
- Trip supply supervision
- Trip relay coil supervision
- Trip relay contact arc suppression protection circuit

TRIP BUTTON OUTPUT CONTACTS

The trip push button has two associated auxiliary contacts. These may be specified with an optional arc suppression circuit to enhance inductive DC break capacity at higher DC voltages.

CLOSE BUTTON OUTPUT CONTACTS

The close push button has two associated auxiliary contacts. These may be specified with an optional arc suppression circuit to enhance inductive DC break capacity at higher DC voltages.

LOCKING COVER (OPTION)

This option should be specified at time of order to ensure the standard cover is fitted with the required retention screws & locking bar. A user supplied locking device of appropriate size may then be installed to prevent the front cover retention screws from being operated so that the cover cannot be removed. In this state the trip & close buttons remain inaccessible to stop unauthorised operation.

Various locking devices may be employed such as a padlock or wire seal. An important design feature is that the CB status open & close LED's remain visible at all times.

Padlock Locking Device

- Shank diameter: <4.5mm
- Shank length: 25mm
- Body size: 25 x 25mm to 30 x 30mm
- Recommended: Lockwood 110/25/119 or similar
- Refer: www.rmspl.com.au/handbook/1x50padlock.pdf

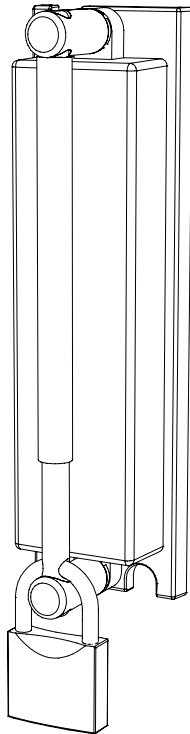

Figure 1:
Optional Padlock Cover

TRIP BUTTON

- Size: 22mm
- Colour: Red - Standard [x][A][x] -
- Green - Optional [x][B][x] -
- Function: Momentary self reset

CLOSE BUTTON

- Size: 22mm
- Colour: Green - Standard [x][A][x] -
- Red - Optional [x][B][x] -
- Function: Momentary self reset

CB CLOSED STATUS INDICATION

- Size: 5mm
- Colour: Green LED - Standard [x][A][x] -
- Red LED - Optional [x][B][x] -

CB OPEN STATUS INDICATION

- Size: 5mm
- Colour: Red LED - Standard [x][A][x] -
- Green LED - Optional [x][B][x] -

SPRING CHARGE STATUS INDICATION (OPTION)

- Size: 5mm
- Colour: White LED
- Spring charged: LED ON
- Spring free: LED OFF

LAMP TEST BUTTON (OPTION)

An optional lamp test button is available for checking the integrity of the 1X50 LED's. A repeat voltage free output contact is provided to interface with external lamp test circuits.

- Contact: 1 N/O
- Function: Follows 1X50 test button - Self reset
- Rating:

Carry continuously	5A AC or DC
Make & carry	0.5s 20A AC or DC
L/R ≤ 40ms & V ≤ 300V	0.2s 30A AC or DC
Break capacity I ≤ 5A & V ≤ 300V	AC resistive 1,250VA
	AC inductive 250VA @ PF ≤ 0.4
	DC resistive 75W
	DC inductive 30W @ L/R ≤ 40ms
Minimum number of operations	10 ⁶ at maximum load
Minimum recommended load	0.5W limit 10mA / 5V

CONTROL CIRCUIT STEERING DIODES (OPTION)

While not related to the primary trip & close function of the 1X50, four steering diodes are provided as an optional feature for application in associated protection control circuits. This is a convenient & space saving feature to avoid the need to fit & wire external components.

- Number: 4 independent diodes
- Type: IN4007
- Rating: 1,000V / 1A

OPERATING BURDEN

Under normal operating conditions either the CB Open or CB Closed status LED's are continuously energized. The operating burden of the 1X50 is dependent on the nominal operating voltage:

24V DC	<1W
32V DC	<1W
48V DV	<1W
110/125V DC	<3W
240/250V DC	<5W

The operating burden is doubled when the Spring Charge LED is illuminated.

CASE

Size 2M28-S draw out
28 M4 screw terminals
Flush panel mount or 4U high 1/8 width 19 inch rack mount

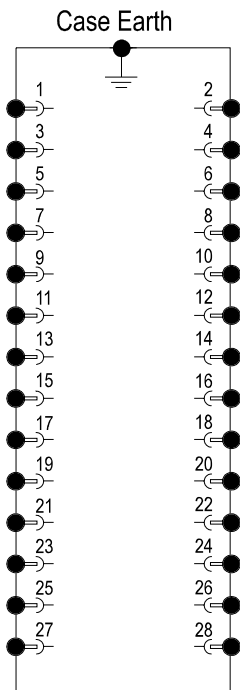

Case terminations (REAR VIEW)

TRIP / CLOSE OUTPUT CONTACT RATINGS

The following contact ratings are applicable for the standard 1X50 without the arc suppression option.

Contact plating material	Silver	
Maximum inrush current	40A (40ms)	
Carry continuously	10A AC or DC	
Contact ratings by utilization category	AC-15 (A600) DC-13 (P600)	
Minimum recommended load		5mA @ 3V AC/DC
Initial contact resistance		<0.05 ohm
Contact gap (N/O)		4mm

INDUCTIVE DC BREAK RATINGS

Standard Contacts

System Voltage	24V DC	48V DC	110V DC	250V DC
Operation Current	5A	2A	1.1A	0.5A

TRANSIENT OVERVOLTAGE

Between all terminals & earth	IEC60255-5 CLASS III 5kV 1.2/50us 0.5J
Between independent circuits without damage or flashover	5kV 1.2/50us 0.5J

INSULATION COORDINATION

Between all terminals & earth	IEC60255-5 CLASS III 2.0kV RMS for 1 minute
Between independent circuits	2.0kV RMS for 1 minute
Across normally open contacts	1.0kV RMS for 1 minute

EXTERNAL SHORT CIRCUIT PROTECTION

Fuse: 10A 250V conforming to IEC60269-1

TEMPERATURE RANGE

Operating:	IEC68-2-1/2 -5 to +55°C
Storage:	-25 to +75°C

HUMIDITY

40 °C & 95% RH non condensing	IEC68-2-78
-------------------------------	-------------------

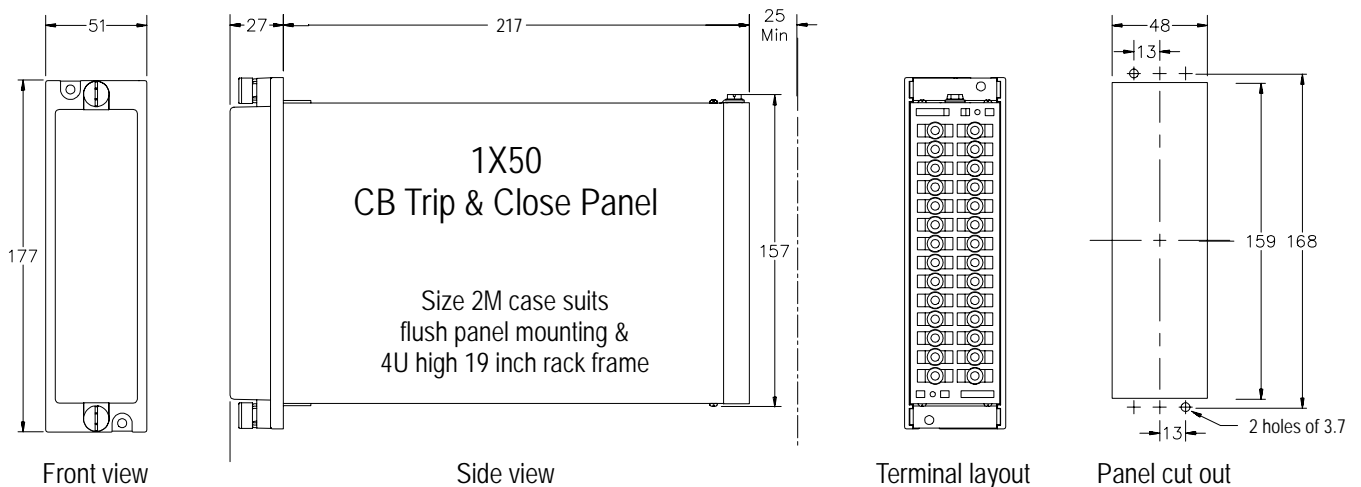

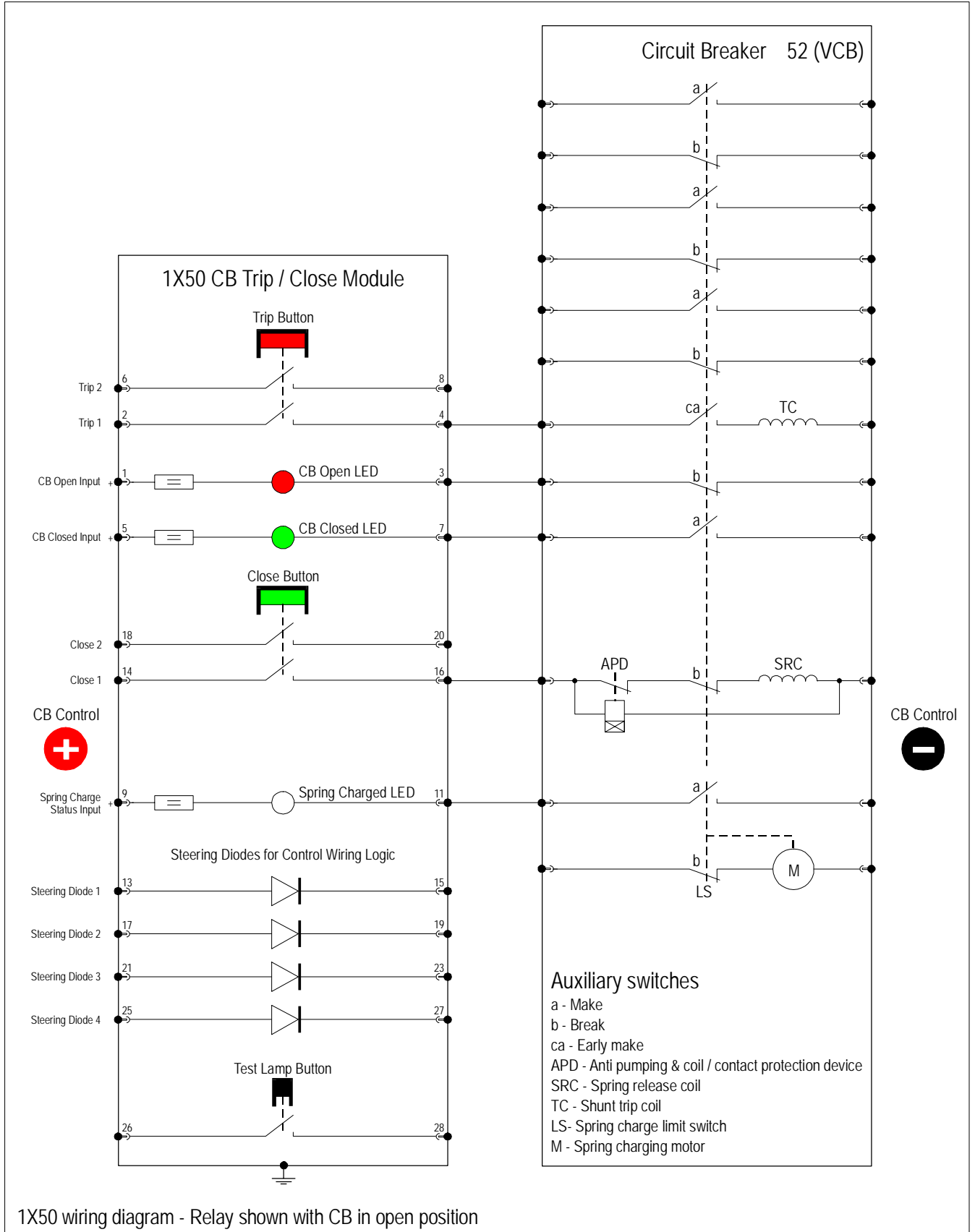

Figure 2:
1X50 CB Trip & Close Module Terminal Definition
Typical MV Switchgear Application

Ordering Information

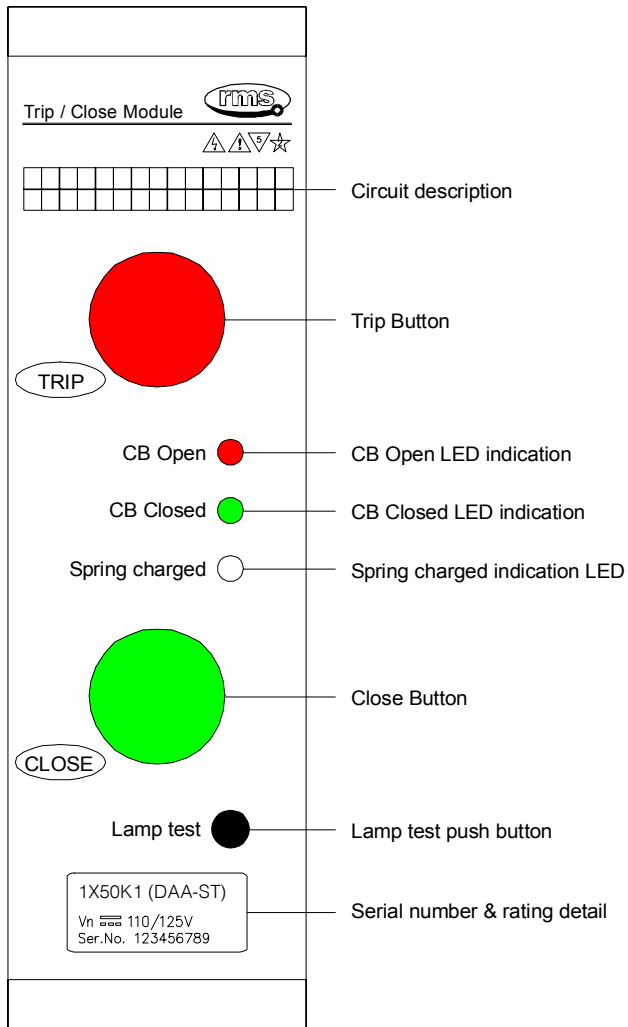

Figure 3:
1X50 Front Panel Layout

ORDER CODE

The order code determines the production build in the factory & cannot be changed in the field.

Generate the required order code as follows: e.g. 1X50-DAA-LST

General Type	Order Code			Options
1X50	1	2	3	4

1 SYSTEM VOLTAGE SELECTION

- A 24V DC
- B 32V DC
- C 48V DC
- D 110/125V DC (Standard)
- E 240/250V DC

2 BUTTON & LED COLOURS

- A Trip/Open RED / Close GREEN (Standard)
- B Trip/Open GREEN / Close RED

3 CUSTOM ENGRAVED CIRCUIT DESCRIPTION

- A Not required (Standard)
- B Required – Complete custom text details

4 OPTIONS

(Specify all option codes required)

- D Steering diodes
- L Locking cover
- S Spring charge status LED
- T Lamp test button

CUSTOM ENGRAVED CIRCUIT DESCRIPTION

The 1X50 front panel has provision for custom text to be engraved by the factory as per figure 3 if specified at time of order.

Complete the following table with one character per box. Submit completed labeling information with the 1X50 product ordering code. For maximum font size limit text to 1 line x 10 characters.

Text will be left justified.

Circuit Description

--	--	--	--	--	--	--	--	--	--	--

Australian Content

Unless otherwise stated the product(s) quoted are manufactured by RMS at our production facility in Melbourne Australia. Approximately 60% of our sales volume is derived from equipment manufactured in house with a local content close to 90%. Imported components such as semi-conductors are sourced from local suppliers & preference is given for reasonable stock holding to support our build requirements.

Quality Assurance

RMS holds NCSI (NATA Certification Services International), registration number 6869 for the certification of a quality assurance system to AS/NZS ISO9001-2008. Quality plans for all products involve 100% inspection and testing carried out before despatch. Further details on specific test plans, quality policy & procedures may be found in section A4 of the RMS product catalogue.

Product Packaging

Protection relays are supplied in secure individual packing cardboard boxes with moulded styrene inserts suitable for recycling. Each product & packing box is labeled with the product part number, customer name & order details.

Design References

The products & components produced by RMS are based on many years of field experience since Relays Pty Ltd was formed in 1955. A large population of equipment is in service throughout Australia, New Zealand, South Africa & South East Asia attesting to this fact. Specific product & customer reference sites may be provided on application.

Product Warranty

All utility grade protection & auxiliary relay products, unless otherwise stated, are warranted for a period of 24 months from shipment for materials & labour on a return to factory basis. Repair of products damaged through poor application or circumstances outside the product ratings will be carried out at the customer's expense.

Standard Conditions of Sale

Unless otherwise agreed RMS Standard Terms & Conditions (QF 907) shall apply to all sales. These are available on request or from our web site.



Relay Monitoring Systems Pty Ltd

6 Anzed Court, Mulgrave, Victoria 3170, AUSTRALIA

Tel: 61 3 9561 0266 Fax: 61 3 9561 0277 Email: rms@rmspl.com.au Web: www.rmspl.com.au