

Features

- High sensitivity (0.1% of I_n)
- 50Hz & HF noise suppression - tuned to 150 Hz
- Optional reset functions Instantaneous (Fast), definite time, count down
- 40-300V DC auxiliary supply Power supply fail relay drops out if the auxiliary supply fails.
- Optional 20-70V DC supply
- Low CT burden & high thermal rating
- Optional 1A or 5A CT input
- Instantaneous pick up LED
- Configurable output contacts
- 0-31s time delay (125ms steps)
- Push button / electrical flag reset
- Non-volatile trip indication
- Multi voltage inhibit / enable & flag reset inputs
- Size 2M draw out case

Application

If the bearing insulation on rotating machines breaks down, the voltage induced between the shaft ends, due to machine dissymmetries, creates a shaft current that can damage the bearings. The level of damage depends on the magnitude & duration of the shaft current. It is therefore desirable to provide sensitive protection that can detect shaft currents of 1A or less.

The shaft current measurement principle enables more sensitive protection than shaft voltage measurements or vibration monitoring. Vibration monitors only operate after bearing damage has occurred. By applying the shaft overcurrent protection relay type 2C139 together with a special current transformer, the machine can be tripped & the cause of the bearing insulation breakdown determined before the bearing is damaged.

Rejection of the 50Hz component is important where the shaft current transformer is exposed to large fundamental leakage flux from the machine. The 2C139 relay may be employed to overcome this problem by monitoring the 150Hz component.

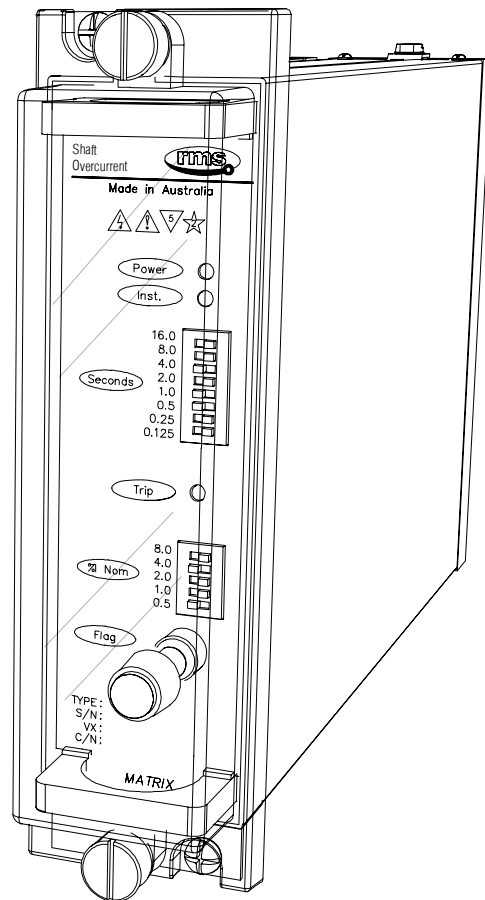

2C139 depicted in a 2M28 case

Operation

Made in Australia

The 2C139 protection relay measures the 150Hz component of shaft overcurrent & is available with a minimum setting sensitivity of 0.1% of I_n . Where the 50Hz fundamental frequency is to be monitored the 2C138 model should be specified.

Sensitive shaft overcurrent protection is provided with a high degree of accuracy over a wide range of input current settings & offers the high sensitivity & harmonic suppression required for this application. The 50Hz harmonic suppression feature combined with high frequency noise immunity minimizes the possibility of malfunction. An adjustable time delay is provided & an instantaneous output contact may be configured.

Current & time settings are fully adjustable using DIL switches readily accessible on the front panel of the relay & provide a high level of repeatability & accuracy. Visual indication of an output relay operation is provided by a non volatile LED indicator which may be hand or remotely reset.

A configurable status input is provided to ENABLE the operation of the 2C139 on application or removal of a control voltage.

The 2C139 may be configured with a number of different reset functions to provide instantaneous reset, definite time reset or induction disc reset emulation.

A switchmode power supply provides a very wide auxiliary operating range. A relay fail alarm is provided in the form of a C/O contact which is picked up when the auxiliary supply is healthy.

The 2C139 case is fitted with an automatic CT shorting switch to void an inadvertent open circuit when the relay module is removed from the case.

Time Delay Options

INSTANTANEOUS OPERATION

Due to the stiff harmonic filtering the minimum pick up time of the Shaft Overcurrent element is <75ms at 2x Is 150Hz.

Where output contact 3 is configured for instantaneous operation it will pick up when $I_s >$ the current pick up threshold irrespective of the front panel time delay setting.

Set configuration switch 3 to ON to enable instantaneous operation of output contact 3.

TIMER DELAY SETTING RANGE

0 to 31s in 125ms steps.

Output contacts 1 & 2 always operate in time delayed mode. Output contact 3 will also operate in time delayed mode provided configuration switch 3 is set to OFF.

TIME DELAY SETTING CHANGES

The time delay & function settings should only be changed when the timing initiate LED is extinguished. Time delay settings are read at the beginning of each timing sequence.

TIMING ACCURACY

Maximum timing error as a % of setting + uncertainty in ms.

Initiate input	AC Rejection Filter	
	ON	OFF
DC	-0.19% + 0.25ms	
AC	N/A	-0.19% + 19ms

Table 1

CONFIGURATION SWITCHES

Configuration switches are accessible to the user & can be set by withdrawing the relay module & following the instructions on the side plate label. A bank of 5 switches are provided as depicted below & are read each time the 2C139 is powered up:

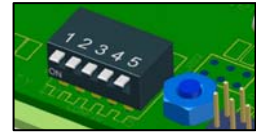
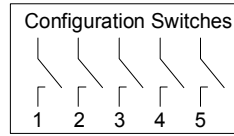

While the function of the configuration switches may vary for special custom models, the standard functions & default settings are described in the Ordering Information section.

SENSING INPUT RESET OPTIONS (Refer timing diagrams)

The reset characteristic is set using configuration switches 4 & 5.

Instantaneous

If the SEF element drops out before the pre set time delay is reached the timing element will reset in 20 to 50 ms at 10x Is.

Definite Time Reset (Treset)

With this reset option a definite reset time must be specified. If the SEF element drops out before the preset time delay is reached the delay timer will pause until the reset time has elapsed before resetting. If the SEF element picks up again before the reset time has elapsed, the delay timer will restart the timing sequence from the paused timing point.

Count Down Reset

If the SEF element drops out before the pre set time delay is reached, the timer will count down toward reset. If the SEF element picks up again before reset is reached the timer will start counting back up towards the time delay pre set.

RESET CHARACTERISTICS

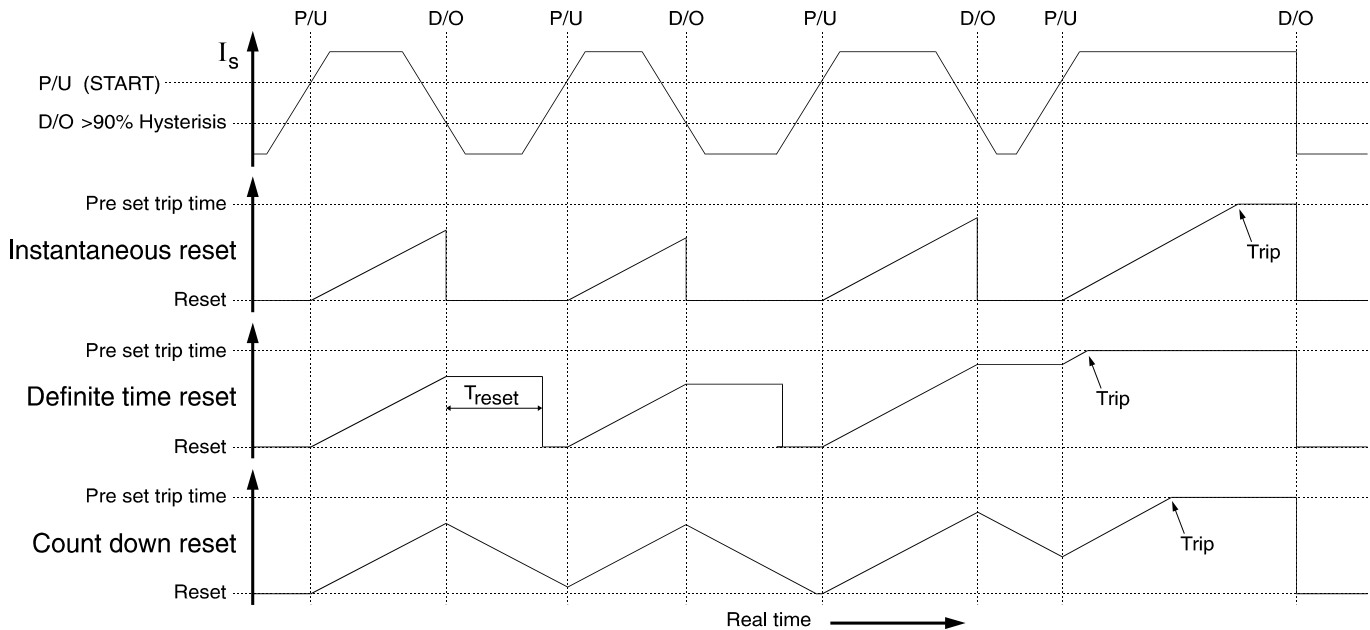

AUXILIARY SUPPLY

40-275V AC / 40-300V DC or 20-70V DC switchmode supply.

STATUS INPUT OPERATING VOLTAGE (AC rejection filter)

The operating range of the status inputs are set using internal configuration switch 1. This setting may be pre defined when ordering.

18 - 300V DC Set Configuration Switch to **ON**
In this mode the universal status input will reject AC signals that may be induced on the control wiring. Suitable for high security applications where a DC battery supply is available.

18 - 300V DC & 18 – 275V AC Set Configuration Switch to **OFF**
In this mode the universal status input is designed to operate on both AC & DC input voltages. Suitable for applications where an AC auxiliary voltage is available such as transformer or generator control panels.

STATUS INPUT MINIMUM OPERATING CURRENT

10mA P/U for 1ms then reducing to 1.5mA after 4ms.

While the function of the configuration switches may vary for special custom models, the standard functions & default settings are described in the Ordering Information section.

STATUS INPUT OPERATING TIME

Initiate input	Minimum	AC Rejection Filter	
		ON	OFF
DC	P/U	<16ms	<4ms
	D/O	<4ms	<16ms
AC	P/U	N/A	<23ms
	D/O		<33ms

Table 2

BURDENS

Auxiliary supply: (at 110V DC nominal supply)
Less than 5W independent of range with output relays picked up.

Sensing circuits: VA per phase all settings.

I amps	1A CT input	5A CT input
1	0.9	-
2	3.8	-
4	16	-
5	25	1.0
8	56	2.4
10	-	4.1
15	-	9.5
20	-	17
25	-	26

CT INPUT THERMAL WITHSTAND (Amps all settings)

	1A CT	5A CT
Continuous	2	10
4.5s	20	100
3s	35	180
2s	40	200
1s	60	300
0.5s	90	450

CT INPUT IMPEDANCE

1A CT: <1.2 ohms
5A CT: <0.1 ohms

AC CURRENT SETTING

Code C: 0.1% - 3.1% of 1A CT in 0.1% steps
Code D: 0.1% - 3.1% of 5A CT in 0.1% steps

DROPOUT PICKUP RATIO OF SEF ELEMENT

95% setting: PCB jumper J118 fitted left – Factory default
85% setting: PCB jumper J118 fitted right as per figure 1.

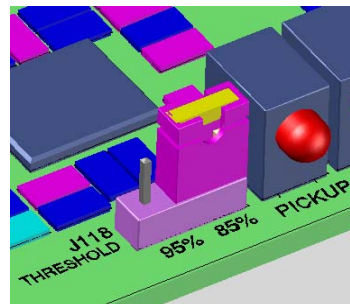

Figure 1:

To change the dropout / pickup ratio remove the relay module from the case, locate the three pin jumper header position J118 & fit jumper for 95% or 85% dropout pickup ratio.

CURRENT SETTING ACCURACY

+/-5% of setting +/-0.05% of nominal

HARMONIC REJECTION

50Hz: >30x setting
100Hz: >3x setting
150Hz: Tuned for 3rd harmonic detection
200Hz: >1.5 x setting
>300Hz: >2x setting

FRONT PANEL INDICATORS

Three LED indicators are provided on the front panel:

Power	On solid when auxiliary supply healthy	Green
Timing	Flashing during timing	Amber
Trip	On solid when output relay operated	Red

The trip LED status is stored in non volatile memory & will be restored when the 2C139 is powered up after loss of the auxiliary supply. The preserved trip LED state is reset using the front panel flag reset button or status input.

A hand & remote reset magnetic disc flag (permanent memory) indicator may be specified as an option. Note that an auxiliary supply is required to reset the flag circuits.

RELAY FAIL ALARM

A C/O alarm contact is maintained in the energized state when all of the following conditions are met:

- The auxiliary supply is applied
- The internal 24V DC rail is within acceptable limits
- The CPU hardware watchdog maintains a pulsing output

A CPU software watchdog records "suspect" events to an assert register and if necessary performs a soft restart.

OUTPUT RELAY CONTACT CONFIGURATION

2 N/O time delayed contacts
1 N/O time delayed or instantaneous contact

OUTPUT CONTACT DWELL TIME

Once operated all time delayed output contacts have a minimum dwell time of 100ms.

REMOTE FLAG RESET INPUT

Application of a control voltage to the optional remote flag reset input will cause the bistable flag to be reset.

Technical Data

OUTPUT CONTACT RATINGS

IEC60255-0-2

Carry continuously	5A AC or DC
Make & carry	0.5s 20A AC or DC
L/R $\leq 40\text{ms}$ & $V \leq 300\text{V}$	0.2s 30A AC or DC
	AC resistive 1,250VA
Break capacity	AC inductive 250VA @ PF ≤ 0.4
$I \leq 5\text{A}$ & $V \leq 300\text{V}$	DC resistive 75W
	DC inductive 30W @ L/R $\leq 40\text{ms}$
	50W @ L/R $\leq 10\text{ms}$
	10° at maximum load
Minimum number of operations	
Minimum recommended load	0.5W limit 10mA / 5V

TRANSIENT OVERVOLTAGE

IEC60255-5 CLASS III

Between all terminals & earth	5kV 1.2/50us 0.5J
Between independent circuits without damage or flashover	5kV 1.2/50us 0.5J

INSULATION COORDINATION

IEC60255-5 CLASS III

Between all terminals & earth	2.0kV RMS for 1 minute
Between independent circuits	2.0kV RMS for 1 minute
Across normally open contacts	1.0kV RMS for 1 minute

AUXILIARY SUPPLY

IEC60255-11

Allowable breaks / dips in supply	$\leq 20\text{ms}$
Collapse to zero from nominal voltage	

HIGH FREQUENCY DISTURBANCE

IEC60255-22-1 CLASS III

2.5kV 1MHz common mode	$\leq 3\%$ variation
1.0kV 1MHz differential mode	

ELECTROSTATIC DISCHARGE

IEC60255-22-2 CLASS III

6kV contact discharge	$\leq 5\%$ variation
-----------------------	----------------------

RADIO FREQUENCY INTERFERENCE

IEC60255-22-3

10V/m, 80 TO 1,000MHz	$\leq 5\%$ variation
-----------------------	----------------------

FAST TRANSIENT

IEC60255-22-4

4kV, 5/50ns, 100KHz repetitive	$\leq 3\%$ variation
--------------------------------	----------------------

CONDUCTED RFI

IEC60255-22-6

10V, 0.15 to 80MHz	$\leq 5\%$ variation
--------------------	----------------------

TEMPERATURE RANGE

Operating:	-5 to +55°C
Storage:	-25 to +75°C

HUMIDITY

IEC68-2-1/2

40 °C & 95% RH non condensing	
-------------------------------	--

CASE

Size 2M28-S draw out
28 M4 screw terminals
Flush panel mount or 4U high 1/8 width 19 inch rack mount

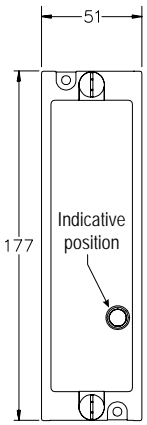
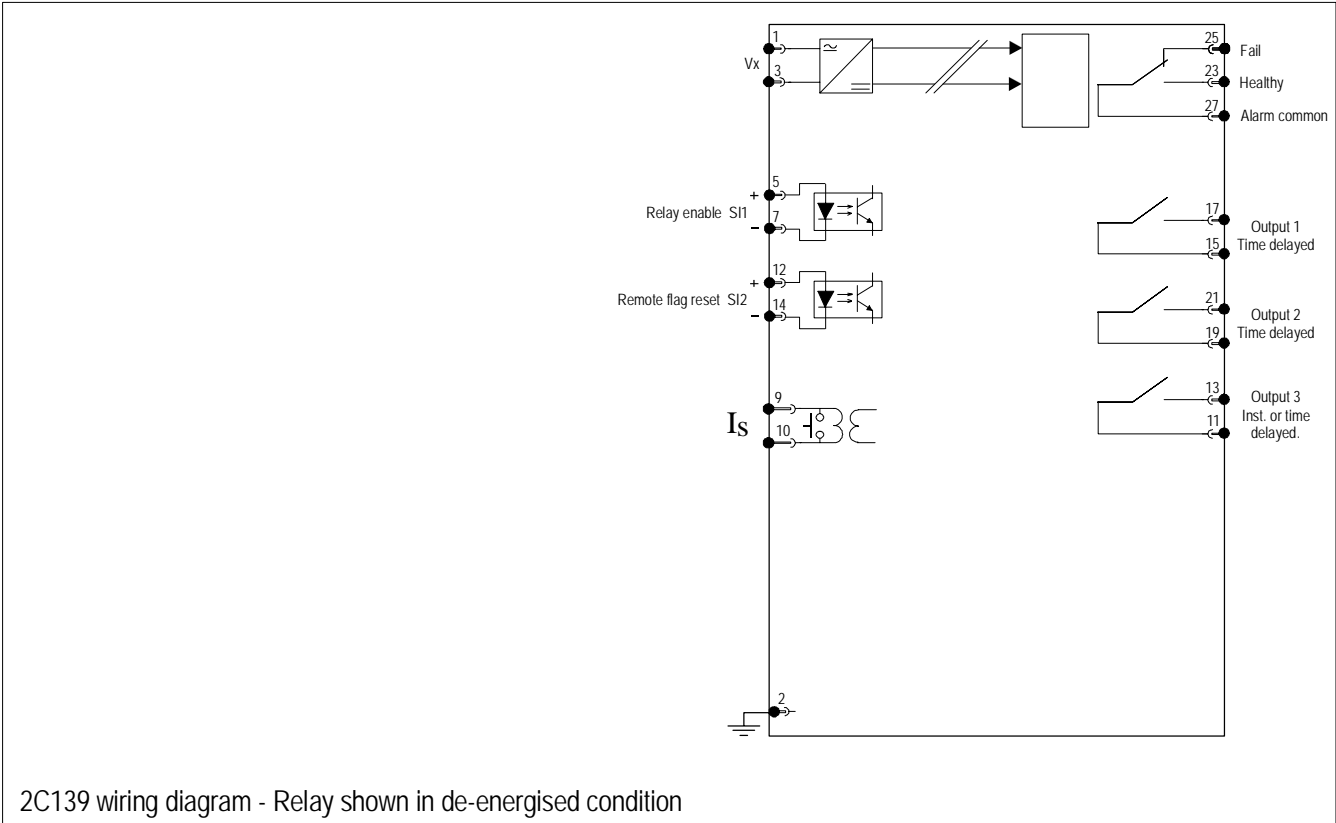

Front view

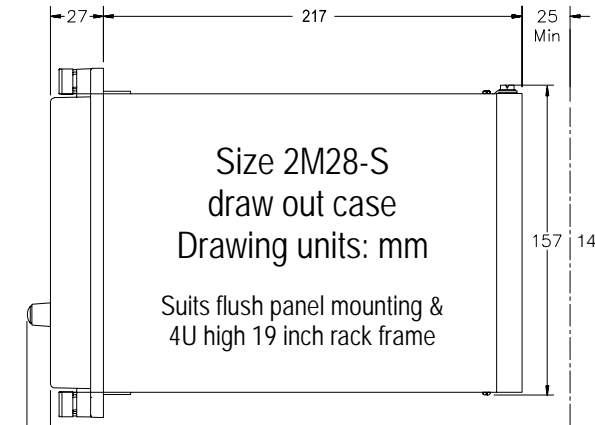

Side view

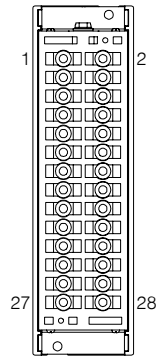

Terminal layout

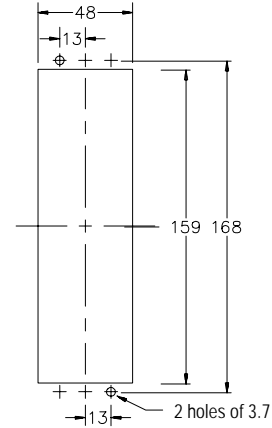

Panel cut out

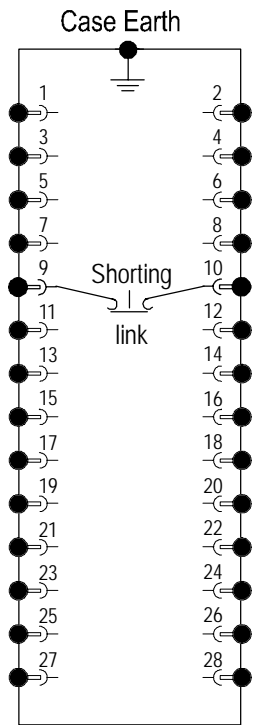

2M28 Case terminations (REAR VIEW)

Ordering Information

ORDER CODE

The order code determines the production build in the factory & cannot be changed in the field.

Generate the required order code as follows: e.g. 2C139-BCA

General Type	Order Code		
	1	2	3
2C139			

1 AUXILIARY SUPPLY RANGE

- A 20-70V DC
- B 40-275V AC & 40-300V DC

2 CT INPUT RATING

- C 1A
- D 5A

3 TRIP FLAG

- A Red LED non volatile trip indication (Standard)
- B Magnetic disc trip flag

CONFIGURATION CODE (Optional specification)

The configuration code can be set in the field by withdrawing the relay module & following the instructions on the side plate label.

The configuration code may be specified at time of order so that the relay will be shipped from the factory pre-set to meet customer requirements. e.g. CONFIG-01011

If a configuration code is not specified the factory default will be set as indicated below. i.e. CONFIG-11111

Specify factory Configuration	Configuration Switches				
	1	2	3	4	5
CONFIG					

1 STATUS INPUT OPERATION

- 1 ON DC operation only - AC rejection ON (Default)
- 0 OFF AC / DC operation - AC rejection OFF

2 RELAY ENABLE INPUT

- 1 ON Apply volts to enable (Default)
- 0 OFF Remove volts to enable

3 OUTPUT RELAY FUNCTION

- 1 ON Output contact 3 operates instantaneously when $I_s >$ current pick up threshold irrespective of the front panel time delay settings (Default)
- 0 OFF All outputs contacts are time delayed

4 RESET TIME FUNCTION

- 1 ON Instantaneous reset characteristic (Default)
- 0 OFF Time delayed reset characteristic

5 TIME DELAYED RESET CHARACTERISTIC

- 1 ON 10s definite time reset * (Default)
- 0 OFF Count down reset

Note: * Consult factory for other definite time reset delays.

Australian Content

Unless otherwise stated the product(s) quoted are manufactured by RMS at our production facility in Melbourne Australia. Approximately 60% of our sales volume is derived from equipment manufactured in house with a local content close to 90%. Imported components such as semi-conductors are sourced from local suppliers & preference is given for reasonable stock holding to support our build requirements.

Quality Assurance

RMS holds NCSI (NATA Certification Services International), registration number 6869 for the certification of a quality assurance system to AS/NZS ISO9001-2000. Quality plans for all products involve 100% inspection and testing carried out before despatch. Further details on specific test plans, quality policy & procedures may be found in section A4 of the RMS product catalogue.

Product Packaging

Protection relays are supplied in secure individual packing cardboard boxes with moulded styrene inserts suitable for recycling. Each product & packing box is labeled with the product part number, customer name & order details.

Design References

The products & components produced by RMS are based on many years of field experience since Relays Pty Ltd was formed in 1955. A large population of equipment is in service throughout Australia, New Zealand, South Africa & South East Asia attesting to this fact. Specific product & customer reference sites may be provided on application.

Product Warranty

All utility grade protection & auxiliary relay products, unless otherwise stated, are warranted for a period of 24 months from shipment for materials & labour on a return to factory basis. Repair of products damaged through poor application or circumstances outside the product ratings will be carried out at the customer's expense.

Standard Conditions of Sale

Unless otherwise agreed RMS Standard Terms & Conditions (QF 907) shall apply to all sales. These are available on request or from our web site.



Relay Monitoring Systems Pty Ltd

6 Anzed Court, Mulgrave, Victoria 3170, AUSTRALIA

Tel: 61 3 9561 0266 Fax: 61 3 9561 0277 Email: rms@rmspl.com.au Web: www.rmspl.com.au