

Current Check Relay

Features

- 10:1 PU setting ranges
Select from two options:
- 5-50% or 20-200% of nominal input current
- 1A or 5A nominal CT's
- Fast O/C pick up time <15ms
- Fast O/C reset time <15ms
- <5% transient over-reach
- Phase segregated initiate input
- 3 phase initiate input
- Internal timer initiate input
- Non volatile trip flag
- Remote flag reset input
- Current pick up LED per phase
- 8 C/O output contacts
- Three time delay ranges
0-0.99s, 0-9.9s, 0-99s
- High accuracy & repeatability –
timing compensated for output
relay delay
- Time settings easily selected
by digital thumb wheel switches
- Timing in progress LED
- 40-300V DC auxiliary supply
Power supply fail relay drops
out if the auxiliary supply fails.
- Optional 20-70V DC supply
- Size 4M draw out case

Application

The 2C65 Series relays are adjustable AC current sensing relays designed for high or low voltage power systems where they can be used in a large number of overcurrent applications.

Definite time overcurrent relays offer advantages over inverse time protection in power systems which have a wide variation in source impedance. Faults can be cleared in relatively short times irrespective of the magnitude of the fault current, & coordination of several relays in a system can be obtained at all times regardless of fault current variation.

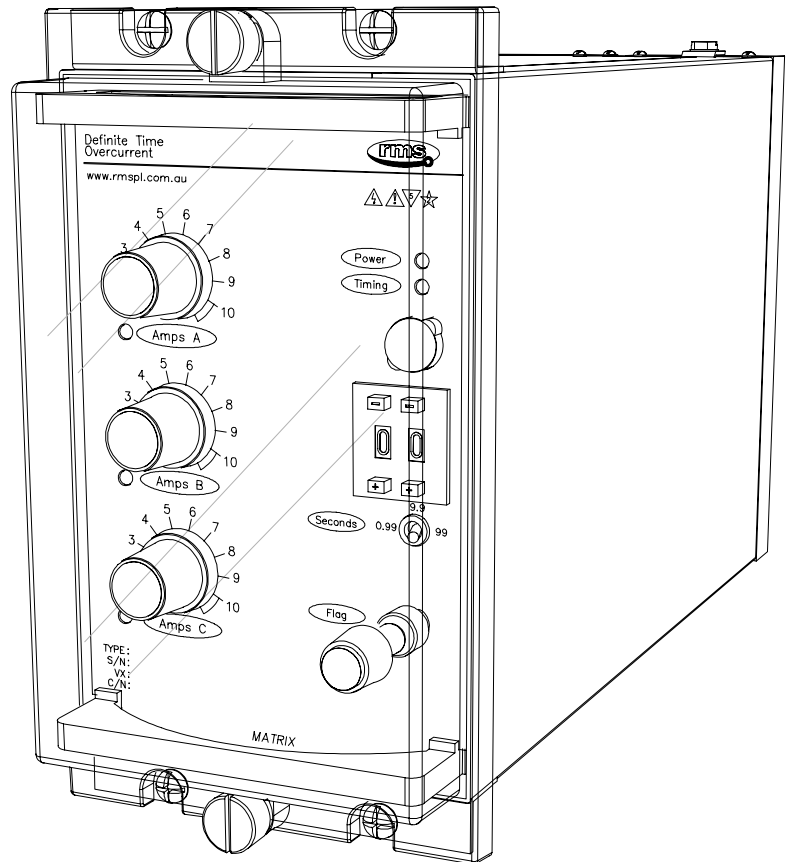

2C65 in a 4M56 case

Operation

Made in Australia

The 2C65 Series relay is a three pole current detector with independently adjustable sensing circuits driving a common adjustable digital setting timing element.

Five (5) status inputs & eight (8) relay outputs are provided as standard to allow the 2C65 to be operated in a number of different configurations:

- ◆ Time delayed or instantaneous output contacts;
- ◆ Phase segregated or 3 phase output contacts;
- ◆ Single phase or 3 phase current initiation inputs;
- ◆ Timer initiate input logic;

After pick up & time out the latching target indicator (LED or magnetic flag), is set. The flag may be reset at the front panel or remotely reset via a status input.

Fully solid state sensing & measuring circuitry is employed with each phase current setting continuously adjustable on a front panel control. Air core CT's are employed to provide a very fast reset characteristic.

The wide range switchmode power supply, input current transformer, output relays & status inputs form the essential barriers against high voltage line transients.

Instantaneous Operation Version

The 2C65 may be specified without the integrated delay timer for instantaneous current check function.

Zero Stand by Burden Relay

The 2C80 current check relay may be specified where a zero stand by burden is required. Initiation of the relay is achieved through application of the auxiliary supply on a single or three phase basis. The linear power supply provides high speed start up but results in higher operating burden & non continuous rating. The 2C80 may be specified with or without an integrated time delay element.

OPERATING LOGIC CONFIGURATION

The 2C65 may be configured & wired to operate in phase segregated & three phase modes as depicted in logic diagram figures 1 to 4. Where the 2C65 is specified without the integrated time delay element all output contacts operate as instantaneous & the Timer Initiate input does not function.

In each logic example output contacts 1-4 have been set for instantaneous operation - Configuration switch 5 set to ON.

Where configuration switch 5 is set to OFF output contacts 1-4 will operate as time delayed contacts.

For figures 1 to 4 the operating logic is repeated for phase B & C.

TIMER INITIATE INPUT

CB auxiliary contact or palette switch check scheme

This form of circuit breaker failure protection is typically applied to transformer protection to provide supplementary coverage for faults that are low in current magnitude that would otherwise not be protected by a current check circuit breaker failure protection scheme. For example, Buchholz (gas) protection & reflected faults through transformers.

It should be noted that initiating the timer via the timer initiate status input will cause all delayed output contacts to pick up once the preset time delay has expired. In all circumstances the timer initiate status input must be reset before any time delayed contacts are reset.

Operating Logic

PHASE SEGREGATED OPERATING LOGIC

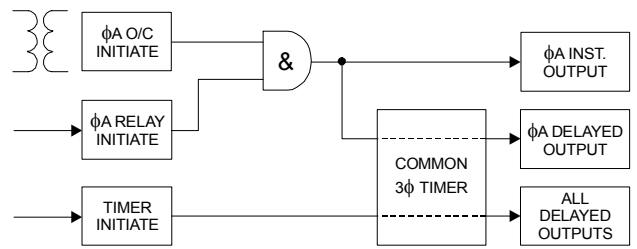

Figure 1:
Phase segregated inputs & phase segregated output contacts
Configuration switch 4 set to OFF
Configuration switch 5 set to ON

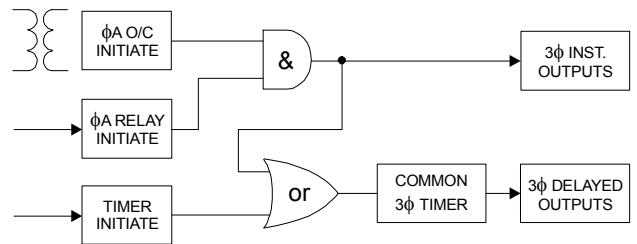

Figure 2:
Phase segregated inputs & 3 phase output contacts
Configuration switch 4 set to ON
Configuration switch 5 set to ON

THREE PHASE OPERATING LOGIC

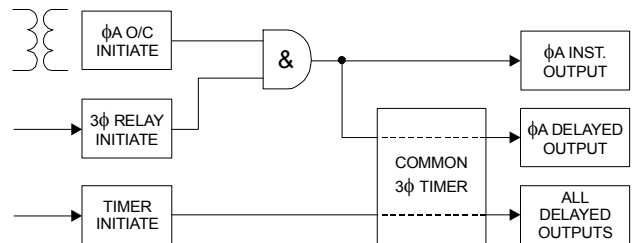

Figure 3:
Three phase input & phase segregated output contacts
Configuration switch 4 set to OFF
Configuration switch 5 set to ON

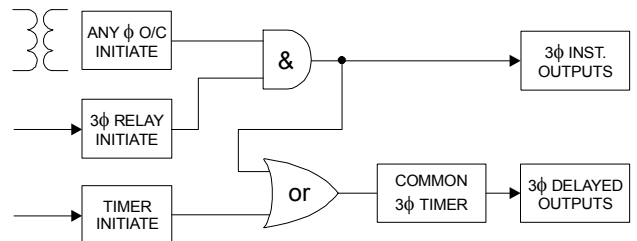
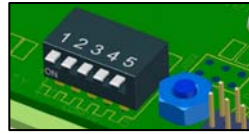
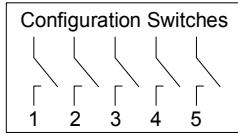

Figure 4:
Three phase input & 3 phase output contacts
Configuration switch 4 set to ON
Configuration switch 5 set to ON

CONFIGURATION SWITCHES

Configuration switches are accessible to the user & can be set by withdrawing the relay module & following the instructions on the side plate label. A bank of 5 switches are provided as depicted below & are read each time the 2C65 is powered up:



While the function of the configuration switches may vary for special custom models, the standard functions & default settings are described below:

Switch 1 - Status input operation

ON DC operation only - AC rejection ON (Default)
 OFF AC / DC operation - AC rejection OFF

Switch 2 - Current initiate inputs

ON Apply volts to enable (Default)
 OFF Remove volts to enable

Switch 3 - Timer initiate input

ON Apply volts to enable (Default)
 OFF Remove volts to enable

Switch 4 - Output relay function

ON Three phase outputs (Default)
 OFF Phase segregated outputs

Switch 5 - Output relay timing function

ON Output relays 1-4 instantaneous (Default)
 OFF Output relays 1-4 time delayed

FRONT PANEL INDICATORS

LED indicators are provided on the front panel:

Power	On solid when auxiliary supply healthy	Green
Current	On when phase current picked up	Red x 3
Timing	Flashing during timing	Amber
Trip	Latches on when trip relay operates	Red

The trip LED status is stored in non volatile memory & is restored when the 2C65 is powered up after loss of the auxiliary supply. The preserved trip LED state is reset using the front panel flag reset button or status input.

A hand & remote reset magnetic disc flag (permanent memory) trip indicator may be specified as an option. Note that an auxiliary supply is required to reset the flag circuits.

CURRENT SETTINGS

5-50% or 20-200% of nominal CT rating
 Repeatability: $\pm 2\%$ of setting
 Setting: $\pm 5\%$ of maximum setting

DROPOUT PICKUP RATIO

85% setting: PCB jumper J103 fitted left – Factory default
 75% setting: PCB jumper J103 fitted right as per figure 5.

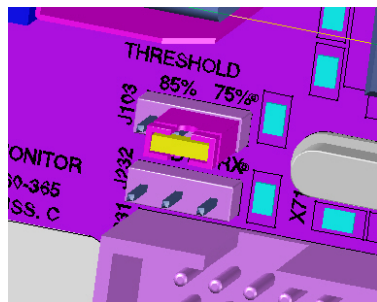

Figure 5:

To change the dropout / pickup ration remove the relay module from the case, locate the three pin jumper header position J103 & fit jumper for 75% or 85% dropout pickup ratio.

Configuration & Setting

OPERATING TIME OF CURRENT ELEMENT

At 2 X O/C setting: Logic pick up time <10ms

Time delayed contact reset

Logic drop out time is less than 15ms when the current drops from 2 X O/C setting to zero. This means that if current is removed >15ms before the preset time delay expires the trip output contacts will not operate.

Instantaneous contact reset

Output contacts set for instantaneous operation will reset in less than 15ms when current drops from 2 X O/C setting to zero.

OUTPUT CONTACT DWELL TIME

Once operated all time delayed output contacts have a minimum dwell time of 100ms to allow adequate time for CB pallet switches to operate.

TIME SETTING RANGES

The 2C65 relay allows for precision time settings of between zero (Minimum operate time) & 99 seconds. This is achieved by the use of two decimal thumb wheel switches & a range multiplication switch on the front panel.

Range Selector Setting	Achievable Time Setting Range	Resolution of Time Setting
Range 1	Zero to 0.99 Sec	0.01 Sec
Range 2	Zero to 9.9 Sec	0.1 Sec
Range 3	Zero to 99 Sec	1 Sec

Table 1

TIME SETTING CHANGES

The time delay & function settings should only be changed when the timing initiate LED is extinguished. Time settings are read at the beginning of each timing sequence.

TIMER INITIATE STATUS INPUT DELAY

Initiate input	Minimum	AC Rejection Filter	
		ON	OFF
DC	P/U	<16ms	<4ms
	D/O	<4ms	<16ms
AC	P/U	N/A	<23ms
	D/O		<33ms

Table 2

MINIMUM OUTPUT CONTACT PICK UP TIME

For an output contact to pick up, both the O/C & relay initiate logic conditions must be met as per figures 1 to 4. The minimum pick up time of a contact is therefore determined by the last logic element to pick up.

Where a status input initiate is the last element to pick up the minimum contact pick up time is equal to the status input delays in Table 2 + 6ms.

Where an O/C initiate is the last element to pick up the minimum contact pick up time is less than 15ms.

Time delay settings \leq to the above minimums will result in a relay contact operate time equal to the minimum as per figure 6.

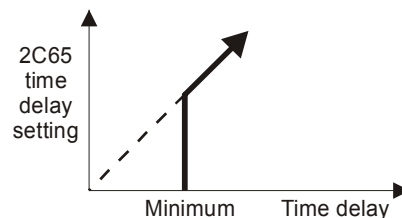

Figure 6

TIMING ACCURACY

Maximum timing error as a % of setting + uncertainty in ms.

Initiate input	AC Rejection Filter	
	ON	OFF
DC	-0.19% + 0.25ms	
AC	N/A	-0.19% + 19ms

Table 3

BURDENS

Auxiliary supply: (at 110V DC nominal supply)
 Less than 3 watts during timing.
 Less than 6 watts with output relays energized.

Sensing circuits: VA per phase all settings at 50Hz.

I amps	1A CT input	5A CT input
1	0.25	<0.01
5	6.3	0.18
10	25	0.72
20	100	2.9
25	-	4.5
30	-	6.5

CT INPUT THERMAL WITHSTAND (Per phase)

	1A CT	5A CT *
Continuous	3.5	25
4.5s	39	250
3s	75	450
2s	90	550
1s	120	800
0.5s	180	1,000

* M Series case terminals are limited to 400A for 1s.

AUXILIARY SUPPLY

40 – 275V AC & 40-300V DC switchmode supply with power on LED
 20 – 70V DC switchmode supply with power on LED.

REMOTE FLAG RESET FUNCTION

Application of a control voltage to the optional remote flag reset input will cause the bistable flag to be reset.

STATUS INPUT OPERATING VOLTAGE (AC rejection filter)

The operating range of the status inputs are set using internal configuration switch 1. This setting may be pre defined when ordering.

18 - 300V DC Set Configuration Switch to **ON**
 In this mode the universal status input will reject AC signals that may be induced on the control wiring. Suitable for high security applications where a DC battery supply is available.

18 - 300V DC & 18 – 275V AC Set Configuration Switch to **OFF**
 In this mode the universal status input is designed to operate on both AC & DC input voltages. Suitable for applications where an AC auxiliary voltage is available such as transformer or generator control panels.

STATUS INPUT MINIMUM OPERATING CURRENT

10mA P/U for 1ms then reducing to 1.5mA after 4ms.

While the function of the configuration switches may vary for special custom models, the standard functions & default settings are described in the Ordering Information section.

OUTPUT CONTACTS

Eight (8) C/O self reset contacts.
 Function as described in the wiring diagram.

RELAY FAIL ALARM

A C/O alarm contact is maintained in the energized state when all of the following conditions are met:

- The auxiliary supply is applied
- The internal 24V DC rail is within acceptable limits
- The CPU hardware watchdog maintains a pulsing output

A CPU software watchdog records "suspect" events to an assert register and if necessary performs a soft restart.

OUTPUT CONTACT RATINGS

IEC60255-0-2

Carry continuously	5A AC or DC
Make & carry	0.5s 20A AC or DC
L/R ≤ 40ms & V ≤ 300V	0.2s 30A AC or DC
	AC resistive 1,250VA
Break capacity	AC inductive 250VA @ PF ≤ 0.4
I ≤ 5A & V ≤ 300V	DC resistive 75W
	DC inductive 30W @ L/R ≤ 40ms
	50W @ L/R ≤ 10ms
Minimum number of operations	10 ⁶ at maximum load
Minimum recommended load	0.5W limit 10mA / 5V

TRANSIENT OVERVOLTAGE

IEC60255-5 CLASS III

Between all terminals & earth 5kV 1.2/50us 0.5J
 Between independent circuits without damage or flashover 5kV 1.2/50us 0.5J

INSULATION COORDINATION

IEC60255-5 CLASS III

Between all terminals & earth 2.0kV RMS for 1 minute
 Between independent circuits 2.0kV RMS for 1 minute
 Across normally open contacts 1.0kV RMS for 1 minute

AUXILIARY SUPPLY

IEC60255-11

Allowable breaks / dips in supply ≤ 20ms
 Collapse to zero from nominal voltage

HIGH FREQUENCY DISTURBANCE

IEC60255-22-1 CLASS III

2.5kV 1MHz common mode ≤ 5% variation
 1.0kV 1MHz differential mode

ELECTROSTATIC DISCHARGE

IEC60255-22-2 CLASS III

6kV contact discharge ≤ 5% variation

RADIO FREQUENCY INTERFERENCE

IEC60255-22-3

10V/m, 80 TO 1,000MHz ≤ 5% variation

FAST TRANSIENT

IEC60255-22-4

4kV, 5/50ns, 100KHz repetitive ≤ 5% variation

CONDUCTED RFI

IEC60255-22-6

10V, 0.15 to 80MHz ≤ 5% variation

TEMPERATURE RANGE

IEC68-2-1/2

Operating: -5 to +55°C
 Storage: -25 to +75°C

HUMIDITY

IEC68-2-78

40°C & 95% RH non condensing

CASE

Size 4M56-S draw out
 56 M4 screw terminals
 Flush panel mount or 4U high 1/4 width 19 inch rack mount

SHIPPING DETAILS

Each relay is supplied individually packed in pre formed cardboard cartons with internal moulded polystyrene former.

Weight: 3.3Kg
 Size: 370(L) x 240(W) x 145(D)mm - Size 4 case

ACCESSORIES SUPPLIED WITH EACH RELAY

1 x M4 self threading mounting screw kit P/N 290-406-151
 2 x M4 terminal screw kit (28 per kit) P/N 290-407-153

Output Relay Configuration		
	Configuration switch 4 set to OFF	Configuration switch 4 set to ON
1	φA Inst/Timed	3φ Inst/Timed
2	φB Inst/Timed	3φ Inst/Timed
3	φC Inst/Timed	3φ Inst/Timed
4	3φ Inst/Timed	3φ Inst/Timed
5	φA Timed	3φ Timed
6	φB Timed	3φ Timed
7	φC Timed	3φ Timed
8	3φ Timed	3φ Timed

Time delay outputs only available with timer option
Relays 1-4 are marked 'Inst/Timed' as the timing function is controlled by the position of configuration switch 5.
ON = Instantaneous
OFF = Time delayed

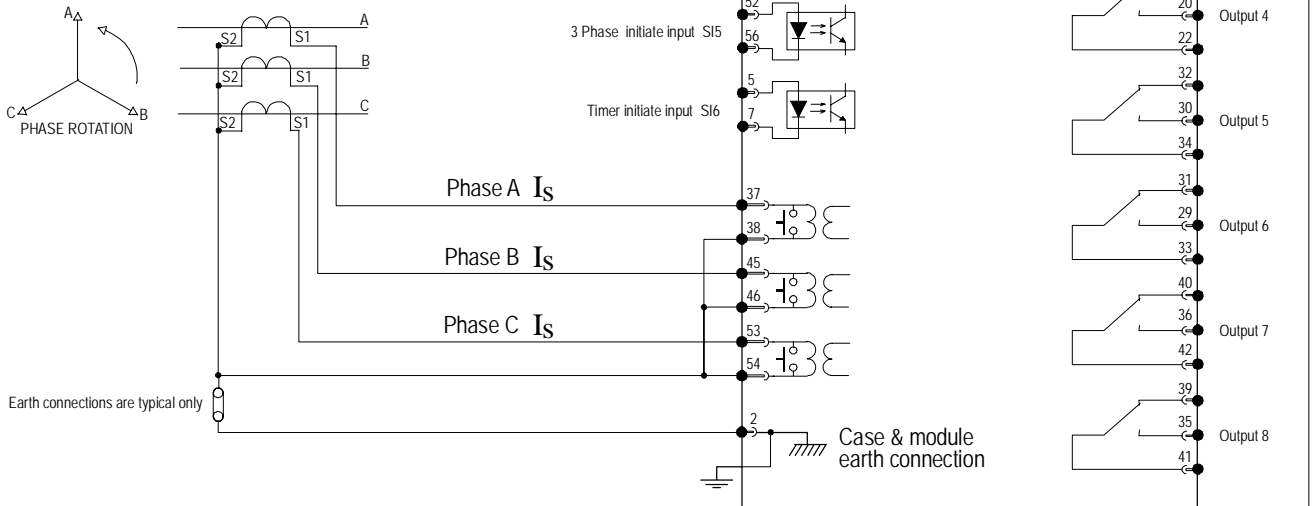
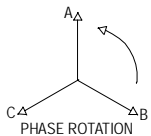

2C65 wiring diagram

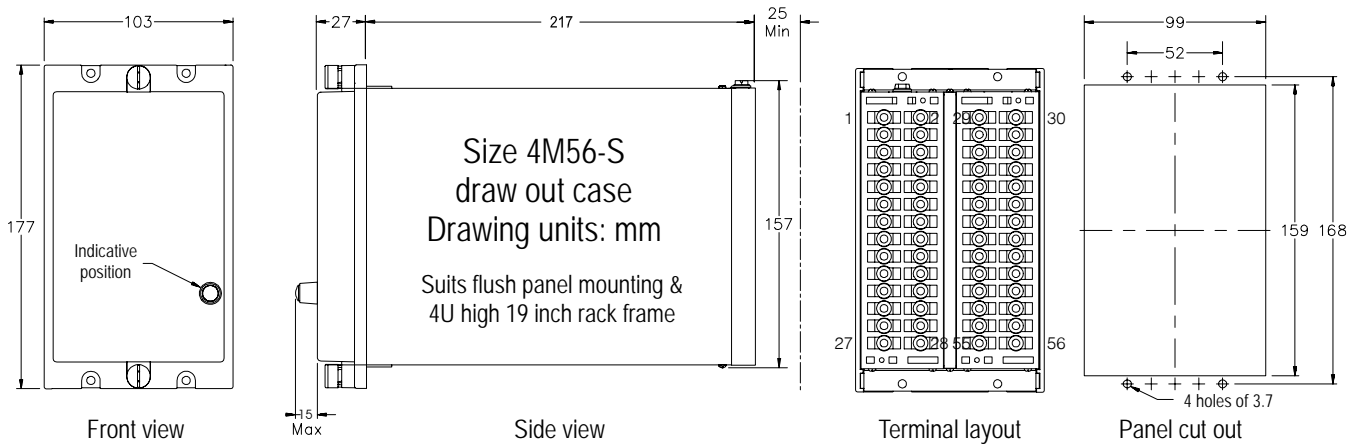

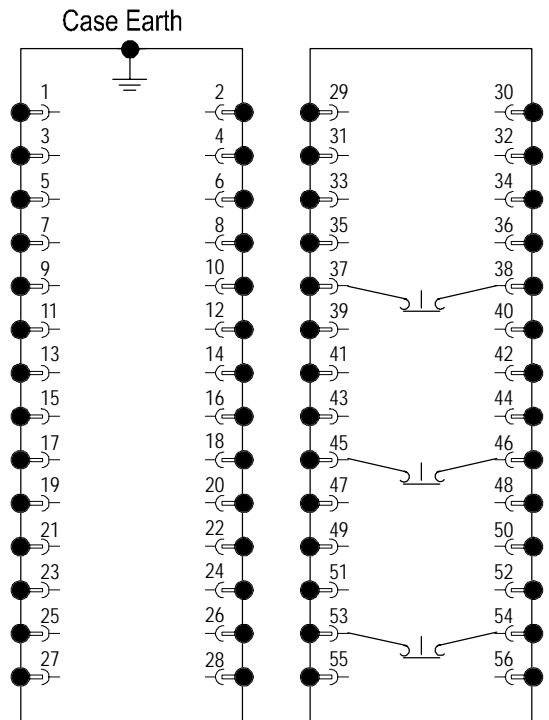

4M56 Case terminations (REAR VIEW)

Ordering Information

ORDER CODE

The order code determines the production build in the factory & cannot be changed in the field.

Generate the required order code as follows: e.g. 2C65-BBAB

General Type	Order Code			
2C65	1	2	3	4

1 AUXILIARY SUPPLY RANGE

- A 20-70V DC
- B 40-275V AC & 40-300V DC

2 CURRENT SETTING (% of nominal)

- A 5-50% All phases
- B 20-200% All phases
- C 20-200% Phase A & C + 5-50% E/F (In place of phase B)

3 CT RATING (Nominal)

- A 1A
- B 5A

4 TIMING FUNCTION

- A No time delay setting - Instantaneous overcurrent
- B Definite time delay - LED trip indication (Standard)
- C Definite time delay - Magnetic disc trip flag

CONFIGURATION CODE

(Optional specification)

The configuration code can be set in the field by withdrawing the relay module & following the instructions on the side plate label.

The configuration code may be specified at time of order so that the relay will be shipped from the factory pre-set to meet customer requirements. e.g. CONFIG-01011

If a configuration code is not specified the factory default will be set as indicated below. i.e. CONFIG-11111

Specify factory Configuration	Configuration Switches				
CONFIG	1	2	3	4	5

1 STATUS INPUT OPERATION

- 1 ON DC operation only - AC rejection ON (Default)
- 0 OFF AC / DC operation - AC rejection OFF

2 CURRENT INITIATE INPUTS

- 1 ON Apply volts to enable (Default)
- 0 OFF Remove volts to enable

3 TIMER INITIATE INPUT

- 1 ON Apply volts to enable (Default)
- 0 OFF Remove volts to enable

4 OUTPUT RELAY FUNCTION

- 1 ON Three phase outputs (Default)
- 0 OFF Phase segregated outputs

5 OUTPUT RELAY TIMING FUNCTION - Where timer fitted

- 1 ON Output relays 1-4 instantaneous (Default)
- 0 OFF Output relays 1-4 time delayed

Australian Content

Unless otherwise stated the product(s) quoted are manufactured by RMS at our production facility in Melbourne Australia. Approximately 60% of our sales volume is derived from equipment manufactured in house with a local content close to 90%. Imported components such as semi-conductors are sourced from local suppliers & preference is given for reasonable stock holding to support our build requirements.

Quality Assurance

RMS holds NCSI (NATA Certification Services International), registration number 6869 for the certification of a quality assurance system to AS/NZS ISO9001-2000. Quality plans for all products involve 100% inspection and testing carried out before despatch. Further details on specific test plans, quality policy & procedures may be found in section A4 of the RMS product catalogue.

Product Packaging

Protection relays are supplied in secure individual packing cardboard boxes with moulded styrene inserts suitable for recycling. Each product & packing box is labeled with the product part number, customer name & order details.

Design References

The products & components produced by RMS are based on many years of field experience since Relays Pty Ltd was formed in 1955. A large population of equipment is in service throughout Australia, New Zealand, South Africa & South East Asia attesting to this fact. Specific product & customer reference sites may be provided on application.

Product Warranty

All utility grade protection & auxiliary relay products, unless otherwise stated, are warranted for a period of 24 months from shipment for materials & labour on a return to factory basis. Repair of products damaged through poor application or circumstances outside the product ratings will be carried out at the customer's expense.

Standard Conditions of Sale

Unless otherwise agreed RMS Standard Terms & Conditions (QF 907) shall apply to all sales. These are available on request or from our web site.



Relay Monitoring Systems Pty Ltd

6 Anzed Court, Mulgrave, Victoria 3170, AUSTRALIA

Tel: 61 3 9561 0266 Fax: 61 3 9561 0277 Email: rms@rmspl.com.au Web: www.rmspl.com.au