

Features

- Crystal frequency reference
- 15.00 to 22.5ms setting range
- 0.01ms digital period setting resolution
- Digital time delay setting
- Undervoltage lockout function
- Remote flag reset
- Low burden
- Hand reset magnetic disc flag
- Wide range of case options
- Size 4M draw out case
- Made in Australia

Application

The 2H33 frequency relay is suitable for use in load shedding applications where accurate measurement of system frequency is necessary to ensure the minimum inconvenience to consumers.

Where multiple level of frequency load shedding is required it is advisable to use the 2H34 four stage frequency relay plus a single 2H33 as a check stage.

This relay is available in a range of configurations & case styles. Where multiple levels of load shedding are required up to four modules may be fitted in a single 4U high rack frame. Each module is a stand alone device with its own power supply, detection circuitry & output relay giving increased system reliability. A 24V DC input option is available for remote reset of the relay flags.

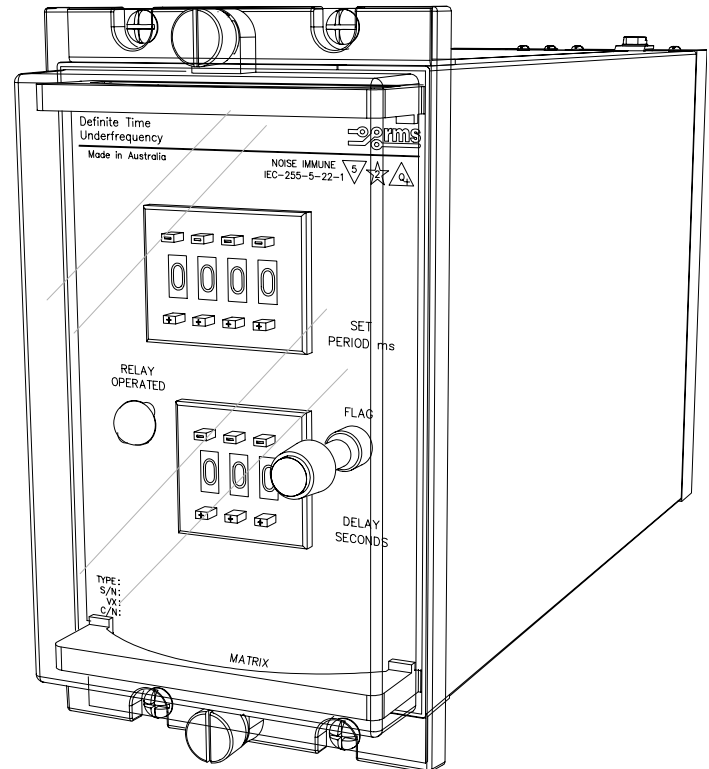

2H33 depicted in a 4M28 case

Operation

Made in Australia

The 2H33 Digital Under Frequency Relay is a single phase, solid state device which provides detection of under frequency conditions with definite time delay & undervoltage lockout function. Setting of both the frequency level & time delay is made using thumbwheel switches mounted on the front panel.

High accuracy is achieved by the crystal locked circuit design, whilst an active bandpass filter on the input provides rejection of harmonics.

FREQUENCY SENSING CIRCUITRY CHARACTERISTICS

Setting Range 15.00 to 22.50 ms period
(ie. 66.67 to 44.44 Hertz)
Thumbwheel switch selection with 0.01 ms resolution

Accuracy $\pm 0.05\%$ of setting

Repeatability $\pm 0.01\text{ms}$

Hysteresis Less than 0.05 ms

Response Time 100ms(approx.) Dependent on input frequency & degree & rate of frequency shift

Sensing Supply 110V AC nominal (140V AC max. continuous)

Sensing Burden Less than 2VA at nominal

U/voltage Lockout Preset at 50% of nominal.
(May be internally adjusted within the range 30% to 60% of nominal).

TIMER CIRCUITRY CHARACTERISTICS

Setting Range 0.05 to 9.99 Sec.
Thumbwheel switch selection with 0.01 Sec. resolution. Caution should be exercised when setting below 0.05 Sec. as instability may occur under certain conditions.

Accuracy $\pm 1\%$ of setting, + 20 ms -0 ms

Repeatability Less than 0.01 sec

Reset Time Internal DIL Switch selection of from 1 to 9 "good" input cycles to elapse before timer resets

AUXILIARY SUPPLY BURDEN

10W maximum (110V version)

STANDARD OUTPUT CONTACTS (Idec RH PCB mounting type)

Maximum Contact Capacity (Amps)

Voltage	DC			AC		
	30	125	250	110	220	250
Resistive	10	2.4	1.2	10	7	6.6
Inductive L/R 7ms	7.5	1.8	0.9	7.5	5	4.4

Make & Carry for 200ms

30A at 250V DC resistive

Maximum Break Capacity

0.34A at 250V DC inductive (40ms)

OPERATION INDICATOR

The standard relay has a hand and remote reset magnetic disc (permanent memory) indicator fitted to give visual indication that the output relay element has operated.

INSULATION WITHSTAND in accordance with IEC 255-5:

2KV RMS & 1.2/50 5KV impulse between:

- ◆ all input terminals & frame
- ◆ all output terminals & frame
- ◆ all input & output terminals
- ◆ each input group
- ◆ each output group

NOISE IMMUNITY

Withstands the high frequency interference test detailed in IEC 255-22-1.

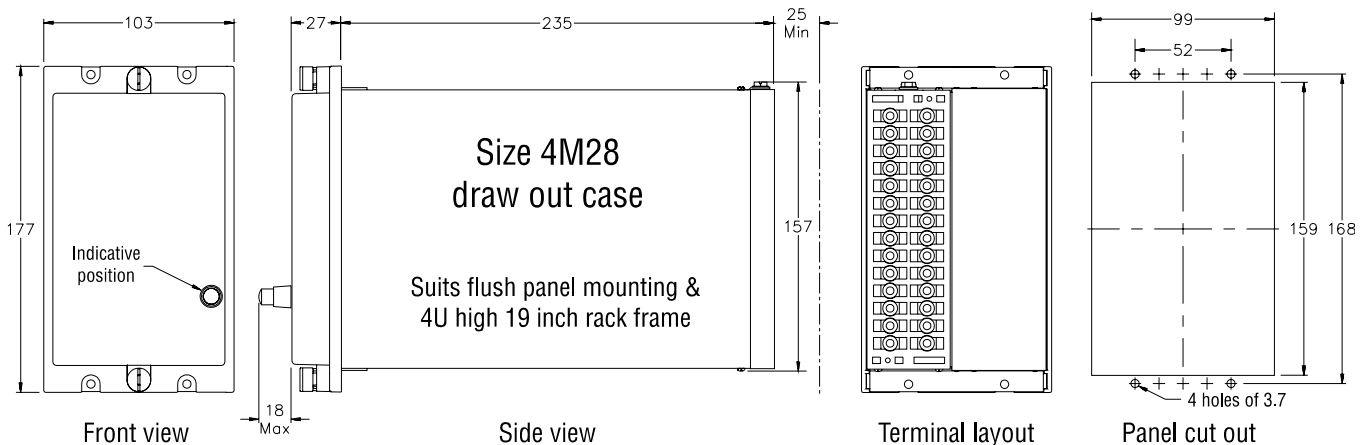

Ordering Information

Generate the required ordering code as follows: e.g. 2H33 DBA

2H33 1 2 3

Case Earth

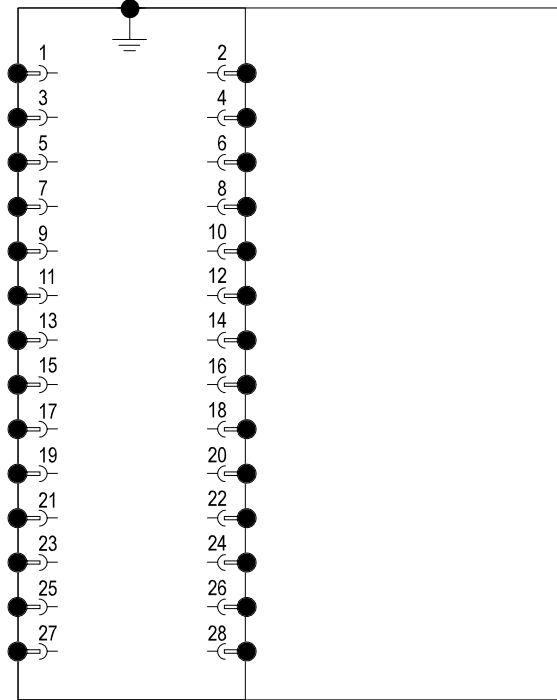

4M28 Case terminations (REAR VIEW)

1 AUXILIARY SUPPLY (-25% to + 20%)

- A 32V DC
- B 48V DC
- C 110V DC
- D 125V DC
- E 250V DC

2 FREQUENCY SENSING INPUT

- A 63.5V AC
- B 110V AC

3 ENCLOSURE STYLE

- A 4M28 case for 4U high rack mount and flush mounting

3U High 19" Rack type with multiple modules (1M style)

- B 1M330 Rack only without sensing modules
- C 1M331 One module in 3U high 19" rack
- D 1M332 Two modules in 3U high 19" rack
- E 1M333 Three modules in 3U high 19" rack
- F 1M334 Four modules in 3U high 19" rack
- G Plug in sensing module only

1M style racks are fitted with a clear dust seal cover is fitted over the control settings & rail mounted screw-clamp type terminals are provided at the rear for external connections.

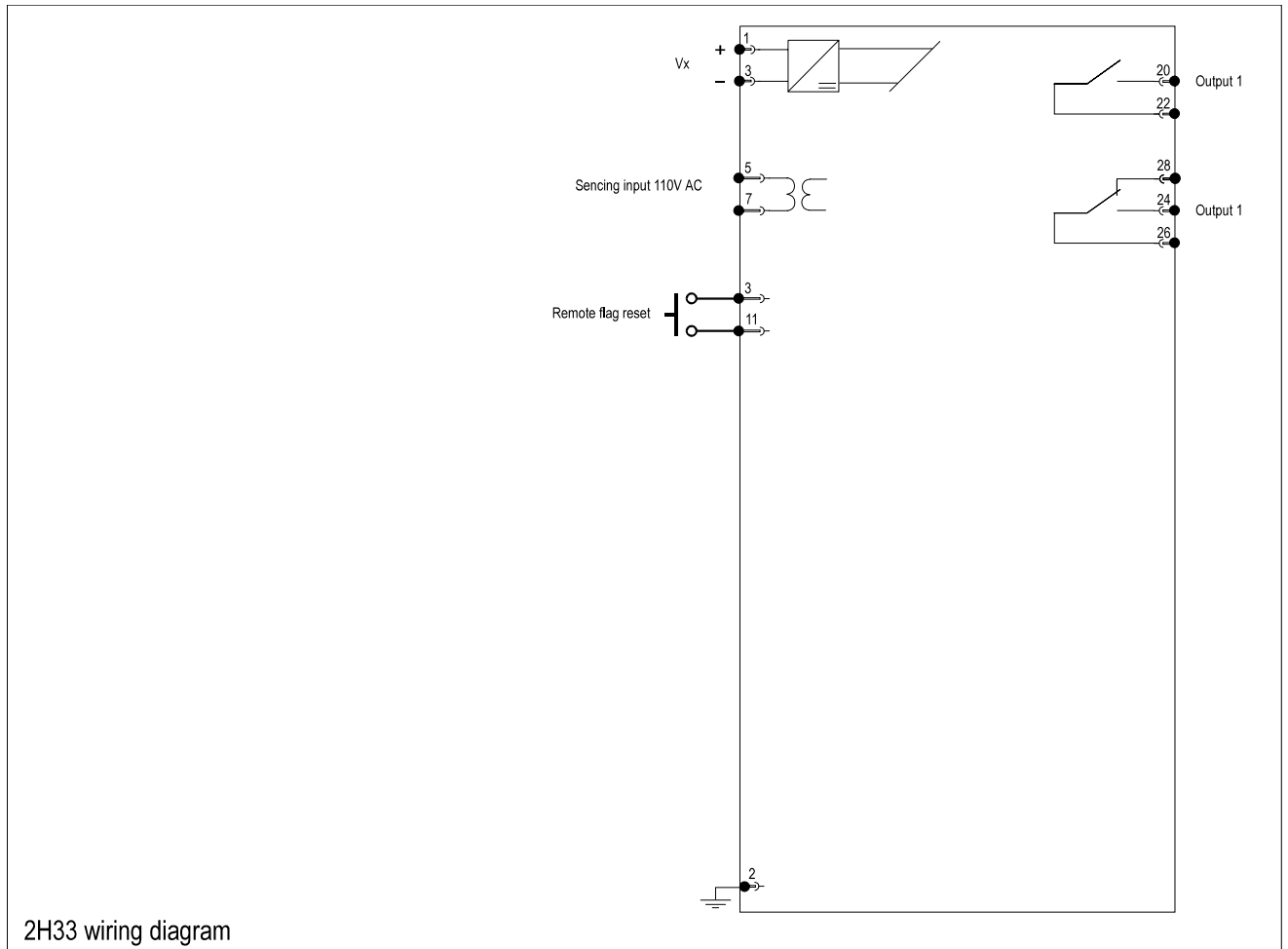

2H33 wiring diagram

Australian Content

Unless otherwise stated the product(s) quoted are manufactured by RMS at our production facility in Melbourne Australia. Approximately 60% of our sales volume is derived from equipment manufactured in house with a local content close to 90%. Imported components such as semi-conductors are sourced from local suppliers & preference is given for reasonable stock holding to support our build requirements.

Quality Assurance

RMS holds NCSI (NATA Certification Services International), registration number 6869 for the certification of a quality assurance system to AS/NZS ISO9001-2000. Quality plans for all products involve 100% inspection and testing carried out before despatch. Further details on specific test plans, quality policy & procedures may be found in section A4 of the RMS product catalogue.

Product Packaging

Protection relays are supplied in secure individual packing cardboard boxes with moulded styrene inserts suitable for recycling. Each product & packing box is labeled with the product part number, customer name & order details.

Design References

The products & components produced by RMS are based on many years of field experience since Relays Pty Ltd was formed in 1955. A large population of equipment is in service throughout Australia, New Zealand, South Africa & South East Asia attesting to this fact. Specific product & customer reference sites may be provided on application.

Product Warranty

All utility grade protection & auxiliary relay products, unless otherwise stated, are warranted for a period of 24 months from shipment for materials & labour on a return to factory basis. Repair of products damaged through poor application or circumstances outside the product ratings will be carried out at the customer's expense.

Standard Conditions of Sale

Unless otherwise agreed RMS Standard Terms & Conditions (QF 907) shall apply to all sales. These are available on request or from our web site.



Relay Monitoring Systems Pty Ltd

6 Anzed Court, Mulgrave, Victoria 3170, AUSTRALIA

Tel: 61 3 9561 0266 Fax: 61 3 9561 0277 Email: rms@rmspl.com.au Web: www.rmspl.com.au