

Features

- Large back lit display panel
- High resolution frequency & voltage display readout
- Four independent frequency stages
- Independent time delay per frequency stage
- 41 to 59Hz PU setting range
- 63.5/110V AC nominal inputs
- Four independent rate of change dF/dt detection stages
- Independent definite time delay per dF/dt stage
- Adjustable dF/dt sample measurement time to optimize accuracy & response time
- Timing & trip indication LED's
- Separate overvoltage & undervoltage alarm stages with independent output relays
- Undervoltage blocking function
- Relay enable input
- CPU watchdog
- Wide auxiliary supply range with fail alarm contact

COMMUNICATION

- USB front programming port
- Non platform specific PC programming software uMATRIXwin
- Optically isolated communication ports
- MODBUS RTU compatible protocol on RS485 or RS232 network port
- Size 4M56-S draw out case

Application

Reduction in system frequency is an early indicator of impending system voltage collapse. This can lead to plant & equipment damage if not taken off line or the frequency / voltage level restored. The 2H34 relay can be used to provide four stages of load shedding as the frequency progressively falls through the four independent setting stages. A rate of frequency change ROCOF element (dF/dt), can also be established for each stage for the detection of very fast frequency loss due to disconnection from the mains grid.

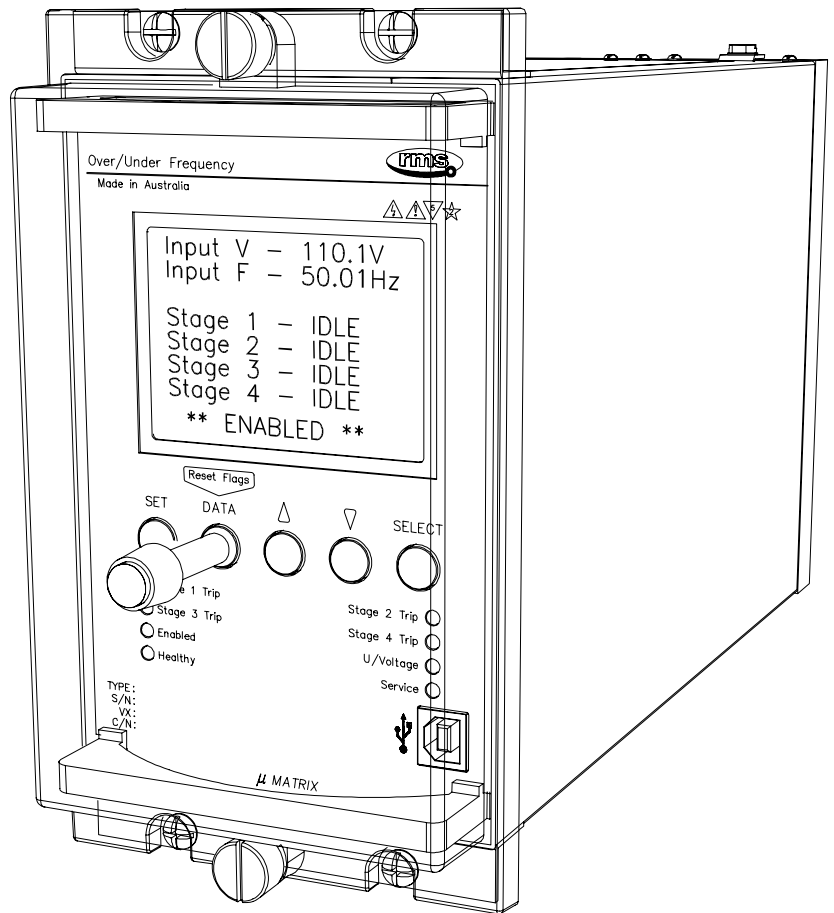

2H34 depicted in a 4M56-S draw out case

Operation

Made in Australia

The 2H34 Series relay is a frequency monitoring relay with four stages of adjustable frequency pick up & drop out points. Each frequency set point can be set for under or over frequency operation & has an independent time delay driving an output relay. An undervoltage lockout is used to disable the four frequency outputs when the voltage falls below a preset level.

A single status input is used to enable the four frequency sensing stages.
A second status input is used to reset the front panel latched LED trip indicators.

Each of the four setting stages has a rate of change of frequency (ROCOF) element with an independent time delay. The dF/dt element is available to operate as an AND or an OR logic function with the frequency element driving a common output contact per stage.

A separate Under Voltage & Over Voltage stage are provided for alarm functions.

The 2H34 relay is built on the Micro MATRIX digital platform. The standard Micro MATRIX human machine interface (HMI) is combined with fully solid state voltage sensing & measuring circuitry to provide high accuracy, simple set up & flexible operation. Self-monitoring is carried out by hardware & software watchdogs. A CPU software watchdog records abnormal events & performs automatic periodic checks. High speed, high contact rating output relays are used.

The input transformer, output relays & opto isolated status input form the essential barriers against high voltage line transients while a switchmode auxiliary supply provides a wide operating range.

A front panel USB programming port is provided for ease of establishing relay settings using a PC & uMATRIXwin which is available free of charge.

SENSING INPUT

Nominal VT sensing input: 1 phase 63.5 & 110V AC
 Sensing supply burden: Less than 0.2VA
 Thermal rating: 300V continuous

RELAY FAIL ALARM

A C/O alarm contact is maintained in the energized state when all of the following conditions are met:

- The auxiliary supply is applied
- The internal 24V DC rail is within acceptable limits
- The CPU hardware watchdog maintains a pulsing output

A CPU software watchdog records "suspect" events to an assert register and if necessary performs a soft restart.

RELAY ENABLE STATUS INPUT

The status input on the 2H34 is used to enable the four frequency monitoring stages of the relay. The relay must be "enabled" in order for the time delay stages to operate. A front panel LED is illuminated red when the relay is disabled.

STATUS INPUT FUNCTION

The status input function is factory set to enable on the application of a control voltage. It is also possible for the status input to operate on the removal of a control voltage by simply changing a software flag in the PC setup program.

STATUS INPUT MINIMUM OPERATING CURRENT

10 mA P/U for 1 ms then reducing to 1.5 mA after 4 ms.

STATUS INPUT OPERATING TIME

Initiate input	Parameter	Delay
DC	P/U	<4 ms
	D/O	<16 ms
AC	P/U	<23 ms
	D/O	<33 ms

Table 1

RESET TIME DELAY

An independent reset time setting (Treset), is provided for each of the four frequency stages. Treset may be adjustable between zero & 5s in 0.1s steps.

For instantaneous reset Treset should be set to zero.

When the frequency pick up & drop out points are set very close together it is advisable to set Treset with a small reset delay to avoid timer resetting due to transient voltage fluctuations.

The difference in timing performance is demonstrated in the following diagrams:

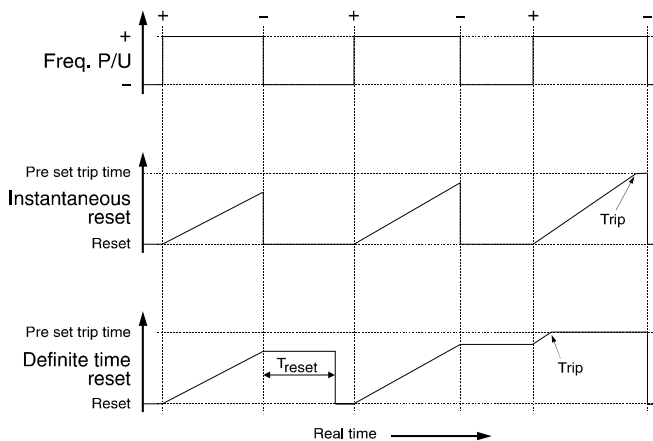

It should be noted that once the relay has timed out & the trip output initiated, the frequency element will reset instantaneously when the frequency pick up is reset irrespective of the Treset setting.

The reset characteristic for the voltage stages are instantaneous.

FREQUENCY STEP SET POINTS

Inputs: Single pole 63.5/110V AC nominal
 Setting stages: 4 independent stages
 Operating range: 40 to 60 Hz
 Setting range: 41 to 59Hz in 0.05Hz steps
 Measurement resolution: 0.01Hz at 50Hz
 Accuracy: +/-0.03Hz (70 to 121V) at 50Hz
 Hysterisis: 0.05 to 0.5Hz in 0.05Hz steps
 Frequency measuring time: 20ms (Add to time delay setting)
 Over frequency function: PU at set point
 Under frequency function: DO at set point – hysterisis +/-0.03Hz
 PU at set point
 DO at set point + hysterisis +/-0.03Hz

FREQUENCY STEP TIME DELAY SETTING

The 2H34 allows for a separate time range for each of the four frequency stage set points.

Setting range: 0.1 to 100s in 0.05s steps.
 Minimum operate time: 0.1s typical
 Timing error: <20ms + 0.1% of time delay setting

UNDER VOLTAGE LOCKOUT

An Under Voltage lockout feature is used to block all output stages in the event of voltage loss caused by a failed VT or fuse.

Setting range: 20 to 100V in 0.1V steps
 Accuracy: +/-250mV or +/-0.5% of setting
 Operate time: <70ms
 Hysterisis: 0.2 to 5V in 0.1V steps

UNDER VOLTAGE PROTECTION

An Under Voltage protection stage is available to monitor & trip if the pre set voltage level is reached.

Setting range: 20 to 110V in 0.1V steps
 Accuracy: +/-250mV or +/-0.5% of setting
 Operate time: <70ms
 Hysterisis: 0.2 to 5V in 0.1V steps

OVER VOLTAGE PROTECTION

An Over Voltage protection stage is available to monitor & trip if the pre set voltage level is reached.

Setting range: 110 to 140V in 0.1V steps
 Accuracy: +/-0.5% of setting
 Operate time: <70ms
 Hysterisis: 0.2 to 5V in 0.1V steps

OUTPUT STAGES

All contacts are self reset.

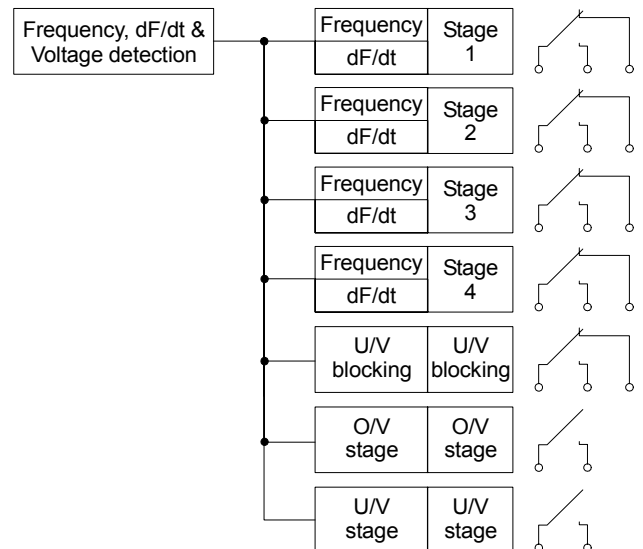

dF/dt FUNCTION

Rate of change of frequency known as ROCOF or dF/dt is a useful parameter for the fast detection of events such as disconnection of a generator from the grid.

Under such conditions it is unlikely that an under frequency element will operate fast enough to protect the power system before the frequency & voltage has dropped below acceptable limits.

dF/dt SAMPLING ENGINES

Performance of the dF/dt elements is dependant on the sampling time used to calculate & average the dF/dt reading.

dF/dt measurements are based on the difference between successive frequency readings recorded on each cycle of the AC signal being monitored.

dF/dt measurements based on 2 samples is required for fast response but is not suitable for detecting low dF/dt rates.

dF/dt measurements based on 5 samples is required to detect very slow dF/dt rates but is consequently slower to respond & is not suitable for detecting high dF/dt rates.

To allow dF/dt setting flexibility while remaining within the constraints described in Table 2, two dF/dt sampling engines (A & B) are provided:

- dF/dt activation: Set to ON or OFF
- Sample time A: 2 to 5 cycles in 1 cycle steps
- dF/dt rejection A: 0.2 to 18Hz/s in 0.1Hz/s steps
- Sample time B: 2 to 5 cycles in 1 cycle steps
- dF/dt rejection B: 0.2 to 18Hz/s in 0.1Hz/s steps

dF/dt REJECTION FUNCTION

A dF/dt rejection setting is provided to reject dF/dt readings above a user defined setting. This feature is used to reject spurious readings due to noise & transients to ensure stability & improve security particularly when using short delay times. When selecting a dF/dt rejection setting, consideration should be given to the maximum dF/dt rate expected on the system plus 1Hz/s. As a separate dF/dt rejection setting is available for each dF/dt engine, these may be set to approximately twice the maximum dF/dt P/U setting used for that engine.

dF/dt SET POINTS

Four independent dF/dt elements are provided. When this function is activated the dF/dt pick up is used to initiate an independent dF/dt timer.

- Setting stages: 4 independent stages
- Setting range: 0.13 to 9.0Hz/s in 0.1Hz/s steps
- dF/dt function: PU at set point
DO at set point – hysteresis
- dF/dt engine: Select dF/dt sampling engine A or B

dF/dt SETTING CRITERIA

Sample time (Cycles)	2	3	4	5
Maximum setting (Hz/s)	9	7	6	5
Minimum setting (Hz/s)	0.70	0.50	0.20	0.13
Minimum time delay setting	40ms	60ms	80ms	100ms
dF/dt Measurement time	70ms	100ms	150ms	200ms
Hysteresis (Hz/s)	0.24	0.12	0.07	0.05
Accuracy at 50Hz (Hz/s)	+/-0.2	+/-0.1	+/-0.07	+/-0.05
Timing accuracy	+/-30ms	+/-40ms	+/-50ms	+/-60ms

Table 2

dF/dt Function (ROCOF)

dF/dt MINIMUM & MAXIMUM SETTING

The dF/dt setting range is dependant on the sample time setting as shown in Table 2. Outside the specified setting range the stated accuracy is not met.

dF/dt TIME DELAY SETTING

The 2H34 allows for a separate time range for each of the four dF/dt stage set points.

- Setting range: 0.00 to 100s in 0.02s steps.
- Timing accuracy: Refer table 2.

The dF/dt element operate time is dependant on the sample time setting which determines the dF/dt measurement time shown in Table 2.

The actual operate time for each stage is the sum of the dF/dt measurement time + the dF/dt stage time delay setting +/- timing error.

A minimum dF/dt time delay setting equal to the sample time setting is recommended as per Table 2.

dF/dt FUNCTION LOGIC OPTIONS

Two global logic options are available:

The OR logic function requires either the frequency step element OR the dF/dt element to time out for the stage output relay to operate.

The AND logic function requires both the frequency step element AND the dF/dt element to time out for the stage output relay to operate.

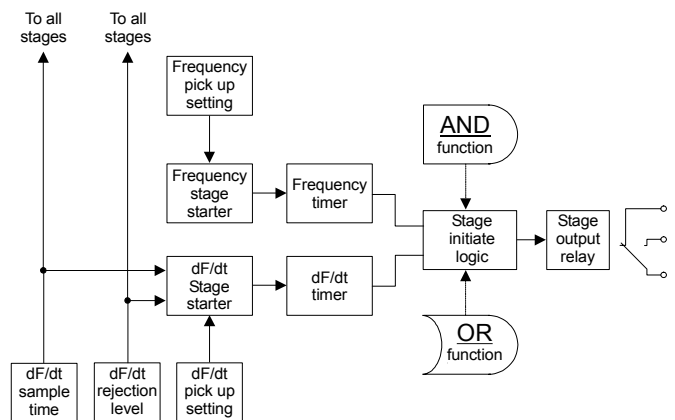

dF/dt ACCURACY

A typical dF/dt measurement sweep is depicted below using a sample time of 4 cycles which provides high measurement accuracy but & moderate response time.

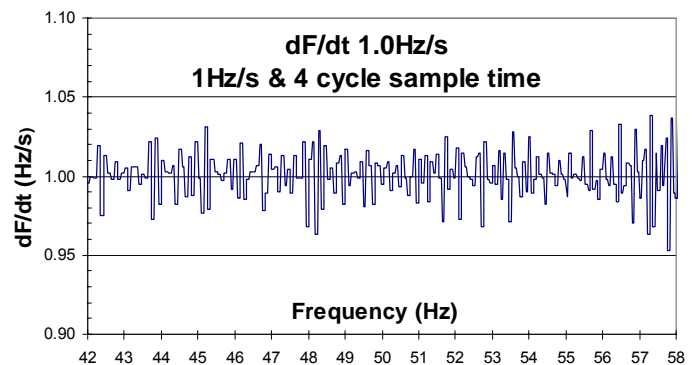

While random noise hits may cause spikes beyond the maximum error quoted these will not be of sufficient duration to cause a trip event due to the time delay setting & dF/dt rejection function.

Where very fast operate times are required for dF/dt rates above 0.70Hz/s, shorter sample times must be used at the expense of measurement accuracy. The dF/dt measurement accuracy for each sample time setting is shown in Table 2.



AUXILIARY SUPPLY

20-70V DC switchmode supply or
40-275V AC / 40-300V DC switchmode supply
Burden: <7 watts during timing
<10 watts with output relays energized

Inputs:

A high efficiency switchmode power supply is incorporated which provides a low burden to the auxiliary supply.

Input Transients:

Withstands multiple high-energy transients & ring waves in accordance with IEEE28 - ANSI C26.1 Cat. II, accordingly:

- 0.5uS 100kHz 6kV O/C, 500A S/C, 4J
- 1.2/50uS 6kV O/C
- 8/20uS 3kA S/C, 80J clamped at 1,000V

Mains conducted EMI within limits specified by AS 3548 Class B.

Isolation:

The inputs are isolated from the outputs in accordance with AS3260 Class II Limited Current Circuitry, accordingly:

- Withstand voltage of 2.5kV RMS 50Hz for one minute
- Creepage & clearance distance greater than 4mm
- Output leakage current less than 0.25A to earth

Output Protection:

Outputs will withstand continuous short circuit. Output regulators & switching control regulator are thermally protected.

Technical Data

OUTPUT CONTACT RATINGS

IEC60255-0-2

Carry continuously	5A AC or DC
Make & carry	0.5 s 20 A AC or DC
L/R \leq 40ms & V \leq 300V	0.2 s 30 A AC or DC
	AC resistive 1,250 VA
Break capacity	AC inductive 250 VA @ PF \leq 0.4
I \leq 5A & V \leq 300V	DC resistive 75 W
	DC inductive 30 W @ L/R \leq 40 ms
	50 W @ L/R \leq 10 ms
	10 ⁶ at maximum load
Minimum number of operations	0.5W limit 10mA / 5 V
Minimum recommended load	

TRANSIENT OVERVOLTAGE

IEC60255-5 CLASS III

Between all terminals & earth	5 kV 1.2/50 us 0.5 J
Between independent circuits without damage or flashover	5 kV 1.2/50 us 0.5 J

INSULATION COORDINATION

IEC60255-5 CLASS III

Between all terminals & earth	2.0 kV rms for 1 min.
Between independent circuits	2.0 kV rms for 1 min.
Across normally open contacts	1.0 kV rms for 1 min.

AUXILIARY SUPPLY

IEC60255-11

Allowable breaks / dips in supply	\leq 20 ms
Collapse to zero from nominal voltage	

HIGH FREQUENCY DISTURBANCE

IEC60255-22-1 CLASS III

2.5 kV 1MHz common mode	\leq 3% variation
1.0 kV 1MHz differential mode	

ELECTROSTATIC DISCHARGE

IEC60255-22-2 CLASS III

6 kV contact discharge	\leq 5% variation
------------------------	---------------------

RADIO FREQUENCY INTERFERENCE

IEC60255-22-3

10 V/m, 80 TO 1,000 MHz	\leq 5% variation
-------------------------	---------------------

FAST TRANSIENT

IEC60255-22-4

4 kV, 5/50 ns, 100 KHz repetitive	\leq 3% variation
-----------------------------------	---------------------

CONDUCTED RFI

IEC60255-22-6

10 V, 0.15 to 80 MHz	\leq 5% variation
----------------------	---------------------

TEMPERATURE RANGE

Operating:	-5 to +55°C
Storage:	-25 to +75°C

HUMIDITY

IEC68-2-1/2

40°C & 95% RH non condensing

CASE

Size 4 draw out
56 M4 screw terminals
Flush panel mount or 4U high 1/4 width 19 inch rack mount
IP51 rating

ACCESSORIES SUPPLIED

1 x M4 self threading mounting screw kit	P/N 290-406-151
2 x M4 terminal screw kit (28 per kit)	P/N 290-407-153
1 x μ MATRIX User Guide per order	
1 x CD - μ MATRIXwin software, setting files & applications per order	



Visit www.rmspl.com.au for the latest product information.

Due to RMS continuous product improvement policy this information is subject to change without notice. 2H34-S/Issue C/19/08/09 - 4/6

Communications

COMMUNICATION PORTS

Two (2) communications ports are available. The front USB programming port is provided as standard while the rear RS485 network port is available as an option.

Programming port

The programming port is accessible from the front panel of the relay via a USB physical link & PC configuration program supplied with the relay. The μ MATRIXwin configuration program is designed to operate with all relays from the μ MATRIX range & with all installed firmware version.

Network port

The network port is intended for applications where permanent connection to a master control system is required. An optically isolated RS485 physical layer is provided for this function.

The RS485 connection is intended for applications where multiple μ MATRIX relays are to be connected on a common communications bus.

Network Port Terminating Resistor

Where multiple relays are connected in a multi-drop configuration the RS485 comms. bus must have a 120 ohm terminating resistor fitted at each end. If the μ MATRIX-S relay is at one end of the transmission line a terminating resistor can be added by placing SW100-3 and SW100-4 in the ON position as depicted in the wiring diagram.

Network Port BIAS Resistors

Where a single relay is connected to the network, or where the relay is a long distance from other devices on the comms. bus, BIAS resistors may need to be fitted to ensure reliable operation. To simplify this configuration, BIAS resistors are fitted to each μ MATRIX-S relay and may be selected IN by setting switches SW100-1 and SW100-2 to the ON position as depicted in the wiring diagram. This bank of four switches can be accessed by withdrawing the relay module from its case, turning upside down and looking at the centre PCB near the rear terminal blocks.

PC TO μ MATRIX USB CONNECTION

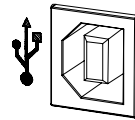

2V164-S front panel USB programming port

USB DRIVERS

The μ MATRIX-S USB port is configured as a Virtual Communications Port (VCP) & is operated through a PC COM port. USB drivers must be installed on the PC to enable correct communication. A ZIP file containing the driver files needed for this process may be downloaded from:

www.rmspl.com.au/umatrix

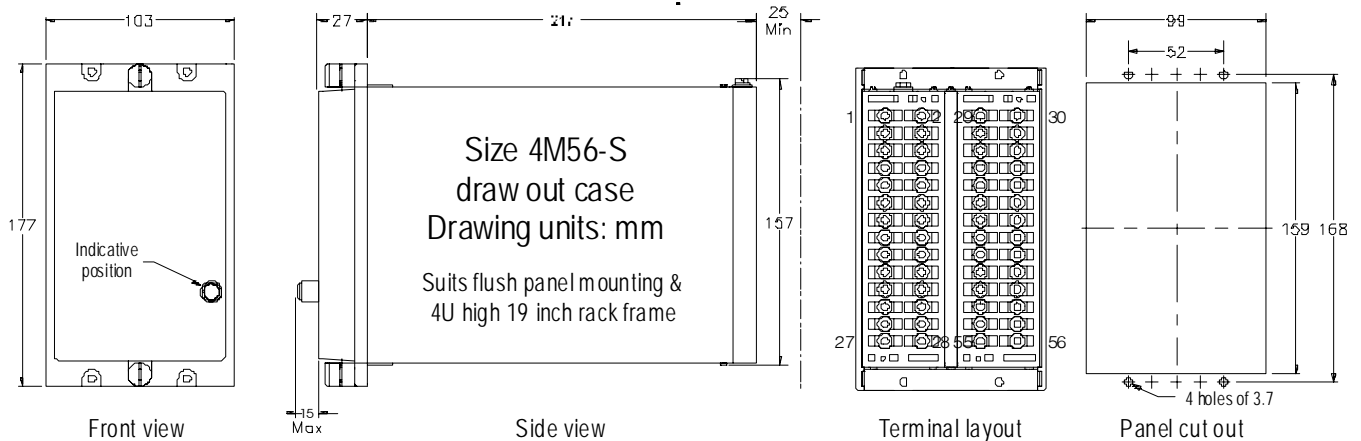

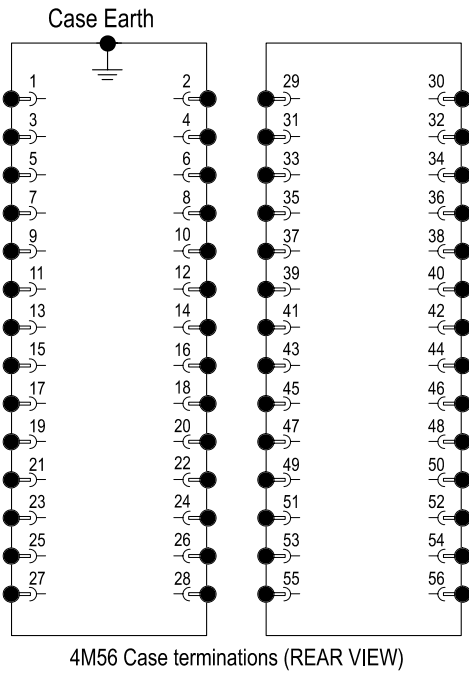

Ordering Information

Generate the required ordering code as follows: e.g. 2H34-S-BDDA

General Type	Order Code			
	1	2	3	4
2H34-S				

1 AUXILIARY SUPPLY RANGE

- A 20-70V DC
- B 40-275V AC (300V DC)

2 RELAY INITIATE INPUT

- A 24-80V AC/DC
- B 80-150V AC/DC
- C 150-275V AC (300V DC)
- D 18-275V AC (300V DC)

3 REMOTE FLAG RESET INPUT

- A 24-80V AC/DC
- B 80-150V AC/DC
- C 150-275V AC (300V DC)
- D 18-275V AC (300V DC)

4 REAR COMMUNICATIONS PORT

- A Not required
- B Required – Modbus protocol

! REQUEST DEFAULT APPLICATION SOFTWARE

- A UMX2H34A Frequency OR dF/dt output logic function
- B UMX2H34B Frequency AND dF/dt output logic function

*Note: The status inputs & some relay outputs are assigned by the software (UMX) loaded on the relay.

Shown here are the standard terminal assignments of the A UMX. Other UMX versions may differ. Consult the UMX manuals for specific I/O assignments.

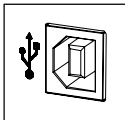

FRONT PANEL
USB PROGRAMMING
PORT

SCADA
COMMUNICATIONS
PORT

RS485
Network port



To other μ MATRIX relays (Up to 32 units)
Invoke terminating 120R resistor to end of BUS relay only.
To do this set SW100-1&2 ON.

Invoke BIAS resistors for single relay connection only.
To do this set SW100-3&4 ON.

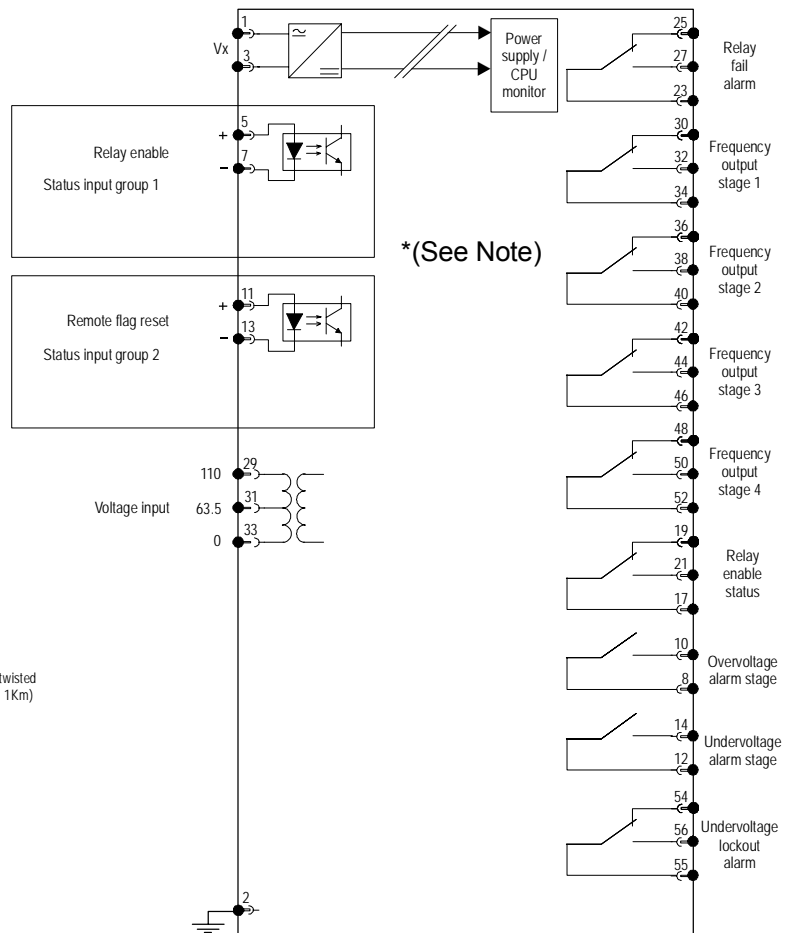

2H34 wiring diagram - Relay shown in de-energised condition

Australian Content

Unless otherwise stated the product(s) quoted are manufactured by RMS at our production facility in Melbourne Australia. Approximately 60% of our sales volume is derived from equipment manufactured in house with a local content close to 90%. Imported components such as semi-conductors are sourced from local suppliers & preference is given for reasonable stock holding to support our build requirements.

Quality Assurance

RMS holds NCSI (NATA Certification Services International), registration number 6869 for the certification of a quality assurance system to AS/NZS ISO9001-2000. Quality plans for all products involve 100% inspection and testing carried out before despatch. Further details on specific test plans, quality policy & procedures may be found in section A4 of the RMS product catalogue.

Product Packaging

Protection relays are supplied in secure individual packing cardboard boxes with moulded styrene inserts suitable for recycling. Each product & packing box is labeled with the product part number, customer name & order details.

Design References

The products & components produced by RMS are based on many years of field experience since Relays Pty Ltd was formed in 1955. A large population of equipment is in service throughout Australia, New Zealand, South Africa & South East Asia attesting to this fact. Specific product & customer reference sites may be provided on application.

Product Warranty

All utility grade protection & auxiliary relay products, unless otherwise stated, are warranted for a period of 24 months from shipment for materials & labour on a return to factory basis. Repair of products damaged through poor application or circumstances outside the product ratings will be carried out at the customer's expense.

Standard Conditions of Sale

Unless otherwise agreed RMS Standard Terms & Conditions (QF 907) shall apply to all sales. These are available on request or from our web site.



Relay Monitoring Systems Pty Ltd

6 Anzed Court, Mulgrave, Victoria 3170, AUSTRALIA

Tel: 61 3 9561 0266 Fax: 61 3 9561 0277 Email: rms@rmspl.com.au Web: www.rmspl.com.au