

Features

- Detects phase angle imbalance
- Detects reverse phase sequence
- Detects supply under voltage
- Unaffected by frequency variations of $\pm 5\text{Hz}$
- Adjustable 5-15% out of balance setting
- 415V 50Hz standard
- Other optional detection voltages & frequencies
- No auxiliary voltage required
- Fail safe operation (Contact normally picked up)
- Filter rejects harmonics & control tones
- Optional true time delay off function available
- Made in Australia

Description

The 2P40 relay is a phase failure relay suitable for 3 phase supplies. The relay is designed to provide protection for rotating equipment from the damaging effects of excessive negative sequence voltage resulting from phase failure, phase unbalance and reversed phase sequence. The 2P40 output relay is normally energised and drops out when phase angle unbalance is greater than the pre-set, under voltage or reverse phase sequence.

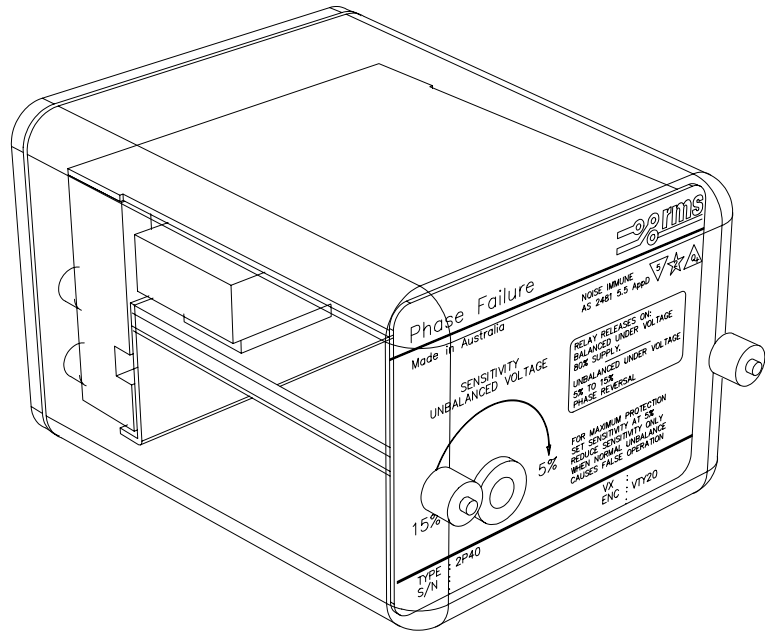
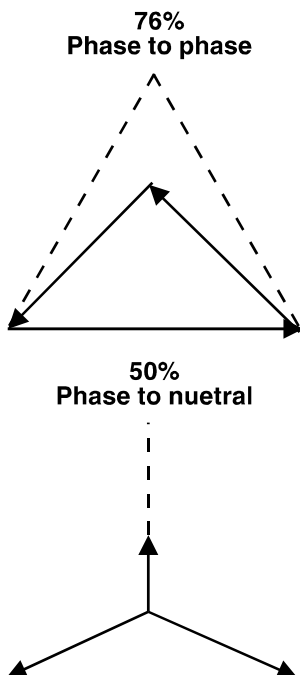

2P40 relay depicted in a VY enclosure

Applications

Made in Australia

MOTOR PROTECTION

The 2P40 phase failure relay has the sensitivity to detect the voltage unbalance caused by a motor single phasing. In most instances even a motor with no load and no other loads connected to the open phase will be detected when single phasing. In using the 2P40 relay it must be realised that it only monitors the supply voltage at the point of connection and therefore provides no protection for single phasing due to faulty switchgear, connections or blown fuses etc., on the load side of this point. The 2P40 relay is ideal for detecting phase failure and unbalance of HT lines and for this purpose 110V relays are also available. As the 2P40 detects the presence of negative sequence voltage a relay connected on the load side of a three phase transformer will detect a blown fuse or high impedance in one phase of the supply to the transformer, regardless of the transformer winding connections. Pump motors on the end of a HT line with fuse protection and therefore high probability of single line outages are an obvious application for the 2P40 relay.

PHASE REVERSAL PROTECTION

The 2P40 relay can be used for transportable cranes, refrigerated transporters, etc., which on being connected from one supply to another require phase reversal protection. The advantage of the 2P40 for this application is the added protection of phase failure and under voltage.

3 PHASE UNDER VOLTAGE

It is a useful under voltage relay in that phase angles are also monitored. As an example three single phase under voltage relays may not detect an open phase which is connected to a healthy phase through a low impedance load. The 2P40 relay however will detect this condition due to the change in phase angles. In using the 2P40 relay as an under voltage relay it must be remembered that only the B-Y voltage is monitored directly. The other two \emptyset to \emptyset voltages are monitored for correct phase angle and voltage balance with respect to the B-Y voltage. The difference in percentage under voltage expressed as phase to phase and phase to neutral must also be appreciated. As a guide, when two \emptyset to \emptyset voltages are equally reduced as shown - the relationship is as follows:

- 95% \emptyset to \emptyset = 90% \emptyset to N
- 90% \emptyset to \emptyset = 80% \emptyset to N
- 85% \emptyset to \emptyset = 69% \emptyset to N

PRINCIPLE OF OPERATION

The unit consists of a simple RC circuit across the R-Y phase such that point x will only be at the same potential as point p for a balanced supply of correct phase sequence. The solid state relay circuit is designed to release the relay at either a set out of balance voltage (X-P voltage), or a set under voltage of the B-Y phase (relay supply). Special filtering circuitry is used to prevent high frequency or ripple control signals from affecting the operation of the relay.

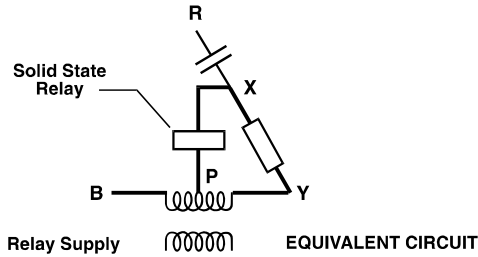
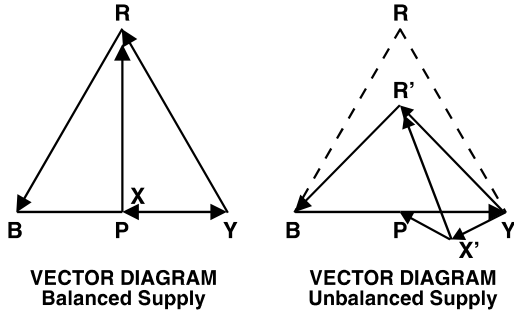

Technical Data

OUT OF BALANCE SETTING

Adjustable 5-15% expressed as phase to phase voltage difference as a % of nominal voltage when two phase to phase voltages are reduced equally with the third at nominal voltage. The equivalent negative sequence voltage expressed as a % of nominal phase to neutral voltage would be 10-31%. (Other settings are available to order.)

UNDER VOLTAGE SETTING

80% fixed - expressed as phase to phase voltage % of nominal voltage. (Other settings are available to order)

ACCURACY

±3% of setting

CONTACTS

1 C/O plus 1 N/O.

AMBIENT OPERATING TEMPERATURE RANGE

-5 to 55 degrees Celsius

STANDARD OUTPUT CONTACTS (Idec RH PCB mounting type)

Maximum Contact Capacity (Amps)

	DC			AC		
	30	125	250	110	220	250
Voltage						
Resistive	10	2.4	1.2	10	7	6.6
Inductive L/R 7ms	7.5	1.8	0.9	7.5	5	4.4

Make & Carry for 200ms

30A at 250V DC resistive

Maximum Break Capacity

0.34A at 250V DC inductive (40ms)

OPTIONAL 6R RELAY CONTACT RATINGS

Make & Carry Continuously

3,000 VA AC resistive with maximums of 660V & 12A
3,000 W DC resistive with maximums of 660V & 12A

Make & Carry for 3 Seconds

7,500 VA AC resistive with maximums of 660V & 30A
7,500 W DC resistive with maximums of 660V & 30A

AC Break Capacity

3,000 VA AC resistive with maximums of 660V & 12A

DC Break Capacity (Amps)

Voltage			24V	48V	125V	250V
Resistive rating	a	12	1.5	0.5	0.25	
	b	12	12	10	5	
L/R=40ms	Maximum break	a	12	1	0.25	0.15
		b	30	15	5.5	3.5
	1K operations (N3 Rating)	b	12	12	5	2.5

a = Without magnetic blowouts b = With magnetic blowouts

INSULATION WITHSTAND

In accordance with IEC 255-5:

2KV RMS between input and frame, output and frame, and output and input. 1.2/50 5KV impulse between each terminal and earth, between circuits not normally connected together and between terminals of the same circuit.

NOISE IMMUNITY

Withstands the high frequency interference test detailed in IEC 255-22-1.

AMBIENT OPERATING TEMPERATURE RANGE

-5 to 55 degrees Celsius

Ordering Information

Generate the required ordering code as follows: e.g. 2P40-ABBBA

2P40

1	2	3	4

1 SENSING SUPPLY - 3 Phase 3 or 4 wire (3 wire connection)

- A 110V 50Hz
- B 415V 50Hz
- C 440V 50Hz

2 TIME DELAY (2s approx.)

- A Required
Recommended for voltage selection schemes.
- B Not required

3 OUTPUT CONTACTS

- A Idec RH type output relay
- B Heavy duty 6R output relay
Required for voltage selection schemes.
- C 6R output relay with magnetic blowouts

4 FLAG

- A Required – hand reset
- B Not required
- C Required – self reset

5 ENCLOSURE STYLE

- A Front Connection UYT9
- B Back connection VYT20

6 CONNECTION TERMINALS

- A 2BA studs
- B 2BA screws
- C 4BA screws fitted for UYT9 enclosure

Australian Content

Unless otherwise stated the product(s) quoted are manufactured by RMS at our production facility in Melbourne Australia. Approximately 60% of our sales volume is derived from equipment manufactured in house with a local content close to 90%. Imported components such as semi-conductors are sourced from local suppliers & preference is given for reasonable stock holding to support our build requirements.

Quality Assurance

RMS holds NCSI (NATA Certification Services International), registration number 6869 for the certification of a quality assurance system to AS/NZS ISO9001-2000. Quality plans for all products involve 100% inspection and testing carried out before despatch. Further details on specific test plans, quality policy & procedures may be found in section A4 of the RMS product catalogue.

Product Packaging

Protection relays are supplied in secure individual packing cardboard boxes with moulded styrene inserts suitable for recycling. Each product & packing box is labeled with the product part number, customer name & order details.

Design References

The products & components produced by RMS are based on many years of field experience since Relays Pty Ltd was formed in 1955. A large population of equipment is in service throughout Australia, New Zealand, South Africa & South East Asia attesting to this fact. Specific product & customer reference sites may be provided on application.

Product Warranty

All utility grade protection & auxiliary relay products, unless otherwise stated, are warranted for a period of 24 months from shipment for materials & labour on a return to factory basis. Repair of products damaged through poor application or circumstances outside the product ratings will be carried out at the customer's expense.

Standard Conditions of Sale

Unless otherwise agreed RMS Standard Terms & Conditions (QF 907) shall apply to all sales. These are available on request or from our web site.



Relay Monitoring Systems Pty Ltd

6 Anzed Court, Mulgrave, Victoria 3170, AUSTRALIA

Tel: 61 3 9561 0266 Fax: 61 3 9561 0277 Email: rms@rmspl.com.au Web: www.rmspl.com.au