

Features

- Detects phase angle imbalance
- Detects reverse phase sequence
- Detects supply undervoltage
- Unaffected by frequency variations of $\pm 5\text{Hz}$
- Adjustable 5-15% out of balance setting
- 110V 50Hz or 60Hz versions
- Other optional detection voltages & frequencies
- No auxiliary voltage required
- Failsafe operation (Contact normally picked up)
- Filter rejects harmonics & control tones
- Front panel indicators to show healthy incoming & outgoing supplies
- Optional time delay on / off
- Size 4 rack or flush mount draw out case

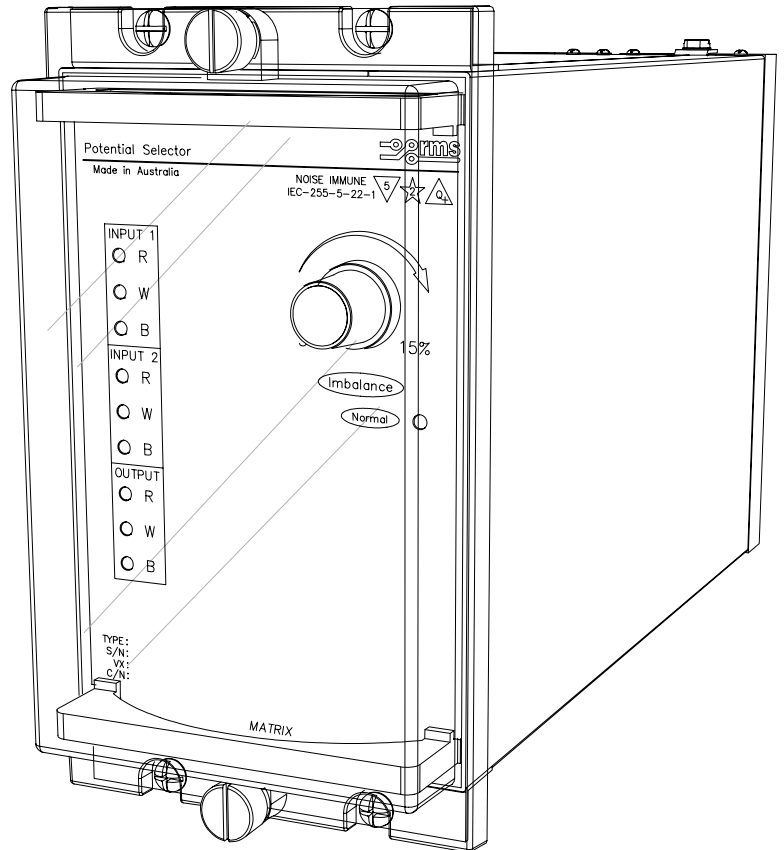

2P48 depicted in a 4M28 draw out case

Description

Made in Australia

The 2P48 relay is a phase failure relay suitable for 3 phase supplies when a neutral is available.

An internal relay allows for automatic changeover from a primary to secondary 3 phase supply when a fault is detected in the primary supply.

An additional alarm contact & front panel LED indicators are provided for ease of fault diagnosis.

Where a neutral connection is not available the 2P49 relay may be specified in auto changeover configuration. Functionality is the same except that the front panel LED indicators are not provided. The 2P49 in this configuration has the same output wiring as the 2P48 with the neutral connections deleted.

For 3 phase supplies other than 110V the 2P49 relay in auto changeover configuration is recommended: www.rmspl.com.au/2p49.htm

PRINCIPLE OF OPERATION

The unit consists of a simple RC circuit across the R-Y phase such that point x will only be at the same potential as point p for a balanced supply of correct phase sequence. The solid state relay circuit is designed to release the relay at either a set out of balance voltage (X-P voltage), or a set undervoltage of the B-W phase (relay supply). Special filtering circuitry is used to prevent high frequency or ripple control signals from affecting the operation of the relay.

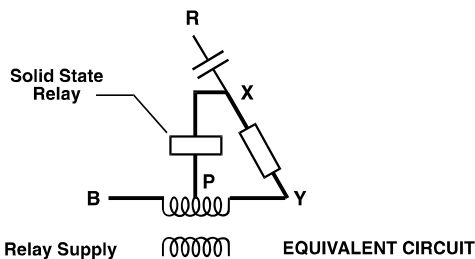
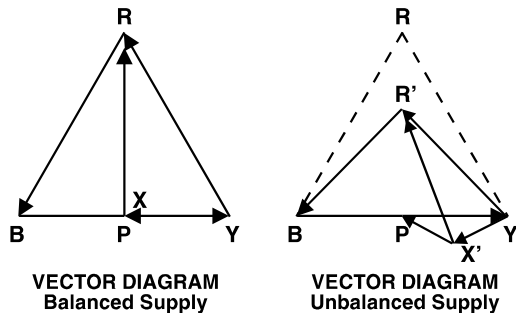

NEGATIVE PHASE SEQUENCE

The relay will drop out when the negative phase sequence value corresponding to the relay setting shown below for the 110V AC is reached.

Setting (%)	Ph-Ph (V)	Ph-N (V)	Negative Phase Sequence
5	104.5	57.10	3.48%
6	103.4	55.80	4.21%
7	102.3	54.50	4.96%
8	101.2	53.19	5.72%
9	100.1	51.88	6.50%
10	99.0	50.56	7.29%
11	97.9	49.23	8.10%
12	96.8	47.90	8.92%
13	95.7	46.56	9.76%
14	94.6	45.21	10.62%
15	93.5	43.86	11.50%

Negative phase sequence chart – 110V AC

PHASE REVERSAL PROTECTION

The 2P48 relay can be used for transportable cranes, refrigerated transporters, etc., which on being connected from one supply to another require phase reversal protection. The advantage of the 2P48 for this application is the added protection of phase failure and undervoltage.

AUTO VOLTAGE CHANGEOVER SCHEME

The 2P48 relay is designed to automatically change over from a primary 3 phase supply to a secondary 3 phase supply if any phase of the primary supply has faulted. The 2P48 output relay is normally energized by the primary supply & drops out when phase angle unbalance is greater than the pre-set, for under voltage or for reverse phase sequence.

Recovery of the primary supply to a healthy condition will cause the relay to change back to the primary supply. An optional 2s timer may be specified to delay the transition from primary to secondary supplies in both directions.

A front panel LED will indicate the faulted phase thus allowing fault recognition. Each of the incoming phases for both primary and secondary supplies have LED's for each phase to indicate healthy supplies. The LEDs will extinguish for the following conditions:

- Excessive negative sequence voltage resulting from phase failure;
- Phase unbalance;
- Reversed phase sequence.

3 PHASE UNDERVOLTAGE

The 2P48 is a useful undervoltage relay in that phase angles are also monitored. As an example three single phase undervoltage relays may not detect an open phase which is connected to a healthy phase through a low impedance load. The 2P48 relay however will detect this condition due to the change in phase angles. In using the 2P48 relay as an undervoltage relay it must be remembered that only the B-W voltage is monitored directly. The other two \emptyset to \emptyset voltages are monitored for correct phase angle and voltage balance with respect to the B-W voltage. The difference in percentage undervoltage expressed as phase to phase and phase to neutral must also be appreciated. As a guide, when two \emptyset to \emptyset voltages are equally reduced as shown - the relationship is as follows:

- 95% \emptyset to \emptyset = 90% \emptyset to N
- 90% \emptyset to \emptyset = 80% \emptyset to N
- 85% \emptyset to \emptyset = 69% \emptyset to N

IMBALANCE SETTING

Adjustable 5-15% expressed as phase to phase voltage difference as a % of nominal voltage when two phase to phase voltages are reduced equally with the third at nominal voltage.

The imbalance dial is calibrated for drop off at each end of the scale; the user should set the control as fine as possible (5% end), to the point where the voltage dips on the system caused by varying loads do not cause the relay to drop out.

UNDERVOLTAGE SETTING

80% fixed - expressed as phase to phase voltage % of nominal voltage. (Other settings are available to order)

ACCURACY

±3% of 5 - 15% of nominal

TIME DELAY

Refer to the Order Code section to select instantaneous operation or 2s, 5s or 10s time delays for operation on pick up, drop off or on both pick up & drop off.

All time delays are approximate.

CASE

Size 4M28-S draw out case suitable for 4U 19 inch rack or flush mounting.

Technical Data

BURDEN 110V AC with relay picked up
 R∅ 2.2VA
 W∅ 8VA
 B∅ 7VA

CONTACTS

4 C/O voltage selection contacts
 1 C/O alarm output contact.

6R RELAY CONTACT RATINGS

Make & Carry Continuously

3,000 VA AC resistive with maximums of 660V & 12A
 3,000 W DC resistive with maximums of 660V & 12A

Make & Carry for 3 Seconds

7,500 VA AC resistive with maximums of 660V & 30A
 7,500 W DC resistive with maximums of 660V & 30A

AC Break Capacity

3,000 VA AC resistive with maximums of 660V & 12A

DC Break Capacity (Amps)

Voltage			24V	48V	125V	250V
Resistive rating	a	12	1.5	0.5	0.25	
	b	12	12	10	5	
L/R=40ms	Maximum break	a	12	1	0.25	0.15
		b	30	15	5.5	3.5
1K operations (N3 Rating)	a	12	12	5	2.5	
	b	12	12	5	2.5	

a = Without magnetic blowouts b = With magnetic blowouts

INSULATION WITHSTAND in accordance with IEC 255-5:

2KV RMS & 1.2/50 5KV impulse between:

- ◆ all input terminals & frame
- ◆ all output terminals & frame
- ◆ all inputs & alarm contact output terminals

NOISE IMMUNITY

Withstands the high frequency interference test detailed in IEC 255-22-1.

AMBIENT OPERATING TEMPERATURE RANGE

-5 to 55 degrees Celsius

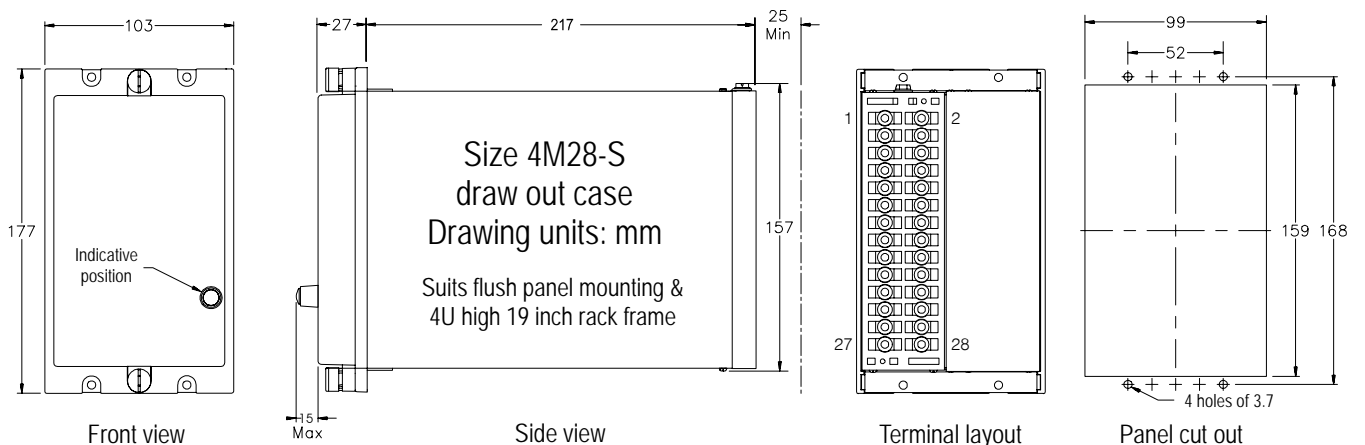

Ordering Information

Generate the required ordering code as follows: e.g. 2P48 ABB

2P48 1 2 3

1 SENSING SUPPLY - 3 Phase 4 wire (Neutral required)

- A 110V 50Hz
- C 110V 60Hz

2 TIME DELAY

- A 2s delay on drop off
- B Not required
- C 5s delay on drop off
- D 10s delay on drop off
- E 2s delay on pick up
- F 5s delay on pick up
- G 10s delay on pick up
- H 2s delay on pick up & drop off
- I 5s delay on pick up & drop off
- J 10s delay on pick up & drop off

3 MAGNETIC BLOWOUTS

- A Required
- B Not required

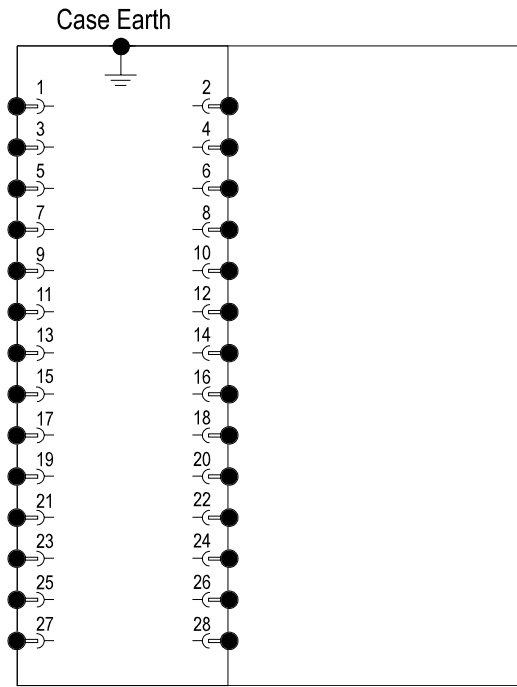

4M28 Case terminations (REAR VIEW)

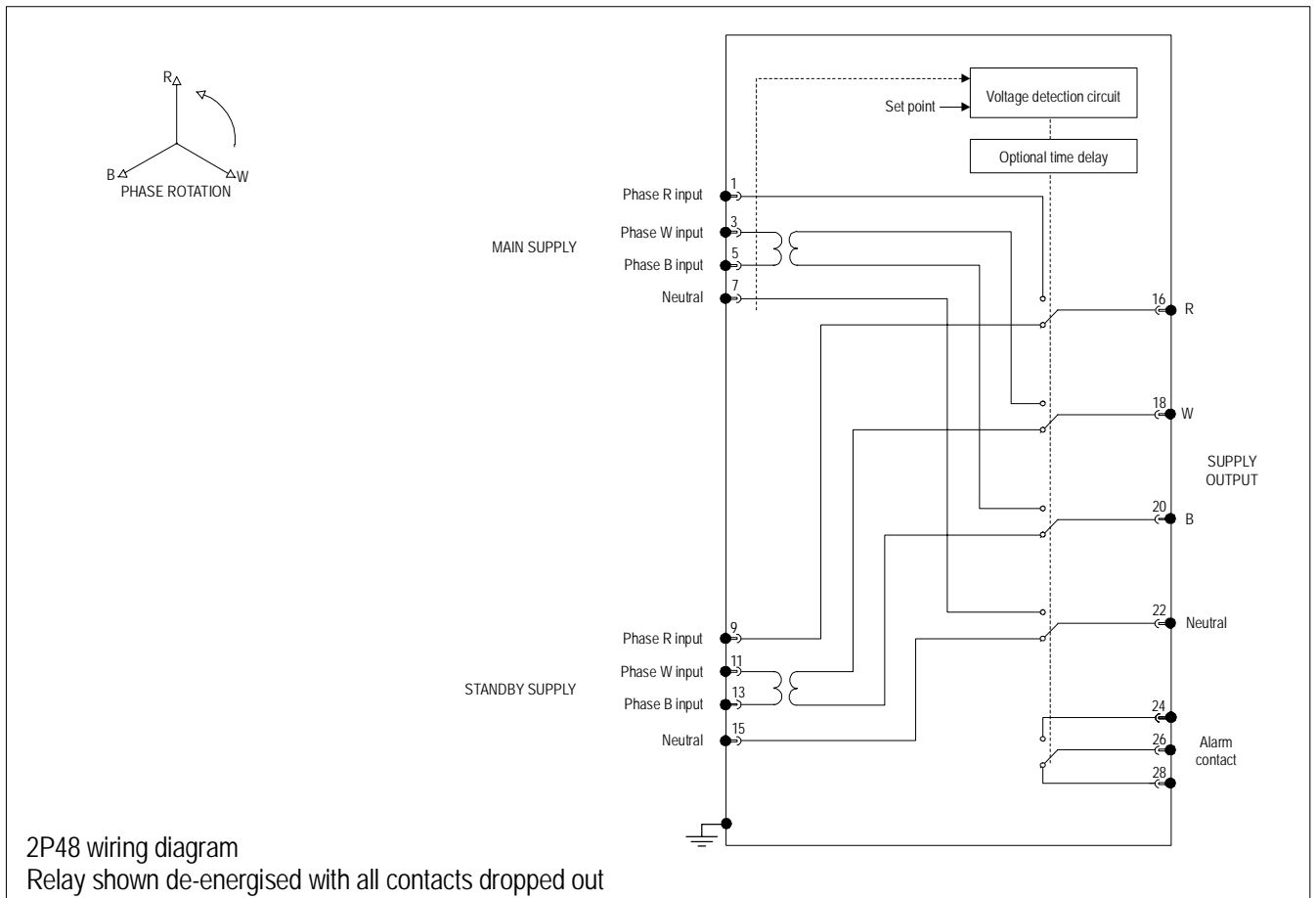

Australian Content

Unless otherwise stated the product(s) quoted are manufactured by RMS at our production facility in Melbourne Australia. Approximately 60% of our sales volume is derived from equipment manufactured in house with a local content close to 90%. Imported components such as semi-conductors are sourced from local suppliers & preference is given for reasonable stock holding to support our build requirements.

Quality Assurance

RMS holds NCSI (NATA Certification Services International), registration number 6869 for the certification of a quality assurance system to AS/NZS ISO9001-2000. Quality plans for all products involve 100% inspection and testing carried out before despatch. Further details on specific test plans, quality policy & procedures may be found in section A4 of the RMS product catalogue.

Product Packaging

Protection relays are supplied in secure individual packing cardboard boxes with moulded styrene inserts suitable for recycling. Each product & packing box is labeled with the product part number, customer name & order details.

Design References

The products & components produced by RMS are based on many years of field experience since Relays Pty Ltd was formed in 1955. A large population of equipment is in service throughout Australia, New Zealand, South Africa & South East Asia attesting to this fact. Specific product & customer reference sites may be provided on application.

Product Warranty

All utility grade protection & auxiliary relay products, unless otherwise stated, are warranted for a period of 24 months from shipment for materials & labour on a return to factory basis. Repair of products damaged through poor application or circumstances outside the product ratings will be carried out at the customer's expense.

Standard Conditions of Sale

Unless otherwise agreed RMS Standard Terms & Conditions (QF 907) shall apply to all sales. These are available on request or from our web site.



Relay Monitoring Systems Pty Ltd

6 Anzed Court, Mulgrave, Victoria 3170, AUSTRALIA

Tel: 61 3 9561 0266 Fax: 61 3 9561 0277 Email: rms@rmspl.com.au Web: www.rmspl.com.au