

Features

SYSTEM FEATURES

- Large back lit display panel
- System status LED indicators
- Simple menu setting procedure
- Wide auxiliary supply range with fail alarm contact
- Self diagnosis & fail alarm
- Size 4M56-S draw out case
- Made in Australia

CONTROL FEATURES

- Synchronism Check (25)
- Adjustable phase angle and time delay
- Flexible Live and Dead Voltage configuration
- Bus or Line U/V Close Block
- Voltage Differential Close Block
- Frequency Slip Close Block
- Flexible Synchronism Check Bypass Logic
- Manual Safe to Close Feature

METERING

- Line & Bus voltage display
- Relative phase angle display
- Line & Bus frequency display
- Frequency slip display

COMMUNICATION

- USB front programming port
- Non platform specific PC programming software: μ MATRIXwin
- Optically isolated RS485 network communication port
- MODBUS RTU compatible network protocol

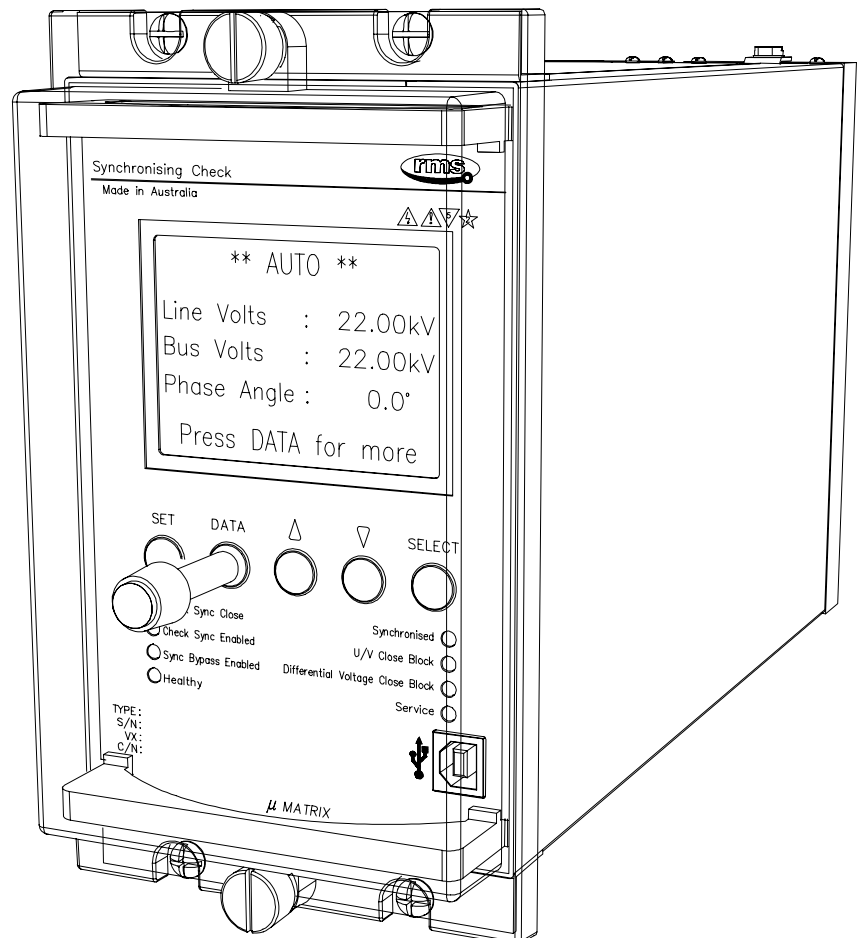

2SY212-S depicted in a 4M56-S draw out case

Description

Made in Australia

The 2SY212 synchronism check relay is designed to measure the phase angle between the monitored single phase voltages on the line & bus sides of a circuit breaker & verify that this angle is less than setting. If the measured angle has met this criteria for the time period defined by the setting & the voltage magnitudes meet the criteria established by the Live Line/Bus & U/V Line/Bus settings, the output relay will be energised & the breaker permitted to close. Resetting will occur if either the phase angle or voltage magnitude stray outside the pre-set limits or if the sync check enable input is de-energised. Front panel LED's provide visual indication of relay status & sync check function.

Bus or Line U/V, Differential Voltage and Frequency Slip Close block functionality together with flexible synchronism check bypass logic caters for a diverse range of applications.

Hardware Platform

The 2SY212 relay is built on the Micro MATRIX digital platform. The standard Micro MATRIX human machine interface (HMI) is combined with fully solid-state voltage sensing & measuring circuitry to provide high accuracy, simple set up & flexible operation. Self-monitoring is carried out by hardware & software watchdogs. A CPU software watchdog records abnormal events & performs automatic periodic checks. High speed, high contact rating output relays are used.

FRONT PANEL STATUS INDICATION

- | | |
|----------------------------------|-----------|
| Check Sync Close | Red LED |
| Synchronised | Red LED |
| Check Sync Enabled | Red LED |
| U/V Close Block | Red LED |
| Sync Bypass Enabled | Red LED |
| Differential Voltage Close Block | Red LED |
| Healthy | Green LED |
| Service | Red LED |

Application

Check Synchronising is required whenever two parts of a power system network, each containing generation, have to be connected or re-connected together as depicted in figure 1:

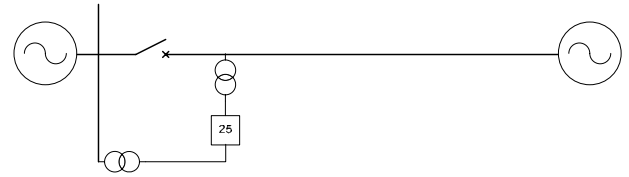

Figure 1

The primary application of the 2SY212 is in situations that require verification that synchronism exists prior to closing a circuit breaker to bring a generator on line or re-establish an interconnection between two parts of a power system.

The 2SY212 Series are designed to ensure the two systems are within preset limits of phase angle & voltage prior to circuit breaker closure.

To avoid undesired system disturbances, shock loading and possible damage to primary electrical plant the voltage, frequency and phase angle difference between the two systems should be within acceptable limits relative to one another before the connection point circuit breaker is closed.

If a circuit breaker can be a paralleling point between two generation sources, it is common practice to automatically perform a check to ensure the sources are within allowable voltage limits before permitting closure of the circuit breaker.

Synchronism check relays check that the bus and line input voltages are within defined differential limits of voltage magnitude, phase angle and frequency. The check is performed before either manual close or automatic reclose signals can close the circuit breaker. Figure 2

The synchronism check feature may also be utilised as the means of detecting undesired generator island conditions and in turn blocking the closure of the interface circuit Breaker between an embedded generator and the main transmission or distribution network. In such applications the synchronism check feature is not being utilised for the purpose of allowing synchronisation of an islanded generator, but rather preventing it.

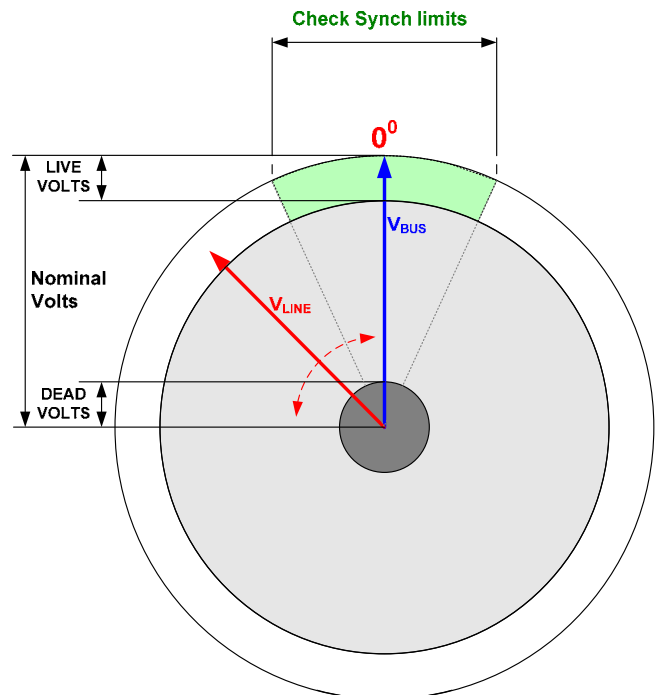

Figure 2

LIVE & DEAD VOLTAGE LEVEL ELEMENTS

The Voltage elements determine the status of the line and bus voltage. If the voltages on either the line or bus are below a set threshold level they can be considered to be 'dead'. If the voltages are within a setting band around the nominal they are classed as 'live'. Figure 3 Independent voltage level elements are provided for both line and bus voltage inputs.

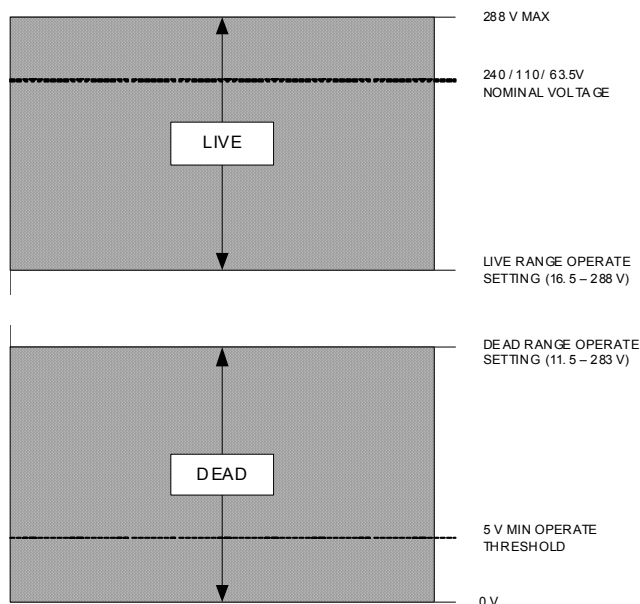

Figure 3

Note: the area between the dead and live zones is & considered neither LIVE or DEAD. CB closure in this intermediate zone is blocked.

- Dead Line: 11.5 to 283 V in 0.5V steps
- Dead Bus: 11.5 to 283 V in 0.5V steps
- Live Line : 16.5 to 288 V in 0.5V steps
- Live Bus : 16.5 to 288 V in 0.5V steps

It is recommended that a minimum hysteresis gap of 5V be maintained between the Dead range operate and the Live range operate setting.

SYNCHRONISM CHECK ELEMENTS

For the relay to issue a Synchronism Check close output the following conditions are to be met:

SYNCHRONISM CHECK PHASE ANGLE

Defines the allowable phase difference between the line and bus voltages for a valid close signal. Whilst within the defined limits the phase angle can be either increasing or decreasing for a valid close signal to be issued.

Setting: 5 to 90 deg in 1 deg steps

SYNCHRONISM CHECK SLIP TIMER

If enabled this defines the duration in which the synchronism conditions of phase angle and voltage must be met for a valid close signal to be issued. If either the phase angle or voltage fall outside of their limits the slip timer is reset and valid phase angle and voltage conditions must be met for the full slip timer duration for a valid close signal to be issued.

Setting: 0.1 to 100 sec in 0.1 sec steps

SYNCHRONISM CHECK SLIP FREQUENCY

If enabled this defines the maximum frequency difference between the bus and line voltage for a valid close signal to be issued.

Setting: 0.05 to 2.00 Hz in 0.01 Hz steps

LINE U/V DETECTOR

If enabled this defines the line voltage below which a valid close signal will be blocked.

Setting: 22 to 288 V in 0.5 V steps

Note : regardless of the U/V Detector setting the available voltage must be above 5V for the Synchronism Check algorithms to make a valid close signal decision. Under these operating conditions the Synchronism Check Bypass logic may still provide a valid close signal, refer to Synchronism Check Bypass Logic.

BUS U/V DETECTOR

If enabled this defines the bus voltage below which a valid close signal will be blocked.

Setting: 22 to 288 V in 0.5 V steps

Note : regardless of the U/V Detector setting the available voltage must be above 5V for the Synchronism Check algorithms to make a valid close signal decision. Under these operating conditions the Synchronism Check Bypass logic may still provide a valid close signal, refer to Synchronism Check Bypass Logic.

DIFFERENTIAL VOLTAGE DETECTOR

If enabled this defines the maximum scalar voltage differential between the bus and line voltage for a valid close signal to be issued.

Setting: 2 to 44 V in 0.5 V steps

SYNCHRONISM CHECK INITIATE MODE

The Check Synchronising operation of the relay is initiated in two different modes.

These modes are settable as 'Check Sync Enable'
Setting parameters : AUTO and MANUAL

AUTO: The relay will issue a Check Sync Close output automatically if the relevant conditions mentioned above are met.

MANUAL: The relay will only issue a Check Sync Close output if the relevant conditions are met AND if it has received a command to do so. This command is issued via the Start Check Sync status input. (See also Close Guard Feature).

Note: The Check Sync Close output relay will stay on for a minimum time of 100ms and for the whole duration of the time that the system parameters are met.

The synchronism check logic is shown in figure 4.

CLOSE GUARD FEATURE

If manual closes are required to be carried out via an operator, the 'Close Guard' feature can be enabled which prevents the operator from initiating a CB close before the relay issues a valid Check Sync Close signal. This prevents the operator from pre-empting the relays' decision.

Setting: OFF or ON

When active and the operator is trying to pre-empt the relay the LCD will display the following message:

CLOSE GUARD ACTIVE

SYNCHRONISM CHECK BYPASS LOGIC

For switching operations, which involve connecting an uncharged line or bus to a live line or live bus, a means of bypassing the synchronising operation is required.

This is achieved by using synchronism bypass logic.

When the synchronism bypass logic is enabled the available combinations of bypass conditions are :

- Dead Line AND Live Bus: (DL & LB) or
- Live Line AND Dead Bus: (LL & DB) or
- Dead Line AND Dead Bus: (DL & DB)

To bypass the synchronisation feature and issue a Bypass Close output at least one of the selected line and bus conditions have to be met and the Sync Bypass status input has to be energised.

The Bypass Close output will stay on for the duration of the status input energisation & while the line and bus conditions are met.

The synchronism check bypass logic is depicted in figure 5.

RELAY DISPLAY ALARMS

The following alarms are displayed on the relay LCD screen:

- MANUAL CLOSE PERMITTED
- CLOSE GUARD ACTIVE

This provides feedback to the operator to indicate that manual closure of the circuit breaker is permitted as either the synchronism check conditions or the synchronism check bypass conditions have been met.

RELAY RESET

The relay reset pushbutton shall clear all Alarm conditions displayed on the LCD screen and reset latched LEDs.

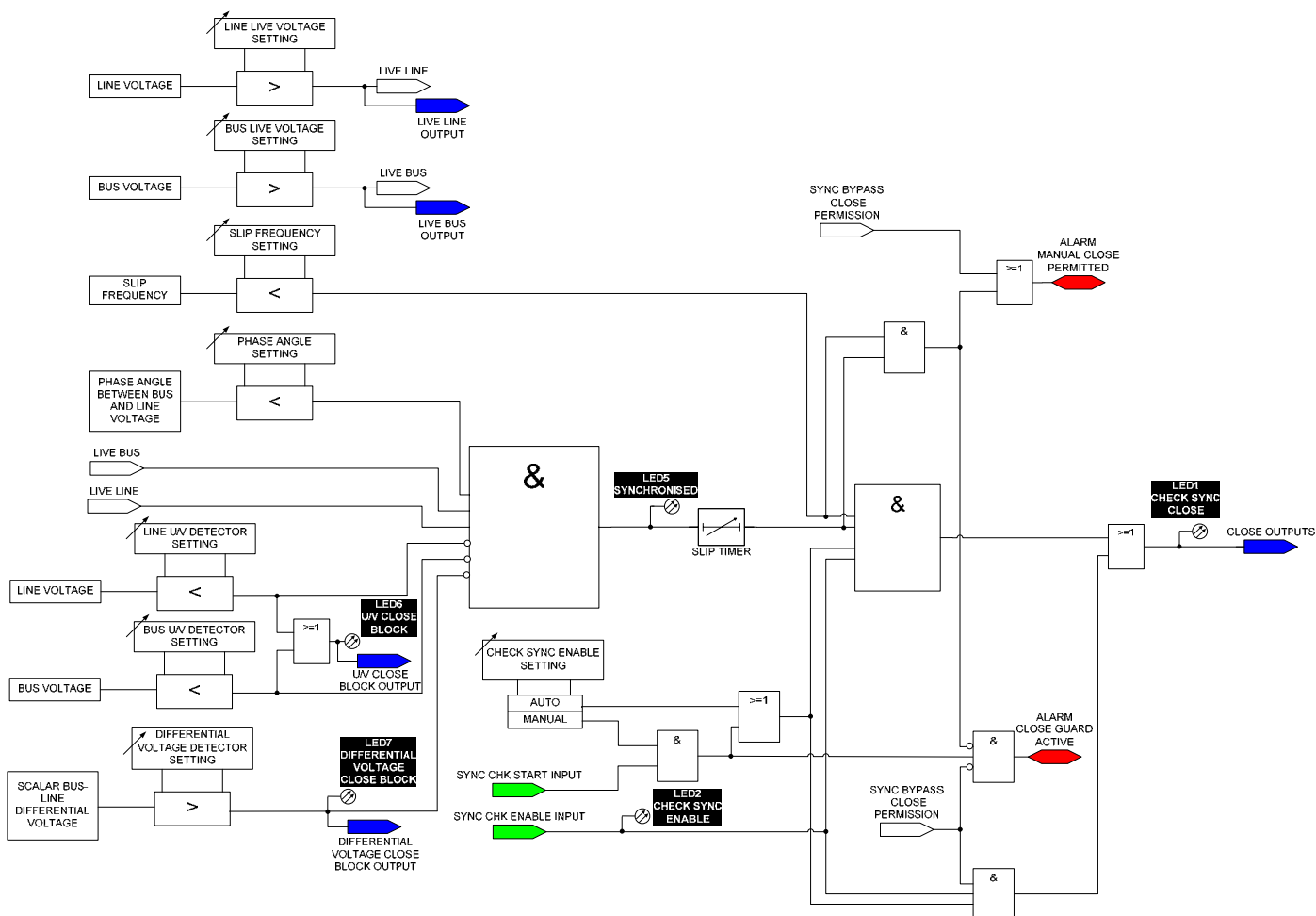

Figure 4 - Synchronism check logic diagram

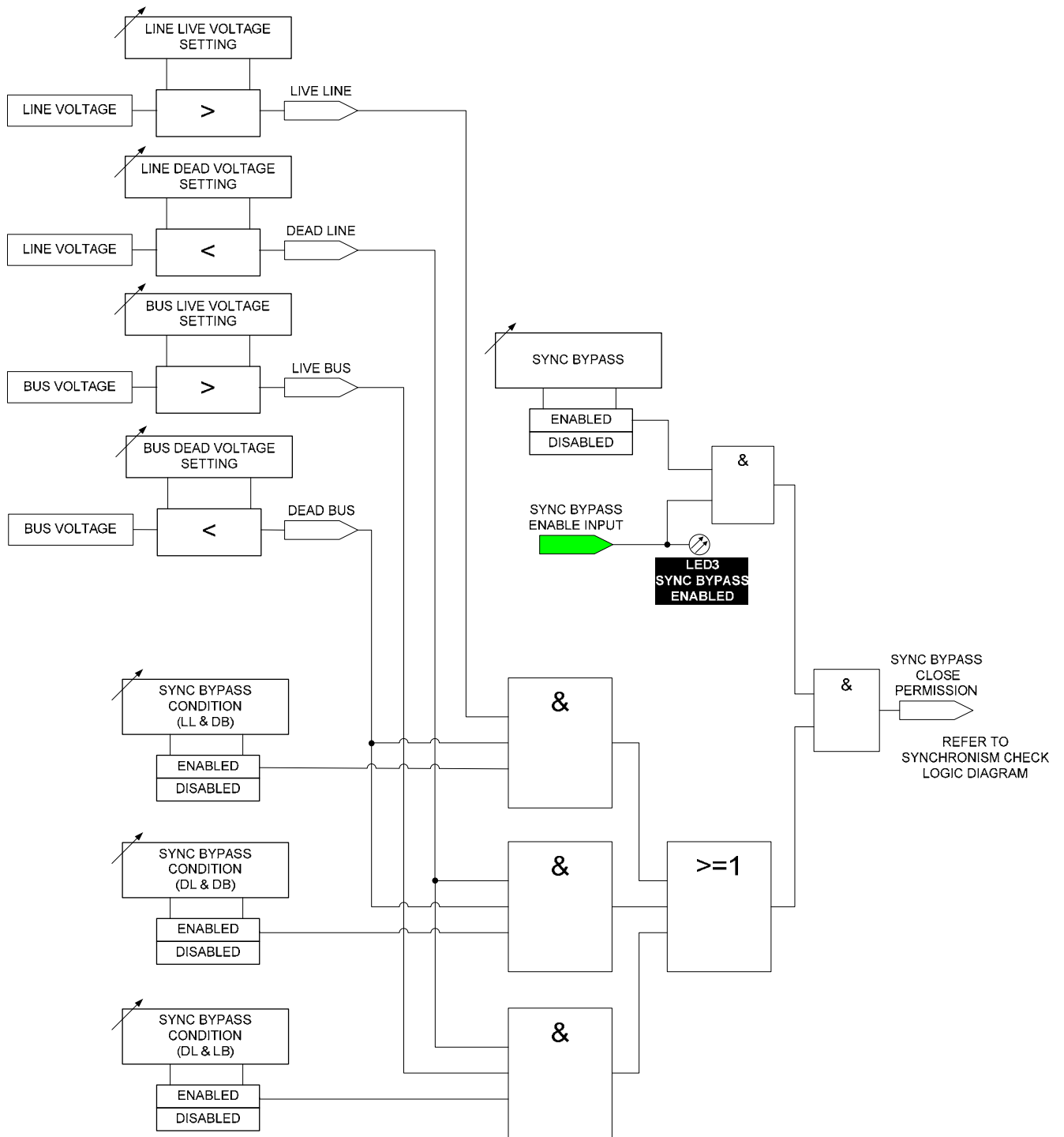

Figure 5 - Synchronism check bypass logic diagram

Figures 6 to 9 provide examples of typical synchronism check scheme wiring configurations.

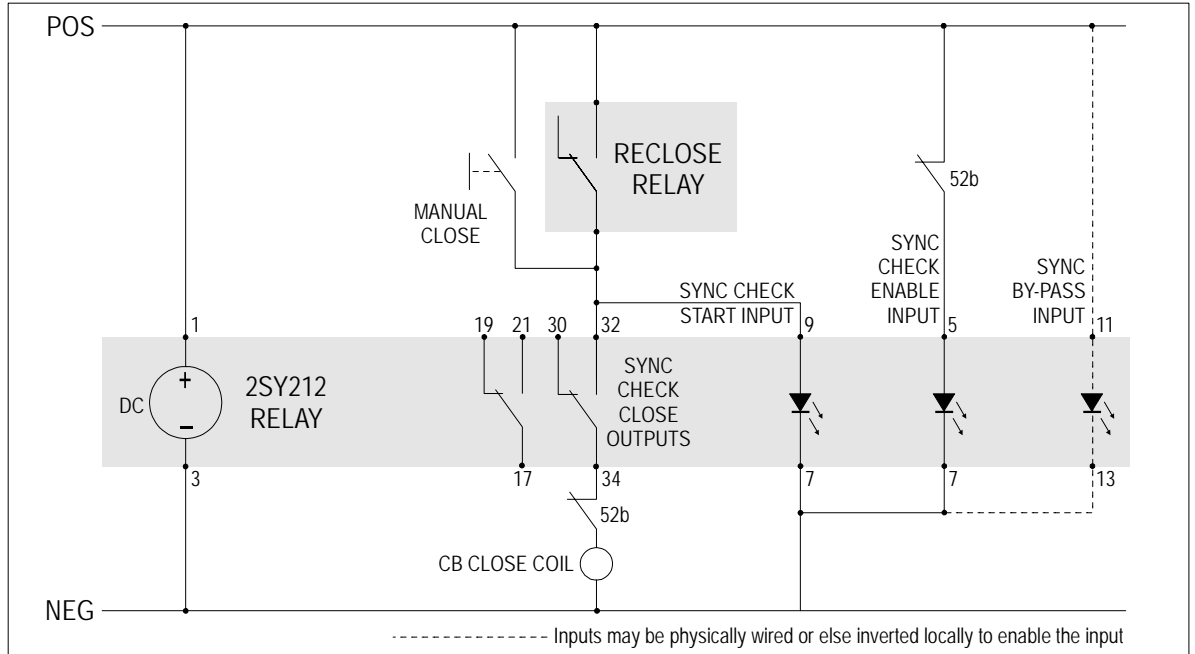

Figure 6 – 2SY212 relay connected in sync check start mode

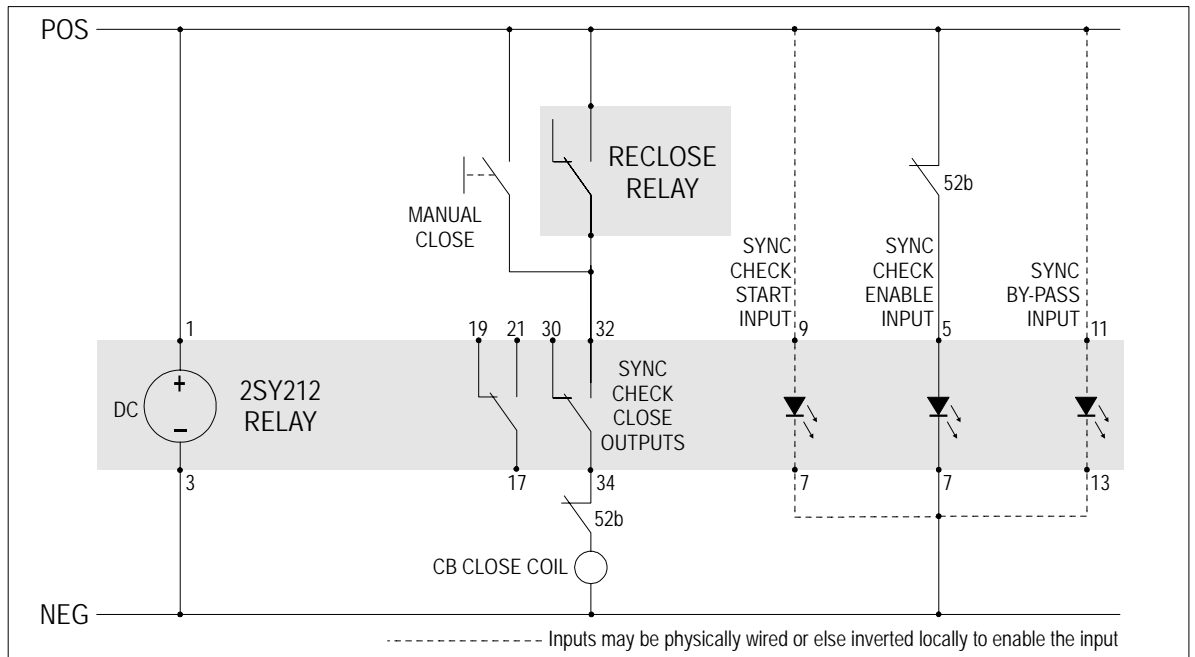

Figure 7 – 2SY212 relay connected in monitoring mode

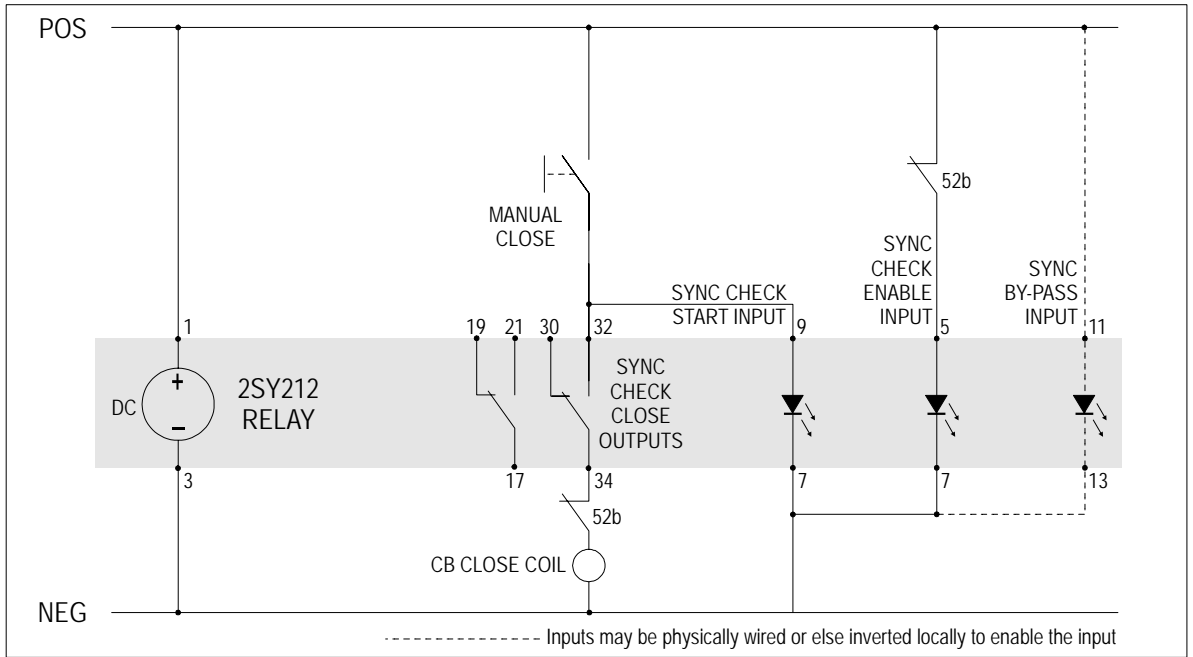

Figure 8 – 2SY212 relay connected in synchronism check start mode

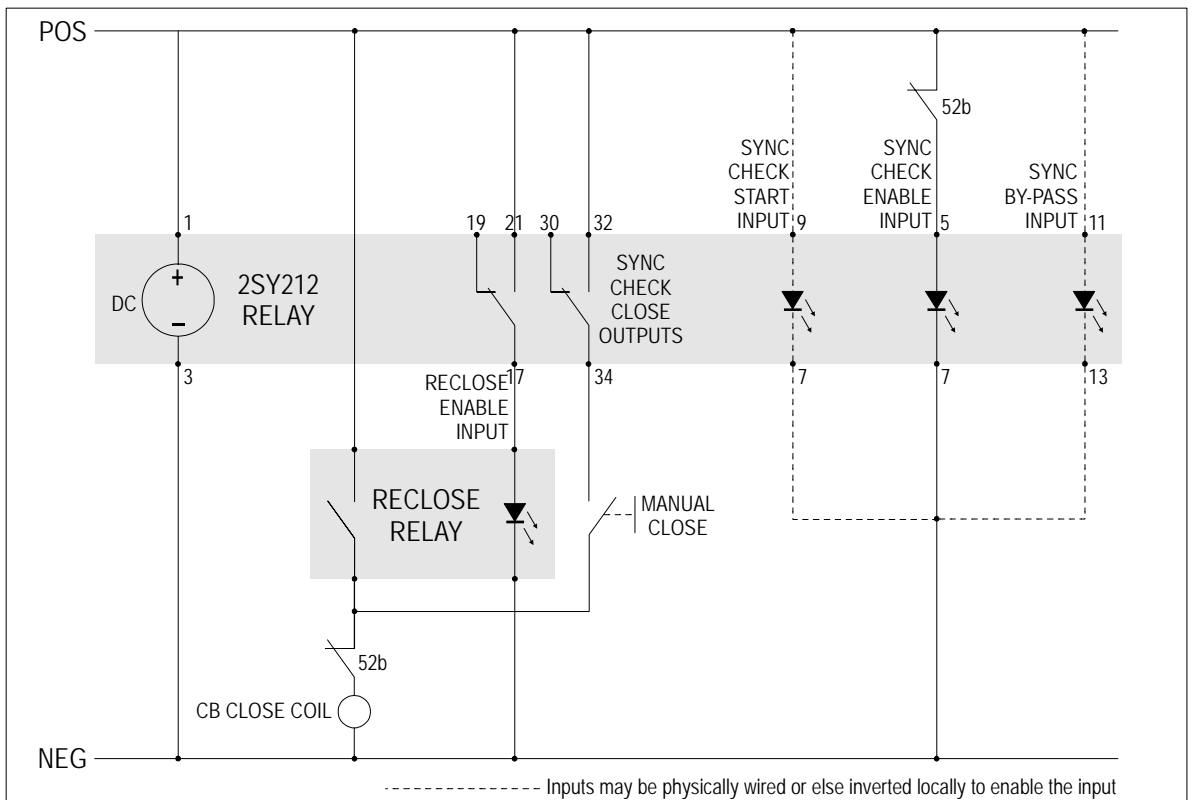

Figure 9 – Alternative arrangement for the 2SY212 relay connected in monitoring mode and initiating auto reclose

SENSING INPUT

BUS VT sensing inputs: Single phase 63.5 & 110V AC
 Line VT sensing inputs: Single phase 63.5 & 110V AC
 Sensing supply burden: Less than 0.2VA
 Thermal rating: 300V continuous

VOLTAGE MEASUREMENT ACCURACY

Precision of setting: 0.1V steps
 Pick up repeatability: +/-0.15V from 90 to 120V
 Voltage display: 4 digits from 10 to 145V
 Resolution of display: 0.1V
 Accuracy of display: +/-0.15V

Table 1 describes the accuracy for the following parameters:

- Live operate
- Dead operate
- Undervoltage
- Differential voltage

Range	Accuracy	Resolution
63.5v	+/-0.09V	+/-0.06V
110v	+/-0.15V	+/-0.10V
240v	+/-0.33V	+/-0.22V

Table 1

FREQUENCY MEASUREMENT ACCURACY

Frequency measurement: +/-0.03Hz

FREQUENCY SLIP ACCURACY

Frequency slip display resolution: +/-0.01Hz
 Operate: Setting +/-0.03Hz

PHASE ANGLE MEASUREMENT ACCURACY

Phase angle display resolution: +/-0.1deg
 Operate: Setting +/-1deg

SYNCHRONISM CHECK SLIP TIMER ACCURACY

Synch check slip timer: +/-20ms

STATUS INPUTS

The status inputs on the 2SY212 is used to enable:

- Synchronism check enable
- Synchronism check start
- Synchronism check bypass logic

STATUS INPUT FUNCTION

The status input function is factory set for the relay to be enabled on the application of a control voltage. It is also possible for the status input to operate on the removal of a control voltage by simply changing a software flag in the PC setup program.

STATUS INPUT MINIMUM OPERATING CURRENT

10 mA P/U for 1 ms then reducing to 1.5 mA after 4 ms.

STATUS INPUT OPERATING TIME

Initiate input	Parameter	Delay
DC	P/U	<4 ms
	D/O	<16 ms
AC	P/U	<23 ms
	D/O	<33 ms

Table 2

RELAY FAIL ALARM

A C/O alarm contact is maintained in the energized state when all of the following conditions are met:

- The auxiliary supply is applied
- The internal 24V DC rail is within acceptable limits
- The CPU hardware watchdog maintains a pulsing output

A CPU software watchdog records "suspect" events to an assert register and if necessary performs a soft restart.

AUXILIARY SUPPLY

20-70V DC switchmode supply or
 40-275V AC / 40-300V DC switchmode supply
 Burden: Less than 7 watts during timing

Inputs:

A high efficiency switchmode power supply is incorporated which provides a low burden to the auxiliary supply.

Input Transients:

Withstands multiple high-energy transients & ring waves in accordance with IEEE28 - ANSI C26.1 Cat. II, accordingly:

- 0.5uS 100kHz 6kV O/C, 500A S/C, 4J
- 1.2/50uS 6kV O/C
- 8/20uS 3kA S/C, 80J clamped at 1,000V

Mains conducted EMI within limits specified by AS 3548 Class B.

Isolation:

The inputs are isolated from the outputs in accordance with AS3260 Class II Limited Current Circuitry, accordingly:

- Withstand voltage of 2.5kV RMS 50Hz for one minute
- Creepage & clearance distance greater than 4mm
- Output leakage current less than 0.25A to earth

Output Protection:

Outputs will withstand continuous short circuit. Output regulators & switching control regulator are thermally protected.

OUTPUT CONTACTS

2 C/O self reset: Synchronise check close output
 1 C/O self reset: Live line output
 1 C/O self reset: Live BUS output
 1 C/O self reset: Undervoltage close block output
 1 C/O self reset: Differential voltage close block
 1 C/C self reset: Power supply fail / CPU watchdog alarm

OUTPUT CONTACT RATINGS

IEC60255-0-2

Carry continuously 5A AC or DC
 Make & carry 0.5 s 20 A AC or DC
 L/R ≤ 40ms & V ≤ 300V 0.2 s 30 A AC or DC
 AC resistive 1,250 VA
 Break capacity 250 VA @ PF ≤ 0.4
 I ≤ 5A & V ≤ 300V DC resistive 75 W
 DC inductive 30 W @ L/R ≤ 40 ms
 50 W @ L/R ≤ 10 ms
 10⁶ at maximum load
 Minimum number of operations 0.5W limit 10mA / 5 V
 Minimum recommended load

TRANSIENT OVERVOLTAGE

IEC60255-5 CLASS III

Between all terminals & earth 5 kV 1.2/50 us 0.5 J
 Between independent circuits without damage or flashover 5 kV 1.2/50 us 0.5 J

INSULATION COORDINATION

IEC60255-5 CLASS III

Between all terminals & earth 2.0 kV rms for 1 min.
 Between independent circuits 2.0 kV rms for 1 min.
 Across normally open contacts 1.0 kV rms for 1 min.

AUXILIARY SUPPLY

IEC60255-11

Allowable breaks / dips in supply ≤ 20 ms
 Collapse to zero from nominal voltage

HIGH FREQUENCY DISTURBANCE

IEC60255-22-1 CLASS III

2.5 kV 1MHz common mode ≤ 3% variation
 1.0 kV 1MHz differential mode

ELECTROSTATIC DISCHARGE

IEC60255-22-2 CLASS III

6 kV contact discharge ≤ 5% variation

FAST TRANSIENT

IEC60255-22-4

4 kV, 5/50 ns, 100 KHz repetitive ≤ 3% variation

TEMPERATURE RANGE

Operating: -5 to +55°C
 Storage: -25 to +75°C

HUMIDITY

IEC68-2-1/2

40 °C & 95% RH non condensing

RELAY CONFIGURATION USING μ MATRIXwin

The purpose of the μ MATRIXwin application is to provide display, configuration and diagnostic facilities required to support the entire family of μ MATRIX digital relays. The prime functions of the application are:

Create a setting file off line

To create & view relay setting files at your PC without the need for a relay;

Relay setting

To download a setting file (UMP) into a relay connected to a PC;

To display & change settings in a connected relay;

Relay status

To display the Status of nominated inputs and outputs of a connected relay;

Commissioning

To export reports of setting parameters & status screen to confirm correct functionality during commissioning;

Upgrade relay software

To configure a μ MATRIX relay for a specific customer application;

To upgrade the operational software (UMX) of a μ MATRIX relay;

All current UMX software applications may be downloaded from:

www.rmspl.com.au/umatrix

Maintenance

To provide utility and diagnostic facilities at a technical level.

ACCESSORIES SUPPLIED

- 1 x M4 self threading mounting screw kit P/N 290-406-151
- 2 x M4 terminal screw kit (28 per kit) P/N 290-407-153
- 1 x μ MATRIX User Guide per order

CASE

- 4M56-S Size 4 draw out with 56 M4 screw terminals
- Mounting Flush panel or 4U high 1/4 width 19 inch rack mount
- 1 x CD - μ MATRIXwin software, setting files & applications per order

COMMUNICATION PORTS

Two (2) communications ports are available. The front USB programming port is provided as standard while the rear RS485 network port is available as an option.

Programming port

The programming port is accessible from the front panel of the relay via a USB physical link & PC configuration program supplied with the relay. The μ MATRIXwin configuration program is designed to operate with all relays from the μ MATRIX range & with all installed firmware version.

Network port

The network port is intended for applications where permanent connection to a master control system is required. An optically isolated RS485 physical layer is provided for this function.

The RS485 connection is intended for applications where multiple μ MATRIX relays are to be connected on a common communications bus.

Network Port Terminating Resistor

Where multiple relays are connected in a multi-drop configuration the RS485 comms. bus must have a 120 ohm terminating resistor fitted at each end. If the μ MATRIX-S relay is at one end of the transmission line a terminating resistor can be added by placing SW100-3 and SW100-4 in the ON position as depicted in the wiring diagram.

Network Port BIAS Resistors

Where a single relay is connected to the network, or where the relay is a long distance from other devices on the comms. bus, BIAS resistors may need to be fitted to ensure reliable operation. To simplify this configuration, BIAS resistors are fitted to each μ MATRIX-S relay and may be selected IN by setting switches SW100-1 and SW100-2 to the ON position as depicted in the wiring diagram. This bank of four switches can be accessed by withdrawing the relay module from its case, turning upside down and looking at the centre PCB near the rear terminal blocks.

PC TO μ MATRIX USB CONNECTION

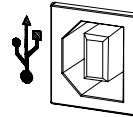

2V164-S front panel USB programming port

USB DRIVERS

The μ MATRIX-S USB port is configured as a Virtual Communications Port (VCP) & is operated through a PC COM port. USB drivers must be installed on the PC to enable correct communication. A ZIP file containing the driver files needed for this process may be downloaded from:

www.rmspl.com.au/umatrix

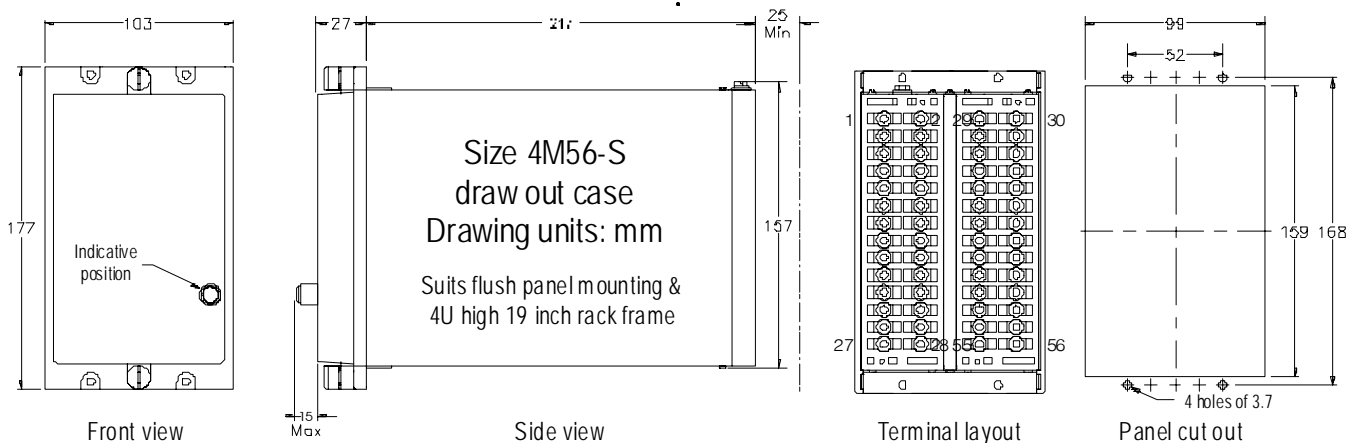

Ordering Information

Generate the required ordering code as follows:
e.g. 2SY212-S-BAAA

General Type	Order Code			
2SY212-S	1	2	3	4

- 1 AUXILIARY SUPPLY RANGE**
A 20-70V DC B 40-275V AC (300V DC)
- 2 DIGITAL INPUT OPERATING VOLTAGE – GROUP 1**
A 24-80V AC/DC B 80-150V AC/DC
C 150-275V AC (300V DC) D 18-275V AC (300V DC)
- 3 DIGITAL INPUT OPERATING VOLTAGE – GROUP 2**
A 24-80V AC/DC B 80-150V AC/DC
C 150-275V AC (300V DC) D 18-275V AC (300V DC)
- 4 REAR COMMUNICATIONS PORT**
A Not required
B Required – Modbus protocol

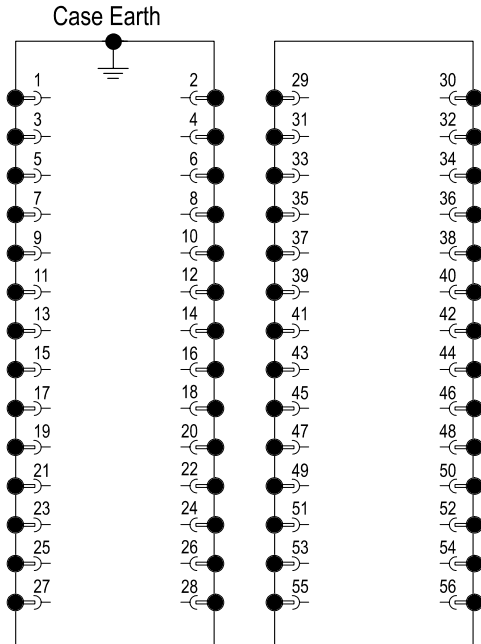

4M56 Case terminations (REAR VIEW)

*Note: The status inputs & some relay outputs are assigned by the software (UMX) loaded on the relay.

Shown here are the standard assignments of the A UMX. Other UMX versions may differ. Consult the UMX data sheets for specific I/O assignments.

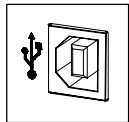

FRONT PANEL USB PROGRAMMING PORT

SCADA COMMUNICATIONS PORT RS485 Network port



To other μ MATRIX relays (Up to 32 units)
Invoke terminating 120R resistor to end of BUS relay only.
To do this set SW100-3&4 ON.

Invoke BIAS resistors for single relay connection only.
To do this set SW100-1&2 ON.

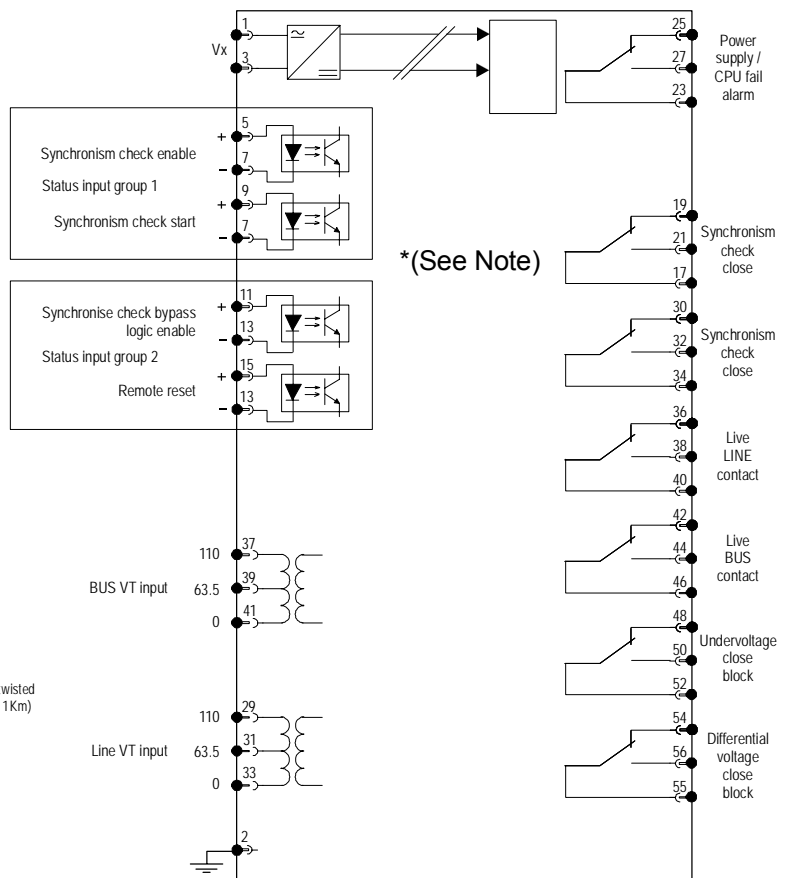

*(See Note)

2SY212-S wiring diagram - Relay shown in de-energised condition

Australian Content

Unless otherwise stated the product(s) quoted are manufactured by RMS at our production facility in Melbourne Australia. Approximately 60% of our sales volume is derived from equipment manufactured in house with a local content close to 90%. Imported components such as semi-conductors are sourced from local suppliers & preference is given for reasonable stock holding to support our build requirements.

Quality Assurance

RMS holds NCSI (NATA Certification Services International), registration number 6869 for the certification of a quality assurance system to AS/NZS ISO9001-2008. Quality plans for all products involve 100% inspection and testing carried out before despatch. Further details on specific test plans, quality policy & procedures may be found in section A4 of the RMS product catalogue.

Product Packaging

Protection relays are supplied in secure individual packing cardboard boxes with moulded styrene inserts suitable for recycling. Each product & packing box is labeled with the product part number, customer name & order details.

Design References

The products & components produced by RMS are based on many years of field experience since Relays Pty Ltd was formed in 1955. A large population of equipment is in service throughout Australia, New Zealand, South Africa & South East Asia attesting to this fact. Specific product & customer reference sites may be provided on application.

Product Warranty

All utility grade protection & auxiliary relay products, unless otherwise stated, are warranted for a period of 24 months from shipment for materials & labour on a return to factory basis. Repair of products damaged through poor application or circumstances outside the product ratings will be carried out at the customer's expense.

Standard Conditions of Sale

Unless otherwise agreed RMS Standard Terms & Conditions (QF 907) shall apply to all sales. These are available on request or from our web site.



Relay Monitoring Systems Pty Ltd

6 Anzed Court, Mulgrave, Victoria 3170, AUSTRALIA

Tel: +61 3 8544 1200 Fax: +61 3 8544 1201 Email: rms@rmspl.com.au Web: www.rmspl.com.au