

Features

- Switchmode power supply enables the relay to operate from a wide range of auxiliary supply voltages (40 to 275V AC / 40 to 300V DC), or alternatively directly from the monitored transformer voltage.
- Solid state circuitry (except the electromechanical output relays), providing low burden on the VT & CT.
- Over voltage alarm relay output may be used for fast tap function.
- Under voltage blocking with alarm relay. Tap-changer commands will be inhibited if the sensed voltage falls below customer set minimum.
- Initial time delay may be set from 20 to 260 seconds.
- Interval time delay may be set from 5 to 65 seconds.
- Inverse time delay characteristic may be selected for the initial time delay.
- Built in Line Drop Compensator with a tapped current transformer to cater for 1 & 5 Amp nominal sensing currents.
- LED's indicate system voltage deviation from the preset bandwidth & if output relays are energised.
- Front panel accessible test points are provided via a D connector, enabling in-service monitoring of all significant internal calibration voltages.
- Tap changer fail alarm. Output relay switches if tap changer fails to acknowledge a *RAISE/LOWER* command signal or if the monitored voltage does not return to the preset band width within a time limit of 300 seconds (Approx).
- Power supply fail relay drops out if the Auxiliary supply fails or transformer VT connection fails if this is used to power the relay.
- Optional case styles.
- Made in Australia.

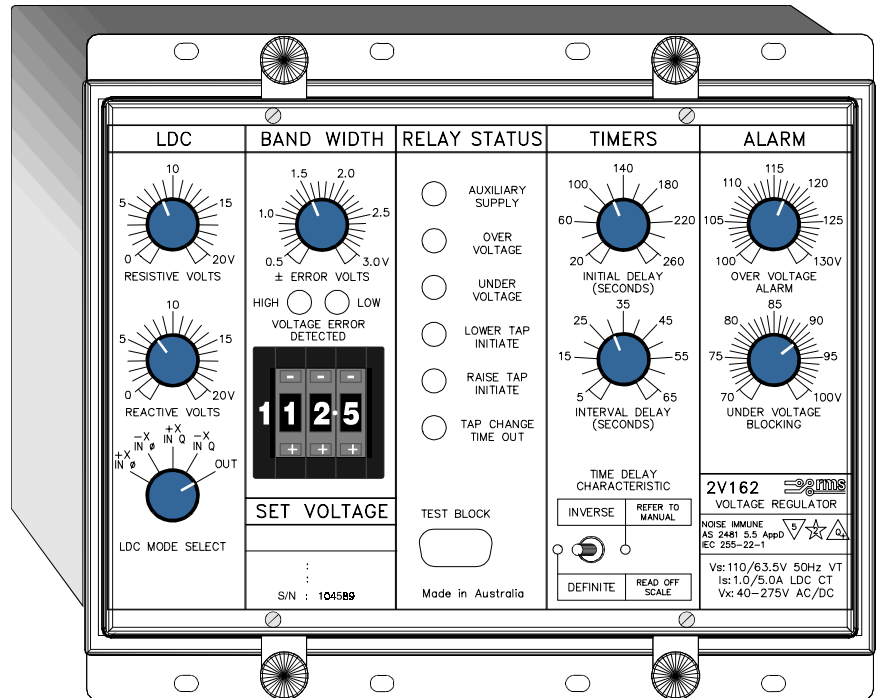

2V162 depicted in a size 8E rack mount case

Application

Made in Australia

The 2V162 Series relays are designed for the control of motor driven on-load power transformer tap changers. The 2V162 Voltage Regulator Relay continuously monitors the transformer output voltage & current & provides "RAISE" & "LOWER" control commands to the on-load tap changer such that the load centre is automatically maintained within acceptable limits. Small variations in supply frequency will not affect the system performance.

When designing the 2V162, considerable emphasis was placed on producing a relay which would be very simple to install, set up & operate in the field. The result is a simple yet effective & very dependable voltage regulator relay available at a competitive price. The relay is very easy to set up due to the individual controls laid out in functional groups on the front panel.

Some models may also be specified with special adaptor kits to enable the retrofitting of AVE electromechanical relays. Refer to the Mounting Adaptors section for details.

RMS 2V162 Relays have many in built features to simplify the interface with OLTC's to provide a reliable, effective & simple to operate voltage control system.

Operation

Australian designed & manufactured, the 2V162 Series AVR's have been proven in the field for over 10 years throughout Australia, New Zealand & SE Asia.

A feature of our manufacturing program is our ability to configure to order on a short lead time basis.

This brochure details the technical parameters for the wide range of standard models & options now available. Our engineering facilities also cater for custom requirements & are able to modify these catalogue items to meet specific design needs.

Relay Setting



SET VOLTAGE RANGE

Thumb wheel switch selection:

100 to 129.5V for 110 V nominal input with 0.5 V setting resolution.

Remote voltage push button selection:

80 to 129V for 110V nominal input with one volt setting resolution.

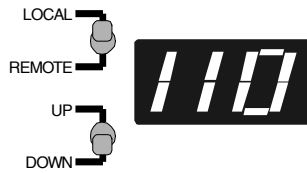

Toggle voltage setting and non-volatile LED display

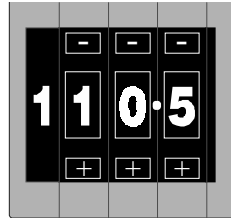

Thumbwheel voltage setting switches

SET VOLTAGE HYSTERESIS

50% of error voltage (Other values may be specified)

VOLTAGE BANDWIDTH SETTING (SENSITIVITY)

+/-0.5% to +/-3% of nominal 110 Volts. (Continuously adjustable).

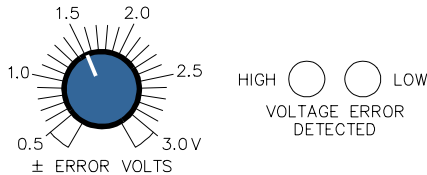

The bandwidth setting should be made in accordance with the relative step voltage of the tap changer. A narrow bandwidth may result in the tap changer *hunting* between adjacent taps.

LINE DROP COMPENSATION

The range of both resistance & reactance compensation is 0% to 15% (continuously adjustable) of nominal monitored voltage. A switch is provided to cater for *in phase* & *in quad* connections, with either positive or negative reactance compensation.

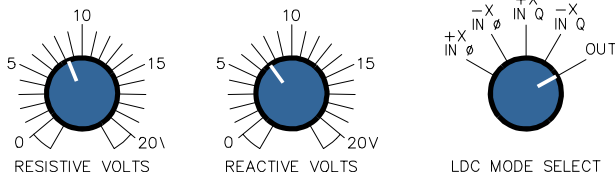

Correct setting of the LDC requires the calculation of the resistive & reactive line-drops as a percentage of nominal with reference to the secondary side of the VT & the setting of the instrument transformer for IN PHASE or IN QUAD connection.

OPERATIONAL INDICATORS

Light emitting diodes (LED's) indicate the following conditions

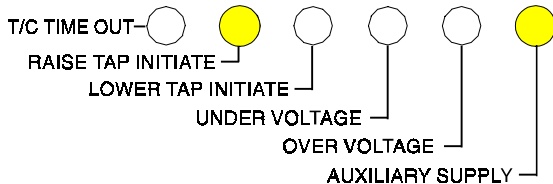

INITIAL RAISE / LOWER TIMER

The initial time delay between detection of an error in the monitored voltage, to resultant tap change output, is switch selectable as either a definite time or true inverse time response. In the definite time mode, the time delay may be read directly from the calibrated scale.

The initial time delay starts when the voltage deviation exceeds the upper or lower limit of the set bandwidth. The respective instantaneous HIGH / LOWER LED illuminates.

If the deviation falls back to within bandwidth limits before the pre set time delay is completed, the timer is reset.

At the completion of the pre set time delay the respective RAISE / LOWER tap output contact will close.



TIME DELAY CHARACTERISTIC

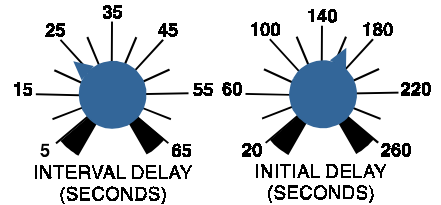

ACCURACY OF TIMERS

All timers +/-5% of full scale

INTERVAL TIME DELAY

The interval time delay only becomes active when the initial delay has caused a tap change but without effecting a balanced condition, i.e. if more that one tap change operation is necessary to bring back the voltage deviation within bandwidth limits.

The interval time delay is adjustable between 5 seconds (to allow almost continuous tap changing), & 65 seconds.

TIME DELAY CHARACTERISTIC SELECTION

In the inverse time mode, the initial time delay is inversely proportional to the ratio of deviation percentage/set bandwidth down to a minimum of one second delay. For example when the detected error is equal to the selected bandwidth the time delay may be read off the scale. For a detected error of N times the selected bandwidth, the time delay is 1/N times the delay setting.

UNDERVOLTAGE BLOCKING FUNCTION

The undervoltage blocking threshold can be set from 70% to 88% of nominal 110V continuously adjustable. Undervoltage blocking suppresses tap change operations during a system breakdown to avoid the tap changer mechanism from being driven to the top tap. An undervoltage alarm relay will also activate at the pre set voltage.

OVERVOLTAGE ALARM

The overvoltage blocking threshold can be set from 100% to 118% of nominal 110V continuously adjustable.

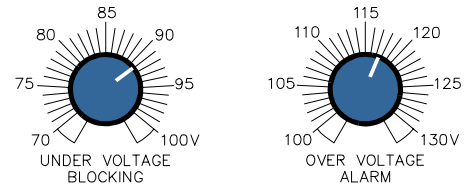

This function may be utilised to provide a fast tap down feature as soon as the pre set level is reached.

TEST POINTS

In service, testing is possible by means of a test socket to which the main electronic test points are connected. The test socket is accessible from the front panel.



Visit www.rmspl.com.au for the latest product information.

Due to RMS continuous product improvement policy this information is subject to change without notice. 2V162/Issue K/01/09/00/2/12

Specifications

VOLTAGE SENSING CIRCUITRY

Nominal monitoring voltage

110V 50HZ for IN QUAD connection & 63.5V 50HZ for IN PHASE connection to the voltage transformer (VT) input.

Sensing supply burden

Less than 1VA

Input resistance

63.5V tap: 227 Ohm
110V tap: 626 Ohm

Nominal sensing frequency

50Hz +/- 2Hz (60Hz version available)

Accuracy of voltage setting

+/- 0.5V at nominal 110V setting

Precision of voltage setting

0.5V for thumb wheel set versions
1.0V for remote voltage set versions

LINE DROP COMPENSATION (LDC) SENSING CIRCUITRY

Nominal sensing current

Standard LDC current transformer taps for 1A & 5A inputs

LDC CT burden

Less than 0.3VA

LDC current overload withstand

5 times nominal continuous, 100 Amps for 3 seconds (5A tap).

LDC accuracy

+/- 0.5V at nominal 110V setting

TAP CHANGE FAIL ALARM

In the event of a tap raise (or lower) command being sent by the 2V162 to the OLTC, the internal tap change fail timer is started and is only reset when the voltage deviation falls back to within bandwidth limits. In the event that the voltage deviation does not fall back within bandwidth limits within five (5) minutes the OLTC fail alarm is set.

TAP CHANGE FEEDBACK MECHANISM OPTIONS

VOLTAGE MONITORING (Automatic mode)

This option is available in the D & E Series case models only. When this mode is selected by the setting of internal jumpers in the VRR, the controlling raise (or lower) output relay contact to the OLTC operates after the elapsed time determined initially, by the setting of the Initial Raise/Lower timer, then repeated at a rate set by the Interval Timer setting. The output pulse is approximately 2 seconds in duration. This sequence is repeated until the voltage deviation falls back to within bandwidth limits. This mode does not require a hard wired contact between the OLTC and the VRR.

OLTC AUXILIARY CONTACT METHOD

Available on all models

In this mode a normally closed auxiliary contact on the OLTC is required. The contact must open for a one (1) second duration minimum during a tap change operation on the OLTC. This contact is wired back to the 2V162 relay and depending on the model, applies a control voltage or voltage free signal. The control sequence is as follows:

1. A voltage deviation is detected starting the initial time delay.
2. The time delay expires & a tap change command is output.
3. The tap change contact closure will remain until the auxiliary contact on the OLTC opens for one (1) second minimum.
4. The interval time delay is initiated.
5. Sequence 2 to 4 will repeat at the rate determined by the Interval timer setting until the sensed voltage falls back to within pre-set bandwidth limits.

CONTROL OUTPUT CONTACTS

Tap raise command output: One N/O self reset
Tap lower command output: One N/O self reset
Undervoltage blocking output: One C/O self reset
Overvoltage alarm output: One C/O self reset
Tap changer fail alarm output: One C/O self reset
Power supply fail alarm: One N/O contact **

** Picked up when power applied & relay healthy.
10A 250V AC resistive contact rating.

OUTPUT CONTACTS (Idec RH PCB mounting type)

A common output relay for all phases is fitted with 2 changeover self reset contacts.

Maximum Contact Capacity (Amps)

Voltage	DC			AC		
	30	125	250	110	220	250
Resistive	10	2.4	1.2	10	7	6.6
Inductive L/R 7ms	7.5	1.8	0.9	7.5	5	4.4

Make & Carry for 200ms

30A at 250V DC resistive

Maximum Break Capacity

0.34A at 250V DC inductive (40ms)

AUXILIARY POWER SUPPLY

20-70V DC switchmode supply or
40-275V AC / 40-300V DC switchmode supply
Burden less than 10VA. If required the monitored voltage may also be used as the auxiliary supply.

Inputs:

A switchmode power supply is incorporated which provides a low burden to the auxiliary supply and operates over the range 40 to 265V AC & 40 to 300V DC. Peak input current is 3A at 40V DC & 1A at 40V AC.

Input Transients:

Withstands multiple high energy transients & ring waves in accordance with IEEE28 - ANSI C26.1 Cat. II, accordingly:

- 0.5uS 100KHz 6KV O/C, 500A S/C, 4J
- 1.2/50uS 6KV O/C
- 8/20uS 3KA S/C, 80J clamped at 1,000V

Mains conducted EMI within limits specified by AS 3548 Class B.

Isolation:

The inputs are isolated from the outputs in accordance with AS 3260 Class II Limited Current Circuitry, accordingly:

- Withstand voltage of 2.5Kv RMS 50Hz for one minute
- Creepage & clearance distance greater than 4mm
- Output leakage current less than 0.25A to earth

Power Supply Alarm Relay:

A normally closed contact rated at 10A 250V AC & isolated as per AS 3260 is energised when both the auxiliary supply & internal 24V DC rail is within acceptable limits. The *relay faulty* alarm output will be set if the incoming supply or switchmode circuit fails.

Output Protection:

Outputs will withstand continuous short circuit. Output regulators & switching control regulator are thermally protected.

INSULATION WITHSTAND

In accordance with IEC 255-5:
2KV RMS between input & frame, output & frame, & output & input. 1.2/50 5KV impulse between each terminal & earth, between circuits not normally connected together & between terminals of the same circuit.

NOISE IMMUNITY

Withstands the high frequency interference test detailed in IEC 255-22-1.

OPERATING TEMPERATURE RANGE

-5 to +55 degrees Celsius ambient operating temperature range.



Visit www.rmspl.com.au for the latest product information.

Due to RMS continuous product improvement policy this information is subject to change without notice. 2V162/Issue K/01/09/00/3/12

In QUAD Connection

THESE CONNECTIONS ARE ONLY REQUIRED IF THE RELAY IS SETUP TO ACCEPT A CONTROL SIGNAL FROM THE OLTC ACKNOWLEDGING THAT A TAP CHANGE IS IN PROGRESS.

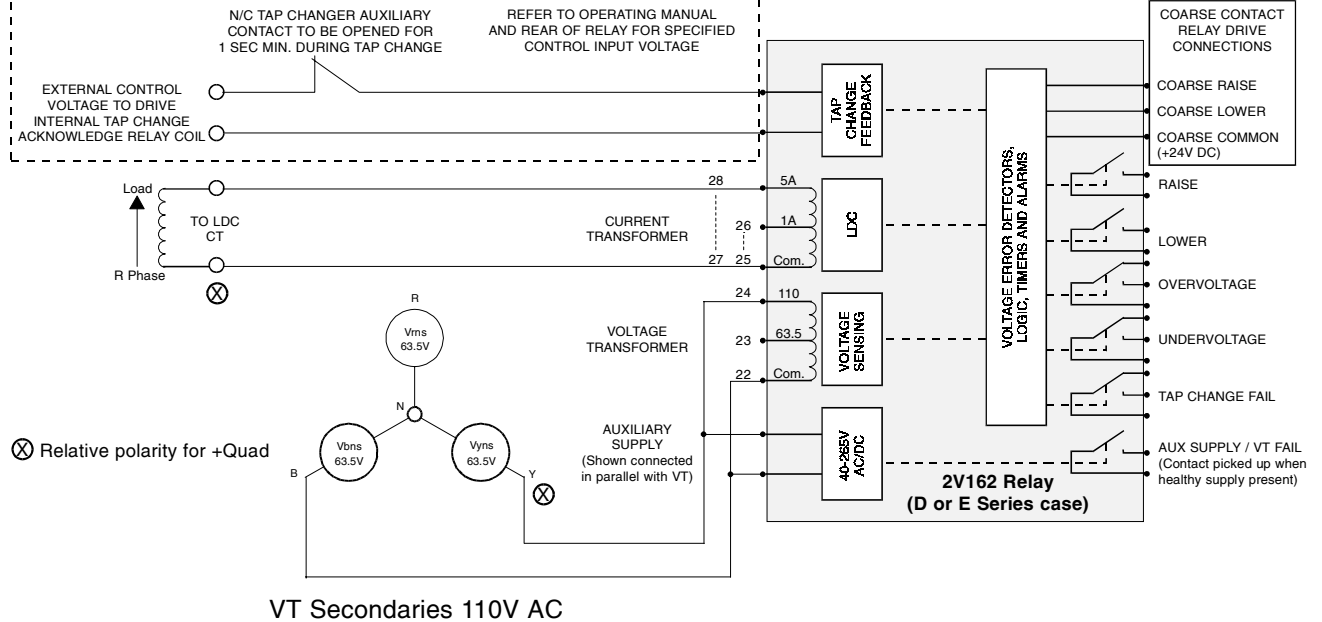

In PHASE Connection

THESE CONNECTIONS ARE ONLY REQUIRED IF THE RELAY IS SETUP TO ACCEPT A CONTROL SIGNAL FROM THE OLTC ACKNOWLEDGING THAT A TAP CHANGE IS IN PROGRESS.

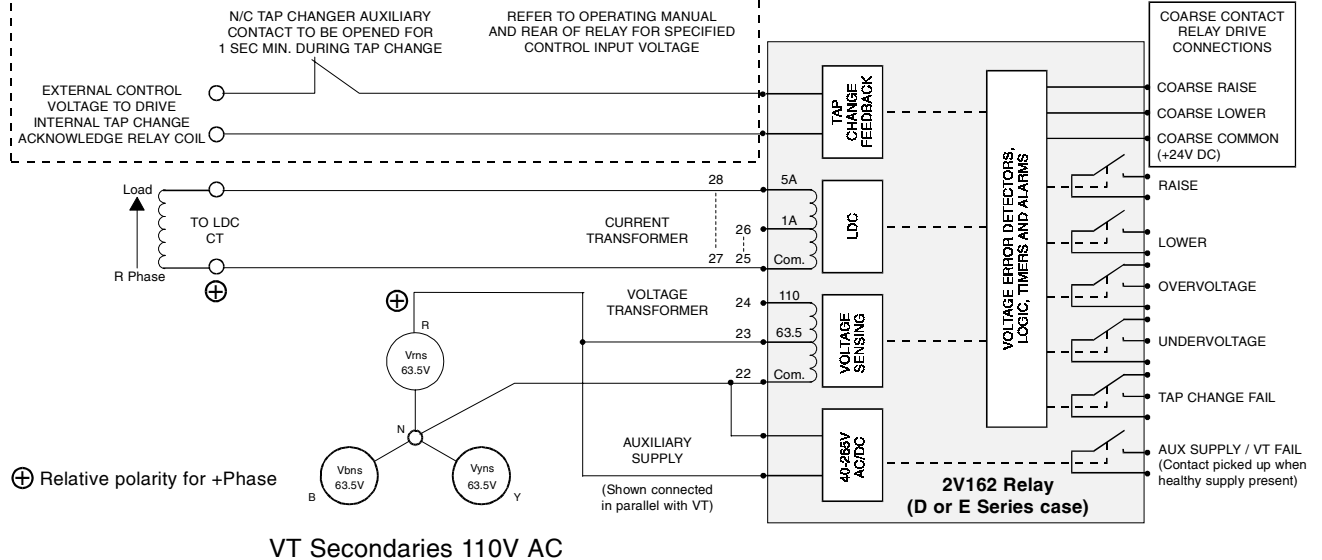

CONNECTION NOTES

The connection wiring shown is for relays mounted in D or E Series cases only and will vary slightly for other models. Refer to the specific operating manual for guidelines

All relay contacts are shown with a healthy supply applied, the 2V162 in a balanced condition, auxiliary supply connected in parallel with the sensed voltage and 5 Amp CT tap LDC input wired.



AS/NZS ISO9001-94
REGISTRATION
6869

Visit www.rmspl.com.au for the latest product information.

Due to RMS continuous product improvement policy this information is subject to change without notice. 2V162/Issue K/01/09/00/4/12

Rear Panel Terminals



2V162K4 Rear Panel Terminations.
D & E Series case

All terminal blocks are demountable except
for the LDC CT inputs.

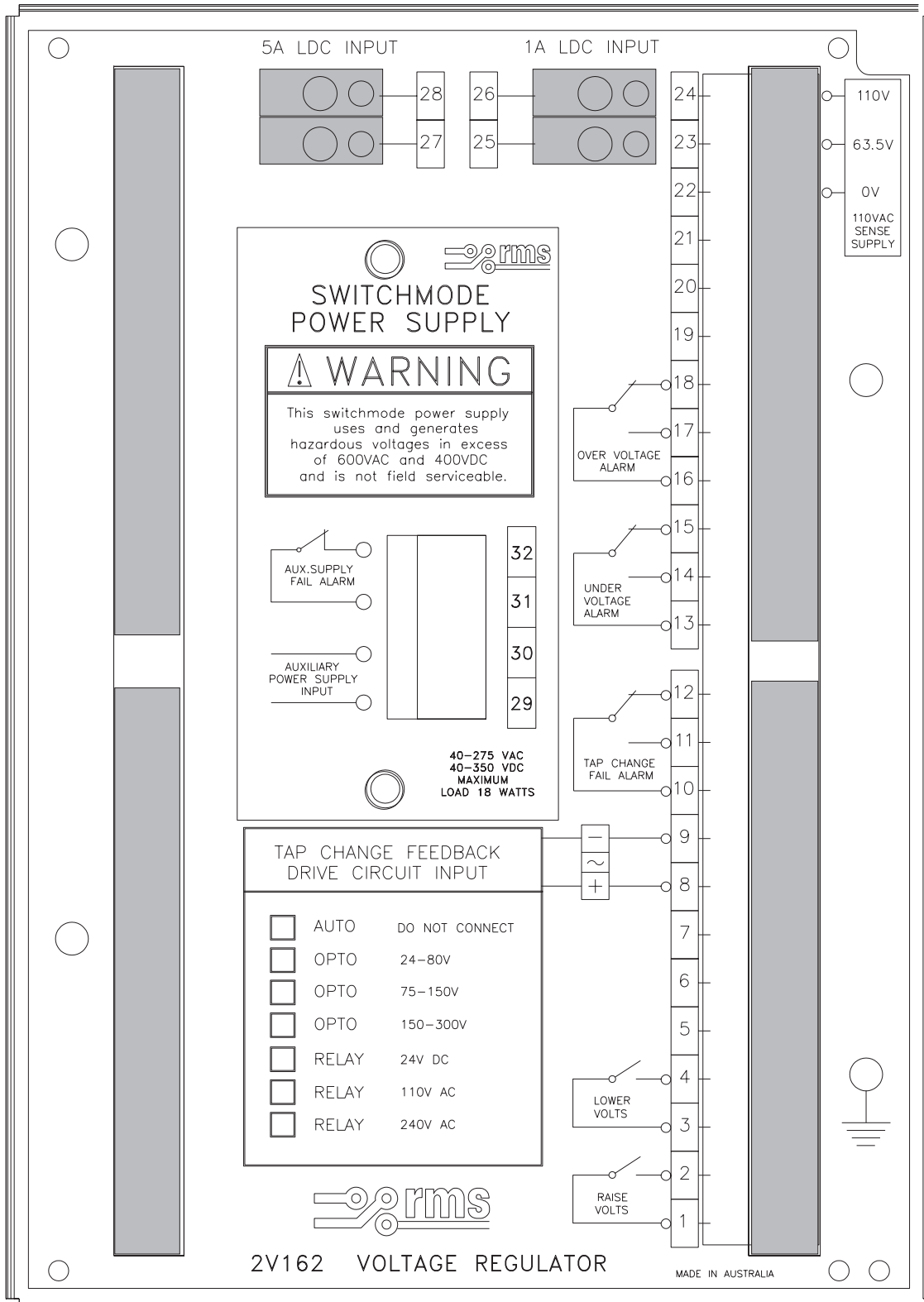

AS/NZS ISO9001-94
REGISTRATION
6869

Visit www.rmspl.com.au for the latest product information.

Due to RMS continuous product improvement policy this information is subject to change without notice. 2V162/Issue K/01/09/00/5/12

Enclosure Details



D Series flush, projection or semi-projection mount Case

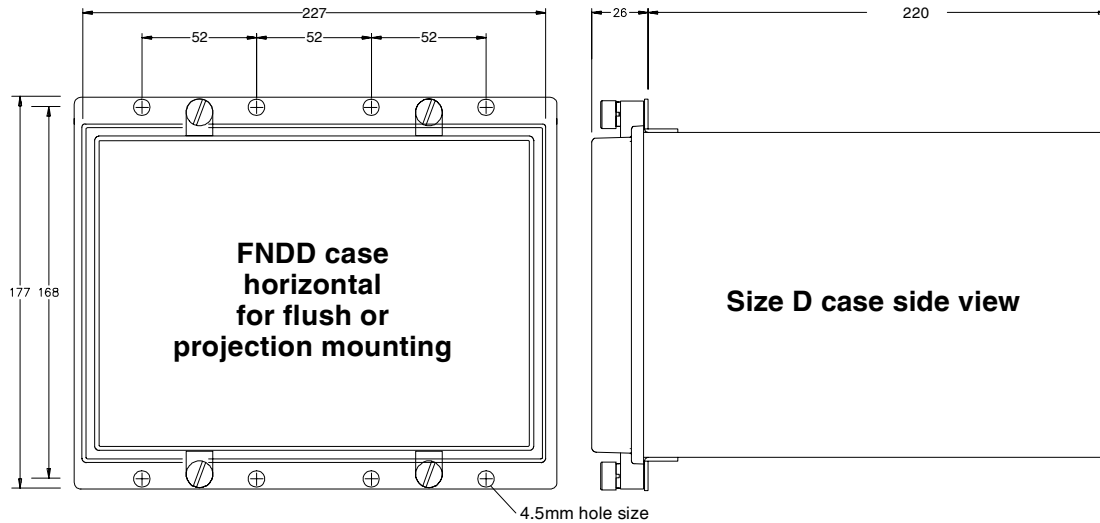

FNDD Flush Mount Case Panel Cut Out Details (Note that the relay may be specified for "VERTICAL" or "HORIZONTAL" mounting)

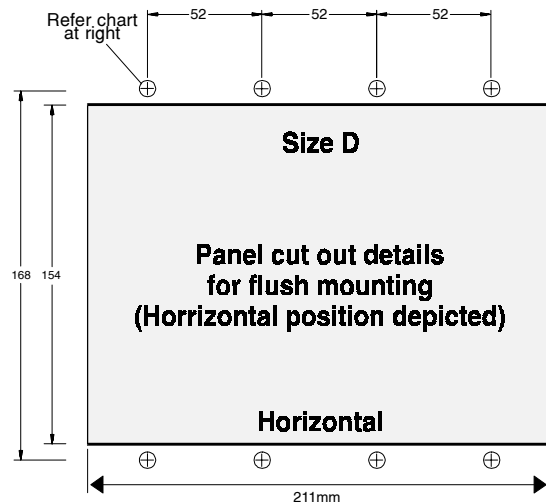

Panel Mounting Screws

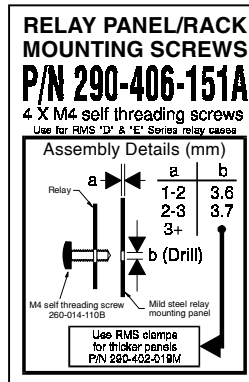

Size H, S & D cases may be flush mounted to mild steel panel up to 3mm thick using the M4 self threading screws provided with the case. Panel mounting is simplified due to the location of the fixing screws at the front face of the relay. The appropriate hole sizes for mounting are indicated at right.

For panels thicker than 3mm the optional panel mounting clamps should be specified.

Size 8 E Series case for 1/2 width 4U high 19 inch rack mounting

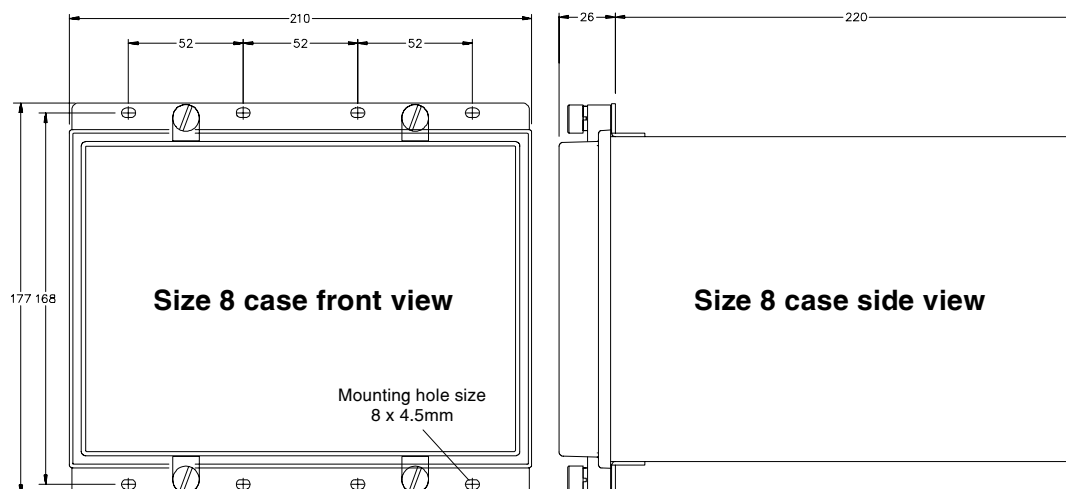

AS/NZS ISO9001-94
REGISTRATION
6869

Visit www.rmspl.com.au for the latest product information.

Due to RMS continuous product improvement policy this information is subject to change without notice. 2V162/Issue K/01/09/00/6/12

Mounting Adaptors

INTRODUCTION

AVE Relays of various types were deployed in large numbers before the advent of solid state electronic relays for the control of on load transformer tap changers. These relays are of an electromechanical design utilising a plunger suspended by leaf springs within a voltage sensing solenoid. Movement of this plunger in response to system line voltage variations causes the output of *RAISE* & *LOWER* commands to the on load tap changer.

Early models used electromechanical disc timers which were often later replaced in the field with more reliable solid state time delay elements as used in the *AVE5* model. Line drop compensation, if required, was provided by an external control unit.

AVE Relays are now reaching the end of their service life & have been outdated by the improved features & performance of modern solid state equipment.

The following data describes the adaptor kits & services available from RMS to mount & wire the 2V162K4 Voltage Regulator Relay for the effective replacement of AVE models located in existing installations.

Page 11 of this publication provides a specification pro-forma which may be completed & submitted to RMS for evaluation & quotation purposes.

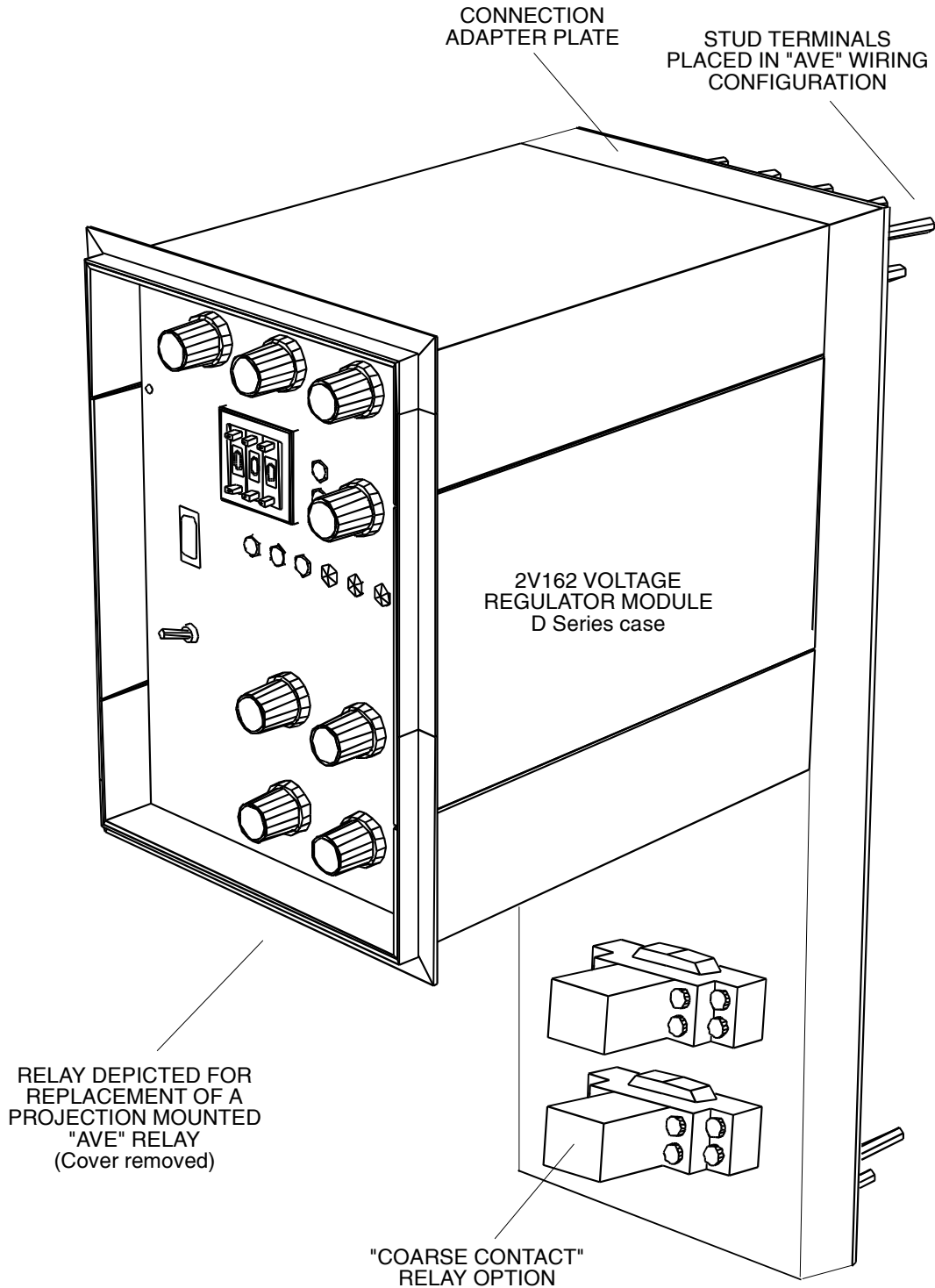

AS/NZS ISO9001-94
REGISTRATION
6869

Visit www.rmspl.com.au for the latest product information.

Due to RMS continuous product improvement policy this information is subject to change without notice. 2V162/Issue K/01/09/00/7/12

AVE Adaptor Selection



DESIGN CONSIDERATIONS

There are three primary issues to be considered when determining the system needs for replacement of an AVE type relay in an existing installation:

- Mounting
- Wiring
- Functional considerations

RMS is able to supply AVE replacement kits to suit a wide range of applications. The components & services required are supplied as follows:

1. The new solid state voltage regulator relay
2. Adaptor kit to match the existing installation
3. Wiring loom to interface the new VRR

Items 1 & 2 are standard products which may be specified from the selection chart opposite. Modifications to suit special field requirements may be quoted & undertaken by RMS upon request.

Item 3 is heavily dependent on the original control system design & any customer requirements to upgrade the system by incorporating new features available in the 2V162K4 such as LDC, overvoltage alarms, tap change acknowledge configuration, output contacts etc. This item is therefore quoted based on the information provided by the customer on page 11. Cost for the wiring loom is based on the number of wires required & the quantity ordered for manufacture.

The following sections may be used to assist in the specification of the components required to adapt the RMS 2V162K4 Voltage Regulator Relay to a specific field application.

PROJECTION MOUNT KIT

To replace a particular AVE relay type an adaptor plate must be fitted to the rear of the 2V162K4 Voltage Regulator Relay. This adaptor plate incorporates a wiring loom attached to stud terminals arranged to match the positions of the existing AVE Relay. The other end of the wiring loom is terminated with Phoenix connector blocks designed to plug into the 2V162K4.

Holes in the adaptor plate are positioned to facilitate projection mounting of the 2V162K4 using the existing holes in the panel. Cover panels are supplied to provide finger protection for all electrical terminations.

FLUSH MOUNTING KIT

For relay panels where the AVE Relay is flush mounted an additional adaptor plate is required. A special flush mount panel is attached to the 2V162K4 relay using clamps provided & then fitted through the existing panel cut out. A locating flange at the base of the flush mount panel holds the relay assembly in place while the top of the plate is screwed into position.

SYSTEM OPERATION

The standard 2V162K4 Voltage Regulating Relay provides numerous features for the control of on load tap changers. Some of these features may not be required to emulate the old electromechanical relay being replaced but may be desirable for incorporation into the OLTC control system.

Numerous options therefore exist for the customer to specify the wiring from the 2V162K4 output terminals to the AVE configured stud terminals on the adaptor plate.

Details of the functional configuration of the relay may be specified on page 11 & submitted to RMS for evaluation & quotation.

COARSE CONTACTS ADAPTER

The AVE4 & AVE5 relays were sometimes specified with an option called *COARSE CONTACTS*. These contacts were in addition to the fine raise & lower contacts & would only be picked up when large system voltage errors were detected.

If either the coarse raise or coarse lower contact was picked up then an instantaneous output was signalled by closing a N/O relay contact. This contact was wired to a separate external timing circuit which would initiate a very fast raise or lower command to the tap changer when the COARSE error was exceeded.

To avoid having to redesign the wiring circuits in existing systems where coarse contacts are used an additional coarse contacts adaptor kit may be fitted to the 2V162 relay (D or E Series case).

This kit comprises two additional output relays which attach to the connection adaptor plate & interface between the 2V162K4 & the stud terminals via a separate wiring loom.

The coarse contacts may be specified to operate for a fixed setting of 2.8 times the fine bandwidth setting on the front panel of the 2V162. ie. if the error detector bandwidth is set to 1% the coarse contacts will pick up if the voltage error exceeds + or - 2.8%. This may be factory calibrated to a specific multiplier if required.

Alternatively the coarse contacts voltage setting may be specified as an adjustable control as described on page 9.

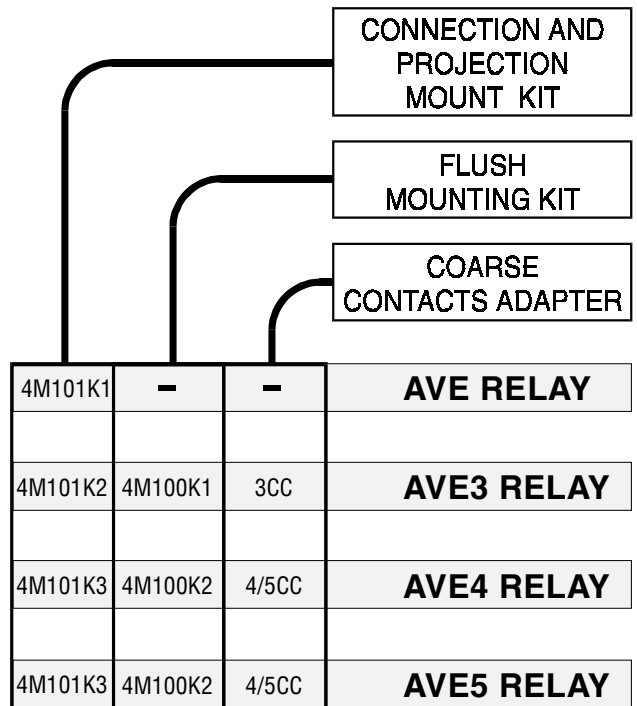

Visit www.rmspl.com.au for the latest product information.

Due to RMS continuous product improvement policy this information is subject to change without notice. 2V162/Issue K/01/09/00/8/12

Adjustable Coarse Contacts

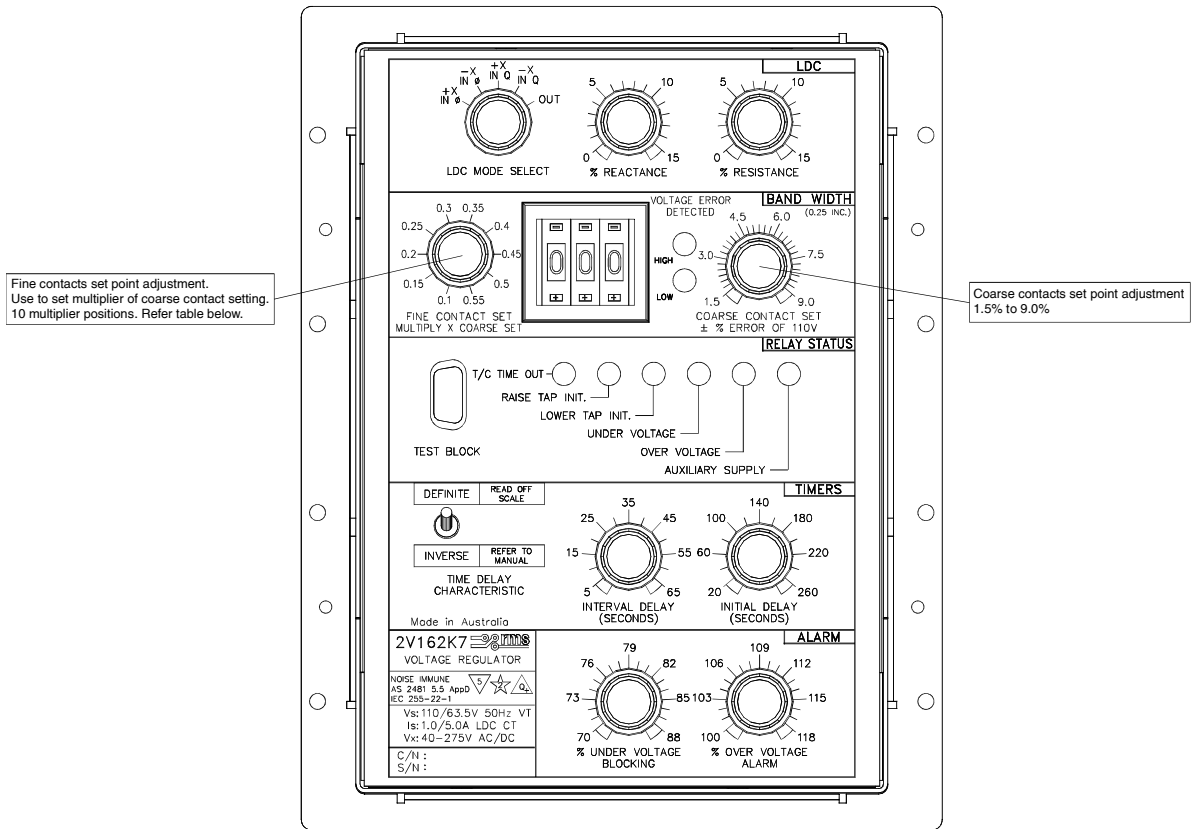

Coarse Setting	Multiplier setting for 2V162 FINE CONTACTS									
	0.1	0.15	0.2	0.25	0.3	0.35	0.4	0.45	0.5	0.55
1.50%	0.15%	0.23%	0.30%	0.38%	0.45%	0.53%	0.60%	0.68%	0.75%	0.83%
1.75%	0.18%	0.26%	0.35%	0.44%	0.53%	0.61%	0.70%	0.79%	0.88%	0.96%
2.00%	0.20%	0.30%	0.40%	0.50%	0.60%	0.70%	0.80%	0.90%	1.00%	1.10%
2.25%	0.23%	0.34%	0.45%	0.56%	0.68%	0.79%	0.90%	1.01%	1.13%	1.24%
2.50%	0.25%	0.38%	0.50%	0.63%	0.75%	0.88%	1.00%	1.13%	1.25%	1.38%
2.75%	0.28%	0.41%	0.55%	0.69%	0.83%	0.96%	1.10%	1.24%	1.38%	1.51%
3.00%	0.30%	0.45%	0.60%	0.75%	0.90%	1.05%	1.20%	1.35%	1.50%	1.65%
3.25%	0.33%	0.49%	0.65%	0.81%	0.98%	1.14%	1.30%	1.46%	1.63%	1.79%
3.50%	0.35%	0.53%	0.70%	0.88%	1.05%	1.23%	1.40%	1.58%	1.75%	1.93%
3.75%	0.38%	0.56%	0.75%	0.94%	1.13%	1.31%	1.50%	1.69%	1.88%	2.06%
4.00%	0.40%	0.60%	0.80%	1.00%	1.20%	1.40%	1.60%	1.80%	2.00%	2.20%
4.25%	0.43%	0.64%	0.85%	1.06%	1.28%	1.49%	1.70%	1.91%	2.13%	2.34%
4.50%	0.45%	0.68%	0.90%	1.13%	1.35%	1.58%	1.80%	2.03%	2.25%	2.48%
4.75%	0.48%	0.71%	0.95%	1.19%	1.43%	1.66%	1.90%	2.14%	2.38%	2.61%
5.00%	0.50%	0.75%	1.00%	1.25%	1.50%	1.75%	2.00%	2.25%	2.50%	2.75%
5.25%	0.53%	0.79%	1.05%	1.31%	1.58%	1.84%	2.10%	2.36%	2.63%	2.89%
5.50%	0.55%	0.83%	1.10%	1.38%	1.65%	1.93%	2.20%	2.48%	2.75%	3.03%
5.75%	0.58%	0.86%	1.15%	1.44%	1.73%	2.01%	2.30%	2.59%	2.88%	3.16%
6.00%	0.60%	0.90%	1.20%	1.50%	1.80%	2.10%	2.40%	2.70%	3.00%	3.30%
6.25%	0.63%	0.94%	1.25%	1.56%	1.88%	2.19%	2.50%	2.81%	3.13%	3.44%
6.50%	0.65%	0.98%	1.30%	1.63%	1.95%	2.28%	2.60%	2.93%	3.25%	3.58%
6.75%	0.68%	1.01%	1.35%	1.69%	2.03%	2.36%	2.70%	3.04%	3.38%	3.71%
7.00%	0.70%	1.05%	1.40%	1.75%	2.10%	2.45%	2.80%	3.15%	3.50%	3.85%
7.25%	0.73%	1.09%	1.45%	1.81%	2.18%	2.54%	2.90%	3.26%	3.63%	3.99%
7.50%	0.75%	1.13%	1.50%	1.88%	2.25%	2.63%	3.00%	3.38%	3.75%	4.13%
7.75%	0.78%	1.16%	1.55%	1.94%	2.33%	2.71%	3.10%	3.49%	3.88%	4.26%
8.00%	0.80%	1.20%	1.60%	2.00%	2.40%	2.80%	3.20%	3.60%	4.00%	4.40%
8.25%	0.83%	1.24%	1.65%	2.06%	2.48%	2.89%	3.30%	3.71%	4.13%	4.54%
8.50%	0.85%	1.28%	1.70%	2.13%	2.55%	2.98%	3.40%	3.83%	4.25%	4.68%
8.75%	0.88%	1.31%	1.75%	2.19%	2.63%	3.06%	3.50%	3.94%	4.38%	4.81%
9.00%	0.90%	1.35%	1.80%	2.25%	2.70%	3.15%	3.60%	4.05%	4.50%	4.95%



AS/NZS ISO9001-94
REGISTRATION
6869

Visit www.rmspl.com.au for the latest product information.

Due to RMS continuous product improvement policy this information is subject to change without notice. 2V162/Issue K/01/09/00/9/12

Adaptor Kit Dimensions



4M101K1 Adapter (Adapter for "AVE" model)

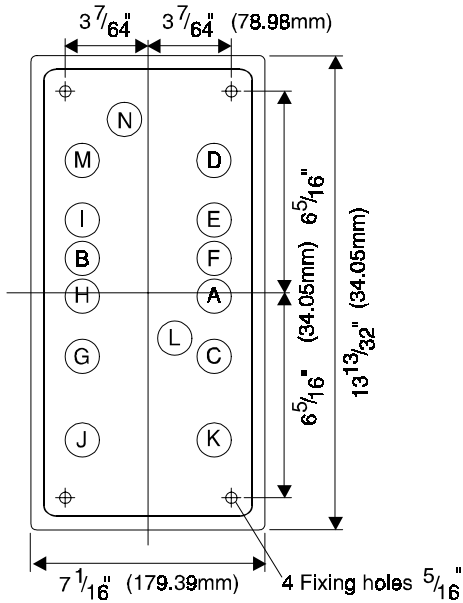

4M101K2 Adapter (Adapter for "AVE3" model)

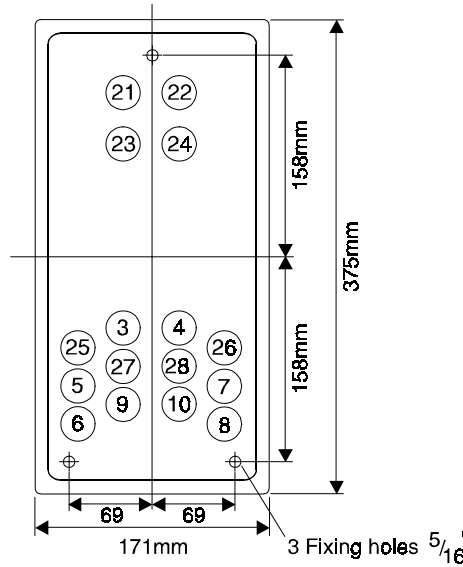

4M101K3 Adapter (Adapter for "AVE4/5" models)

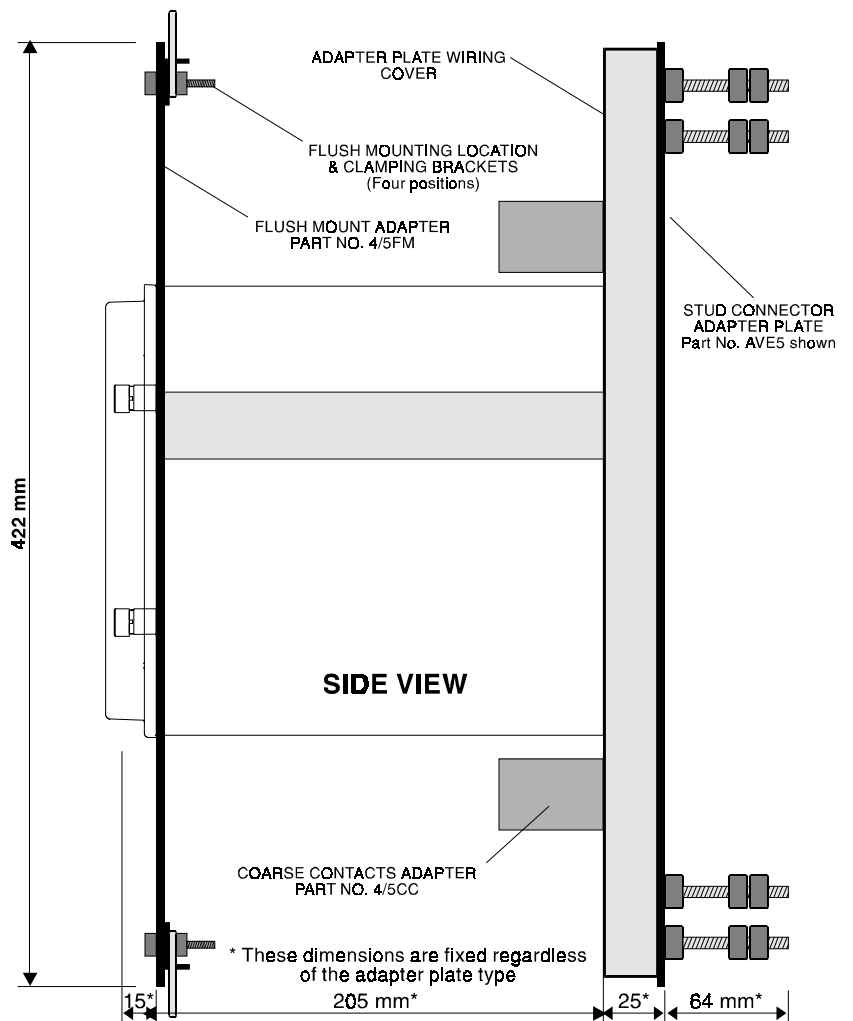
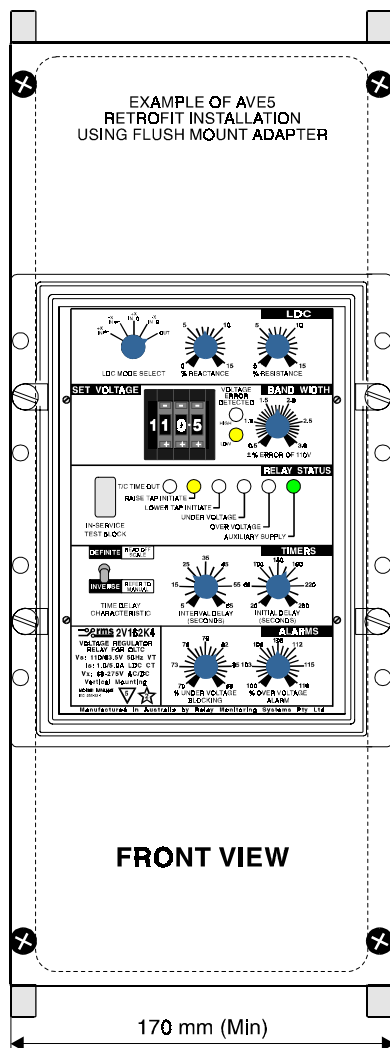
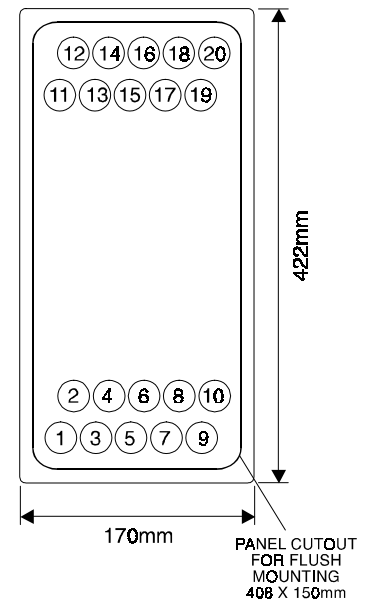

Visit www.rmspl.com.au for the latest product information.

Due to RMS continuous product improvement policy this information is subject to change without notice. 2V162/Issue K/01/09/00/10/12

AVR Upgrade Specification



Complete both sides of this page, detach & return to RMS for technical evaluation & quotation.

Existing VRR type: _____

Quantity required for quotation: _____

Approximate date required: _____

Check required items & record existing terminal numbers from layout option. 8

Mounting

- Flush
- Projection
- Other - specify: _____

2V162K4 Terminals Existing Terminals

Voltage Sensing Input

- 63.5V AC 23 22
- 110V AC 24 22
- Other - Specify: _____

Auxiliary Supply Input

- Power from VT 29 30
 - Specify Aux: _____
- Aux. range: 40-275V AC
40-300V DC
- + -

Tap Change Feedback

- Normally closed external contact which opens for duration of T/C. 29 9
- 8 — 30

2V162 wired such that the feedback circuit derives power from the auxiliary supply input.

- Automatic - Feedback circuit not available

Termination Style

- Stud - Size: _____
- Terminal layout (Select from A to D):

Terminal Layout Options (Viewed from FRONT)

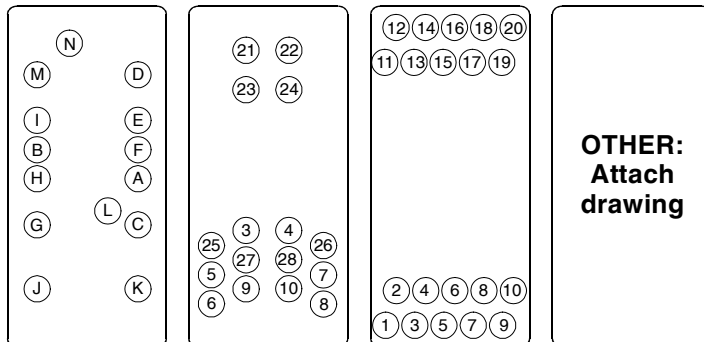

- Other - specify: _____

Name: _____

Position: _____

Company: _____

Address: _____

Phone: _____ Fax: _____

LDC Current Sensing Input

- 1A AC 25 26
- 5A AC 27 28
- Other - Specify: _____

Alarm Output Wiring

- Undervoltage alarm 13 14 15
- Overvoltage alarm 16 17 18
- Tap change fail 10 11 12
- Aux supply fail (Normally open for healthy supply) 31 32

Control Output Wiring

- N/O Tap raise 1 2
- N/O Tap lower 3 4
- N/O Coarse raise 7 COIL 5
- N/O Coarse lower 7 COIL 6

For evaluation & quotation return to:

Relay Monitoring Systems Pty Ltd

Head Office
456 Haughton Road
Clayton, VIC 3168
P.O. Box 166
Huntingdale, VIC 3166
Tel: (03) 9562 8369
Fax: (03) 9562 8367

N.S.W. Sales Support
P.O. Box 20
Fairfield, NSW 2165
Tel: (02) 757 2678
Fax: (02) 725 5363

Australian Designed & Manufactured Protective Relays



Visit www.rmspl.com.au for the latest product information.

Due to RMS continuous product improvement policy this information is subject to change without notice. 2V162/Issue K/01/09/00/11/12

Ordering Information

Generate the required ordering code as follows:
e.g. 2V162 BAAAAB + AUTOMATIC

	1	2	3	4	5	6	+	T/C P/N
2V162								

1 AUXILIARY SUPPLY RANGE

- A 20-70V DC
- B 40-300V DC / 40-275V AC

2 VOLTAGE SENSING FREQUENCY

- A 50Hz (+/- 2Hz)
- B 60Hz (+/- 2Hz)

3 OVERVOLTAGE ALARM

- A Standard
- B Fast tap down designation on front panel & 500ms delay on output contact pick up.

4 REMOTE VOLTAGE SETTING

- A Not required (Standard)
- B Required (1.0V setting resolution) Vertical case format only

5 ADJUSTABLE COARSE CONTACTS

- A Not required
- B Required

6 CASE

- A Size 8E Case for rack mounting (4u high, 1/2 width)
- B D size Case for flush mounting in vertical format
- C D size case for flush mounting in horizontal format
- D Semi projection mount in vertical format (Specify)
- E Semi projection mount in horizontal format (Specify)

TAP CHANGE (T/C) FEEDBACK MECHANISM

Specify & order as a separate item:

Automatic mode

P/N AUTOMATIC (No feedback connection required)

Opto-isolated input

P/N 660-295-404	24-80V AC/DC
P/N 660-295-405	75-150V AC/DC
P/N 660-295-406	150-300V AC/DC

Relay coil input

P/N 0041-125 B	12V DC
P/N 0041-127 B	24V DC
P/N 0041-129 B	48V DC
P/N 0041-120 B	110V DC
P/N 0041-133 B	240V AC

Australian Content

Unless otherwise stated the product(s) quoted are manufactured by RMS at our production facility in Melbourne Australia. Approximately 90% of our sales volume is derived from equipment manufactured in house with a local content close to 90%. Imported components such as semi-conductors are sourced from local suppliers & preference is given for reasonable stock holding to support our build requirements.

Quality Assurance

RMS holds NCSI (NATA Certification Services International), registration number 6869 for the certification of a quality assurance system to AS/NZS ISO9001-1994. Quality plans for all products involve 100% inspection and testing carried out before despatch. Further details on specific test plans, quality policy & procedures may be found in section A4 of the RMS product catalogue.

Product Packaging

Protection relays are supplied in secure individual packing cardboard boxes with moulded styrene inserts suitable for recycling. Each product & packing box is labeled with the product part number, customer name & order details.

Design References

The products & components produced by RMS are based on many years of field experience since Relays Pty Ltd was formed in 1955. A large population of equipment is in service throughout Australia, New Zealand, South Africa & South East Asia attesting to this fact. Specific product & customer reference sites may be provided on application.

Product Warranty

All utility grade protection & auxiliary relay products, unless otherwise stated, are warranted for a period of 24 months from shipment for materials & labour on a return to factory basis. Repair of products damaged through poor application or circumstances outside the product ratings will be carried out at the customers expense.

Standard Conditions of Sale

Unless otherwise agreed RMS Standard Terms & Conditions (QF 907) shall apply to all sales. These are available on request or from our web site.



Relay Monitoring Systems Pty Ltd

6 Anzed Court, Mulgrave, Victoria 3170, AUSTRALIA

Tel: 61 3 9561 0266 Fax: 61 3 9561 0277 Email: rms@rmspl.com.au Web: www.rmspl.com.au