

## Features

### SYSTEM FEATURES

- Large back lit display panel
- System status LED indicators
- Simple menu setting procedure
- Wide auxiliary supply range with fail alarm contact
- Self diagnosis & fail alarm
- Size 4M case
- Made in Australia

### VOLTAGE CONTROL

- Line drop compensation with 1A & 5A CT inputs
- Z Compensation
- 63.5 & 110V AC VT inputs
- Definite time & inverse time delays
- Independent fine & coarse voltage bandwidth windows
- Over & under voltage alarms
- Under voltage blocking function
- Tap change fail alarm
- Two digital input load step stages
- Overcurrent blocking

### METERING & EVENT RECORDING

- Line voltage display
- Line current display
- Tap position indicator
- Tap rate of change alarm
- Tap change event counter
- Tap position mA output
- Line voltage mA output

### COMMUNICATION

- Non platform specific PC programming software:  $\mu$ MATRIXwin
- Optically isolated communication ports
- MODBUS RTU compatible network protocol

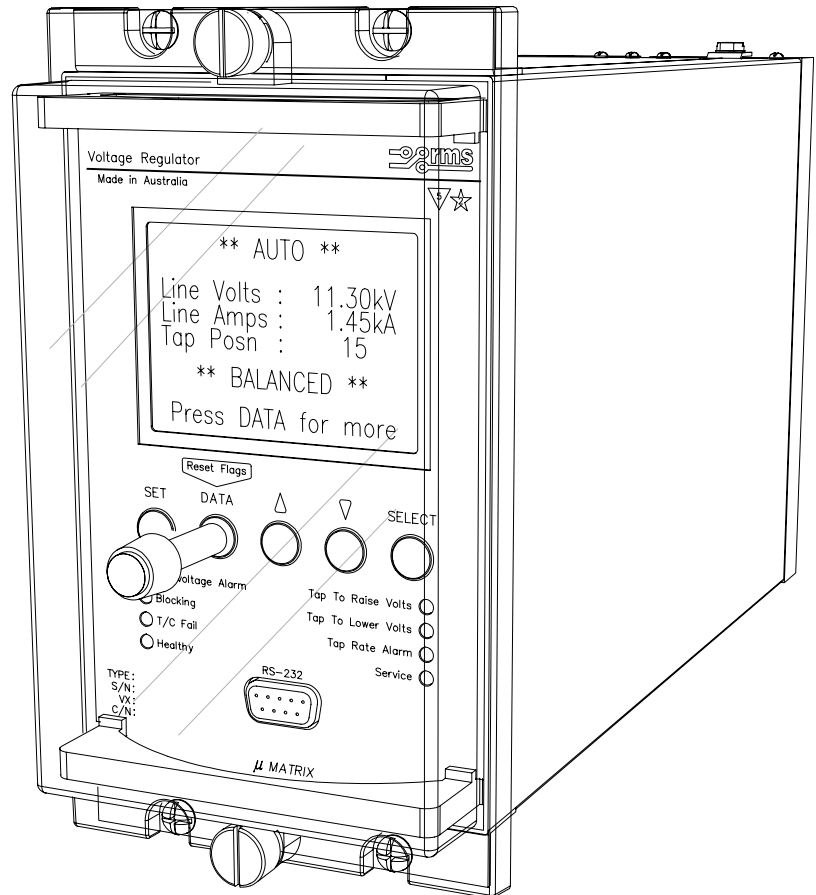

2V164 depicted in a 4M56 case

## Application

Made in Australia

The 2V164 Series relays are designed for the control of motor driven on-load power transformer tap changers.

The 2V164 Voltage Regulator Relay continuously monitors the transformer output voltage & current & provides "RAISE" & "LOWER" control commands to the on-load tap changer such that the load centre is automatically maintained within acceptable limits. Small variations in supply frequency will not affect the system performance.

When designing the 2V164, considerable emphasis was placed on producing a relay, which would be very simple to install, set up & operate in the field. The result is a simple yet effective & very dependable voltage regulator relay available at a competitive price. The standard Micro MATRIX human machine interface (HMI) is combined with fully solid state voltage sensing & measuring circuitry to provide high accuracy, simple set up & flexible operation.

### PARALLEL CONTROL SCHEMES

Parallel control schemes are available to meet a range of transformer control configurations based on the master / follower principal. These systems are supplied fully wired in 19" sub rack frames ready for integration into customer panels. Up to 4 transformers operating in parallel on one or two groups are possible.

For further details refer to the RMS 1M122A, 1M122D & 2V165 technical bulletins which provide details on our range of transformer parallel control systems.

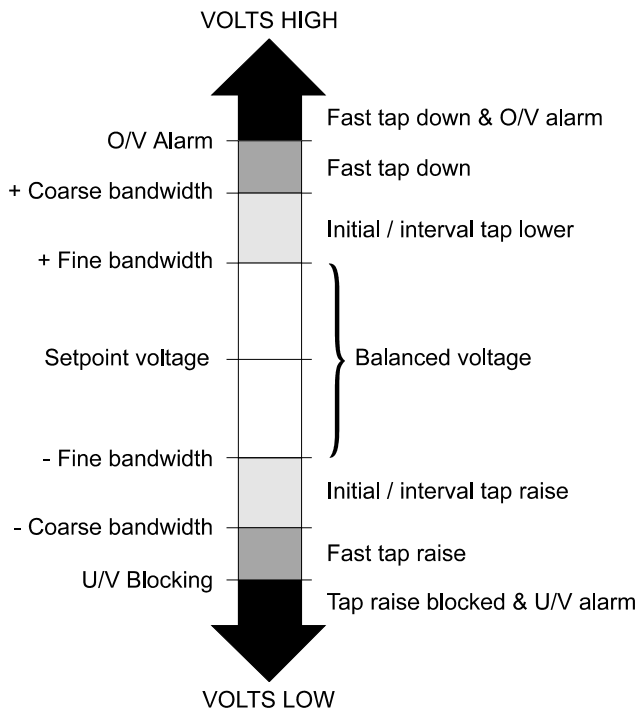

Figure 1: User defined voltage set points

#### SETPOINT VOLTAGE RANGE

90V to 130V in 0.1V steps.  
110V & 63.5V nominal inputs.

#### “FINE” VOLTAGE BANDWIDTH SETTING (SENSITIVITY)

0.3 V to 5.0V in 0.1V steps.

The bandwidth setting should be made in accordance with the relative step voltage of the tap changer. A narrow bandwidth may result in the tap changer *hunting* between adjacent taps.

#### INITIAL RAISE / LOWER TIMER

10s to 300s in 10s steps.

The initial time delay between the detection of an error in the monitored voltage & the resultant tap change output, is switch selectable as either a definite time or true inverse time response.

The initial time delay starts when the voltage deviation exceeds the upper or lower limit. The respective instantaneous HIGH / LOWER LED illuminates.

If the deviation falls back to within bandwidth limits before the pre set time delay is completed, the timer is reset.

At the completion of the pre set time delay the respective RAISE / LOWER tap output contact will close.

#### INTERVAL TIME DELAY

1s to 100s in 1s steps.

The interval time delay only becomes active when the initial delay has caused a tap change but without affecting a balanced condition, ie. if more than one tap change operation is necessary to bring the voltage within set limits.

#### INVERSE TIME DELAY CHARACTERISTIC

In the inverse time mode, the initial time delay is inversely proportional to the ratio of deviation to bandwidth down to a minimum of a one-second delay. For example:

- ◆ When the detected error is equal to the selected bandwidth the time delay is equal to the delay setting.
- ◆ For a detected error of N times the selected bandwidth, the time delay is 1/N times the delay setting.

#### ACCURACY OF TIMERS

All timers +/-0.1s

## Voltage Control Functions

#### “COARSE” VOLTAGE BANDWIDTH SETTING

1V to 20V in 1V steps.

1s to 60s in 1s steps.

A second independent voltage control window can be set with a definite time delay. This can be used for a fast tap change function for large voltage deviations, which are outside the fine bandwidth window.

#### UNDER VOLTAGE BLOCKING FUNCTION

60V to 90V in 1V steps.

0s to 60s in 1s steps.

An undervoltage blocking function is combined with a definite time delay output.

Undervoltage blocking suppresses tap change operations during a system breakdown to avoid the tap changer mechanism from being driven to the top tap. The self reset Blocking alarm relay is activated when this element has timed out & a message reported on the HMI.

#### OVER VOLTAGE ALARM

110V to 140V in 1V steps.

0s to 60s in 1s steps.

An overvoltage alarm is combined with a definite time delay output. The self reset overvoltage alarm relay contact is activated when this element has timed out & a message reported on the HMI.

#### OVER CURRENT BLOCKING

50 to 150% in 5% steps – Can also be set to OFF

0s to 60s in 1s steps

Reset: >0.97Iset

When timed out all tap commands are inhibited / cancelled.

The self reset Blocking alarm relay is activated when this element has timed out & a message reported on the HMI.

#### SET POINT HYSTERESIS

All voltage set points have a hysteresis equal to 50% of the bandwidth voltage setting. Other values available on application.

#### LINE DROP COMPENSATION

Resistance & reactance compensation: 0V to 20V in 0.1V steps  
Settings are provided to cater for *in phase* & *in quad* connections, with either positive or negative reactance compensation.

Correct setting of the LDC requires the calculation of the resistive & reactive line-drops as a voltage with reference to the secondary side of the VT & the setting of the instrument transformer for IN PHASE or IN QUAD connection.

Z compensation is also available: 0 to +15% setting range.

#### VOLTAGE LOAD STEP INPUTS

-10% to +10% of the set point voltage in 0.5% steps

Two independent load step stages are provided. The voltage reduction or boost level for each stage can be independently set while a separate digital input is provided to initiate each stage. If both stages are initiated then the stage 2 level is operative.

#### OPERATIONAL INDICATORS

Red LED's on the front panel indicate the following conditions:

- Over voltage      Bus voltage above alarm setting
- Blocking          BUS voltage / current outside block settings
- Tap change fail    Tap change time out alarm
- Raise volts        Flash when timing / On for Raise tap initiate
- Lower volts        Flash when timing / On for Lower tap initiate
- Tap rate            Tap rate alarm level exceeded

#### TAP CHANGE FAIL ALARM

10s to 300s in 10s steps.

The tap change fail alarm timer is initiated when an out of bandwidth voltage error is detected. Time out will result in the alarm contact closing. The alarm timer & contact is reset when the sensed voltage has moved back to a balanced condition.

#### AUTO / MANUAL MODE CONTROL INPUT

A digital input is provided to change the relay from AUTO to MANUAL mode.

In AUTO mode the 2V164 will monitor the voltage & current inputs & output tap raise / lower commands to maintain the load center in accordance with the relay settings.

In MANUAL mode tap raise & lower commands are inhibited.

The Blocking & Overvoltage alarm outputs remain active.

The relay fail alarm remains active.

# Metering & Event Logging

### TAP POSITION INDICATOR

A tap position indicator input is provided to enable the transformer tap to be displayed on the HMI. The output from the RMS type 2V200 Tap Position Transducer is required for this function to operate. Refer to the 2V200 Technical Bulletin for details.

### TAP POSITION INDICATOR INPUT

For this function to operate an RMS type 2V200 transducer / sender unit is required at the tap changer. Refer to the 2V200 Technical Bulletin for application details.

The 2V200 is designed to interface to tap changes & convert one of the following parameters:

- an analogue voltage signal proportional to the tap position
- a binary coded decimal signal
- a BCD signal

The 2V200 converts any of these inputs to a frequency signal proportional to the tap position.

The 2V164 VRR is then simply programmed with the number of tap positions within the range 10 to 30. Scaling is carried out automatically so that the correct tap position is indicated on the 2V164 display.

A 4-20mA analogue output proportional to tap position is also provided by the 2V164 for local panel indication or interface to SCADA.

### VOLTAGE DISPLAY

The HMI displays the line voltage. The VT ratio may be entered so that the HMI display reads in primary voltage. A 4-20mA analogue output is also provided.

Display range (Secondary): 10-145V  
VT setting range: 0.11KV to 132.00KV

### CURRENT DISPLAY

The HMI displays the line current from the LDC input. The CT ratio may be entered so that the HMI display reads in primary current.

Display range (Secondary): 0.1-1.35Is  
CT setting range: 1A to 6.00KA

### TAP CHANGE EVENT COUNTER

A record is maintained & displayed of the number of tap operations since this function was last reset. The tap rate indicator takes account of all tap changes initiated by the 2V164 tap raise / lower contacts. Manual taps initiated by external control contacts are not included.

### RANGE OF TAP OPERATION

A record is maintained & displayed of the minimum & maximum tap position reached since this function was last reset.

### TIME ELAPSED SINCE TAP COUNT RESET

A record is maintained & displayed of the time in hours since the tap count was last reset.

### TAP RATE ALARM

The 2V164 records & displays the rate at which tap raise/lower commands have been output over the preceding 15-minute period. If the set point rate is exceeded (taps per hour), an alarm contact is picked up. This alarm contact is automatically reset when a tap rate lower than the alarm set point is updated to the display or when the tap count is manually reset. The tap rate indicator takes account of all tap changes initiated by the 2V164 tap raise / lower contacts. Manual taps initiated by external control contacts are not included.

### TAP POSITION INDICATOR ANALOGUE OUTPUT

A single tap position indicator analogue output signal is provided for interface to an RTU. The analogue output is linked to the tap position as follows:

- Output: 4 to 20mA  
Compliance voltage: 5V  
Maximum burden: 250 Ohms  
Accuracy: +/-3%  
Analogue output:
- Tap 1 4mA
  - Tap N 20mA
- Where N = maximum selected tap setting

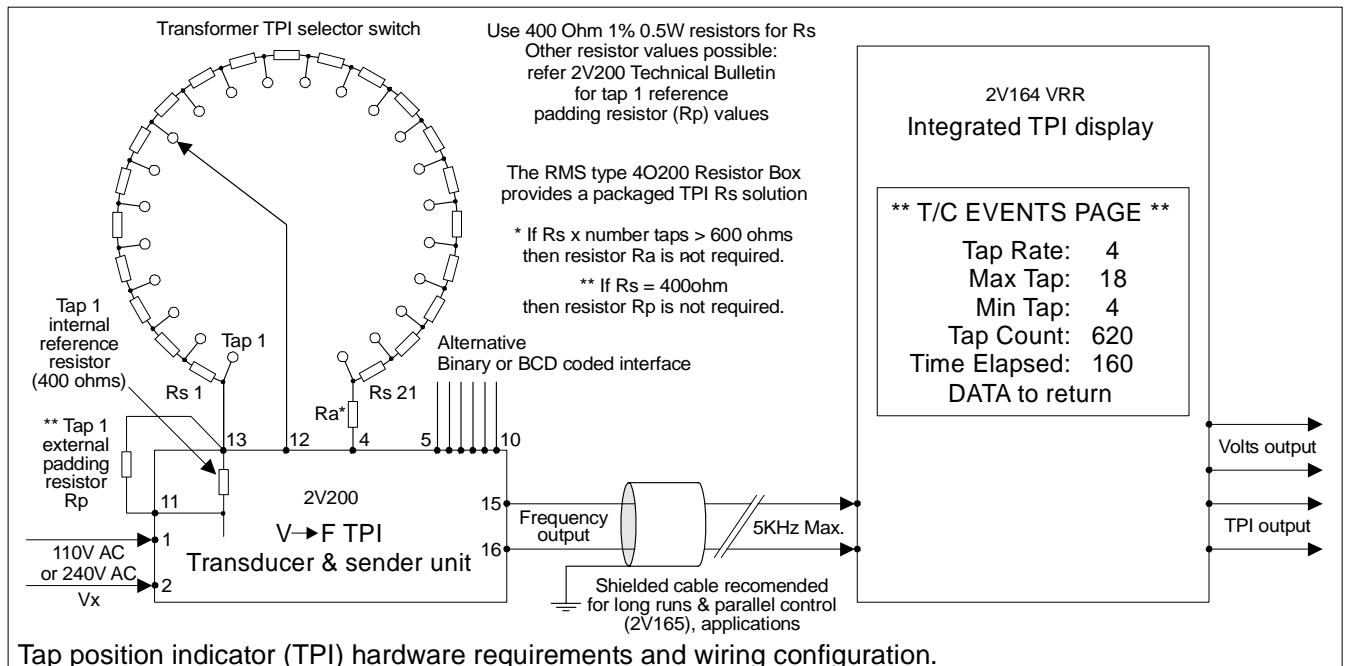

Figure 2

## RELAY CONFIGURATION USING $\mu$ MATRIXwin

The purpose of the  $\mu$ MATRIXwin application is to provide display, configuration and diagnostic facilities required to support the entire family of  $\mu$ MATRIX digital relays. The prime functions of the application are:

### Create a setting file off line

To create & view relay setting files at your PC without the need for a relay;

### Relay setting

To download a setting file (UMP) into a relay connected to a PC;

To display & change settings in a connected relay;

### Relay status

To display the Status of nominated inputs and outputs of a connected relay;

### Relay Control

Manual raise / lower commands & resetting functions can be performed;

### Commissioning

To export reports of setting parameters & status screen to confirm correct functionality during commissioning;

### Upgrade relay software

To configure a  $\mu$ MATRIX relay for a specific customer application;

To upgrade the operational software (UMX) of a  $\mu$ MATRIX relay;

All current UMX software applications may be downloaded from:

[www.rmspl.com.au/umatrix](http://www.rmspl.com.au/umatrix)

### Maintenance

To provide utility and diagnostic facilities at a technical level.

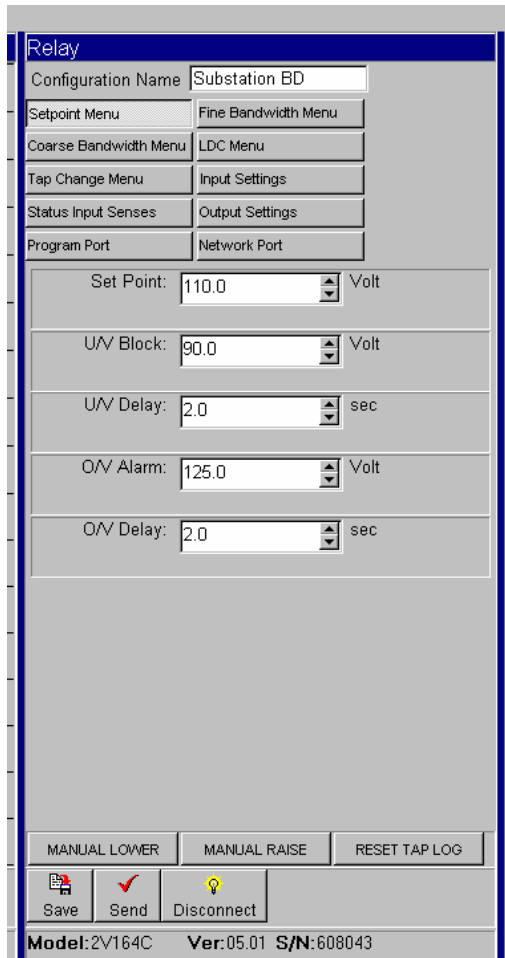

## PORTS

Two (2) communications ports are available.

### Programming port

The programming port is accessible from the front panel of the relay via an RS232 physical link & PC configuration program supplied with the relay. The  $\mu$ MATRIXwin configuration program is designed to operate with all relays from the Micro MATRIX range & with all installed firmware version.

### Network port

The network port is intended for applications where permanent connection to a master control system is required. An optically isolated RS232 or RS485 physical layer is provided for this function.

The RS485 connection is intended for applications where multiple  $\mu$ MATRIX relays are to be connected on a common communications bus.

The RS232 connection is intended for interface to an RS232 to optic fiber converter in environments subject to extreme electrical interference.

The network port may be used for a permanent link to a modem, remote PC, data concentrator or SCADA system. The standard communications protocol is MODBUS RTU.

### Changing the Network port from RS485 to RS232

$\mu$ MATRIX relays are shipped with the rear network port terminals configured as RS485. This configuration may be changed in the field to RS232 if required by withdrawing the relay module from the case & changing the three configuration links as depicted.

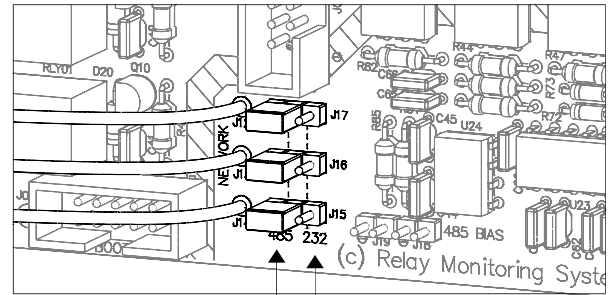

RS485 Port Header Position

RS232 Port Header Position

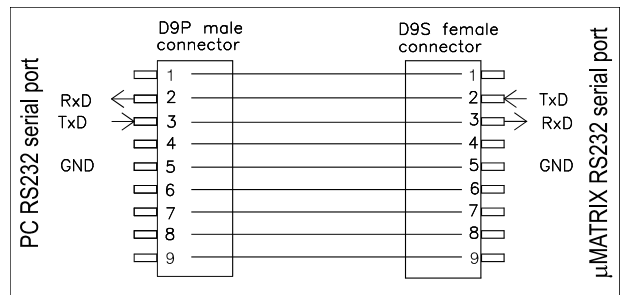

### **PC TO $\mu$ MATRIX SERIAL CABLE**

One cable supplied with each order.  
P/N 290-406-151



# Technical Data

## VOLTAGE SENSING CIRCUITRY

Nominal monitoring voltage: 110V 50HZ for IN QUAD connection  
63.5V 50Hz for IN PHASE connection

Sensing supply burden: Less than 1VA

DC Input resistance: 63.5V tap: 227 Ohm  
110V tap: 626 Ohm

Nominal sensing frequency: 40 to 60Hz

### Voltage measurement secondary accuracy (110V tap):

Precision of voltage setting: 0.1V steps  
Voltage pick up repeatability: +/-0.1V from 90 to 120V  
Voltage measurement resolution: 45mV  
Resolution of voltage display: 0.1V  
Accuracy of displayed voltage: +/-0.1V from 90 to 120V

## LINE DROP COMPENSATION (LDC) INPUT

Nominal sensing current: CT taps for 1A & 5A inputs  
LDC accuracy: +/- 0.3V error at nominal 110V setting & 10 to 110% CT input

Burden: VA all settings.

I amps	1A CT input	5A CT input
0.5	0.014	-
1	0.06	0.008
1.5	0.13	-
2	0.22	0.034
2.5	0.34	-
3	0.49	-
3.5	0.67	-
4	0.87	-
4.5	1.1	-
5	1.4	0.3
7	2.6	0.5
9	4.0	0.7
12	6.5	1.3
15	9.5	2.0
20	15	3.5
25	21	5.4

Thermal Withstand:

	1A CT	5A CT *
Continuous	5	25
4.5s	20	240
3s	40	450
2s	50	550
1s	70	800
0.5s	100	1,100

Note: \* M Series case terminals & CT shorting switches are limited to 400A for 1s.

## TAP CHANGE FEEDBACK FUNCTION

When a tap change command is output to the OLTC, the tap change fail timer is started. If a single tap change restores the sensed voltage to a balanced condition the relay is reset. If the sensed voltage remains in error the interval time delay will start based on one of the three methods described below: The required operating mode is selected using the UMX order code.

### VOLTAGE MONITORING (Automatic mode) UMX2V164A

In this mode the 2V164 provides a 1s output pulse to initiate a tap change. This output pulse is then repeated at a rate set by the Interval Timer setting until the sensed voltage has moved back to a balanced condition. This is the simplest connection method as it does not require a hard-wired contact between the OLTC & the VRR.

The output pulse may be selected as continuous for application with linear voltage regulators. The continuous output contact & interval timer delay is reset once the sensed voltage moves back to the balanced condition.

### OLTC AUXILIARY CONTACT METHOD UMX2V164B

In this mode an auxiliary contact on the OLTC is employed to signal completion of a tap change sequence. This signal is used by the 2V164 to pause the interval time delay until the previous tap change sequence has been completed.

The default 2V164 T/C feedback status input is set for a control voltage to be removed when the tap change starts (OLTC auxiliary contact opens) & re-applied when the tap change sequence is completed (OLTC auxiliary contact closes). The interval time delay is paused until the completion of the tap change sequence has been signalled.

The output pulse may be selected as continuous or to provide a 1s pulse output.

The continuous output contact & interval time delay is reset once the sensed voltage moves back to a balanced condition.

### TPI FEEDBACK METHOD UMX2V164C

In this mode the 2V200 TPI transducer must be connected as per figure 2. The control sequence is as follows:

1. A voltage deviation starts the initial time delay.
2. The time delay expires & a tap change command is output.
3. The tap change contact will remain closed until a signal is received from the TPI transducer confirming that a tap change event has occurred.
4. The interval time delay is initiated.
5. Sequence 2 to 4 will repeat at the rate determined by the Interval timer setting until the sensed voltage has moved back to a balanced condition.

## LINE VOLTAGE ANALOGUE OUTPUT

Output: 4 to 20mA  
Compliance voltage: 5V  
Maximum burden: 250 Ohms  
Accuracy: +/-3%  
Analogue output: Lower (4mA) set point range: 0V - 146V  
Upper (20mA) set point range: 50V - 146V



Visit [www.rmspl.com.au](http://www.rmspl.com.au) for the latest product information.

Due to RMS continuous product improvement policy this information is subject to change without notice. 2V164/Issue S/17/11/08 - 5/8

### AUXILIARY SUPPLY

20-70V DC switchmode supply or  
40-275V AC / 40-300V DC switchmode supply

Burden: Less than 10 watts with all output relays energized using 110V DC nominal supply.

#### Inputs:

A high efficiency switchmode power supply is incorporated which provides a low burden to the auxiliary supply.

#### Input Transients:

Withstands multiple high-energy transients & ring waves in accordance with IEEE28 - ANSI C26.1 Cat. II, accordingly:

- 0.5uS 100KHz      6KV O/C, 500A S/C, 4J
- 1.2/50uS          6Kv O/C
- 8/20uS             3KA S/C, 80J clamped at 1,000V

Mains conducted EMI within limits specified by AS 3548 Class B.

#### Isolation:

The inputs are isolated from the outputs in accordance with AS3260 Class II Limited Current Circuitry, accordingly:

- Withstand voltage of 2.5Kv RMS 50Hz for one minute
- Creepage & clearance distance greater than 4mm
- Output leakage current less than 0.25A to earth

#### Output Protection:

Outputs will withstand continuous short circuit. Output regulators & switching control regulator are thermally protected.

### RELAY FAIL ALARM

A C/O alarm contact is maintained in the energized state when all of the following conditions are met:

- The auxiliary supply is applied
- The internal 24V DC rail is within acceptable limits
- The CPU hardware watchdog maintains a pulsing output

A CPU software watchdog records "suspect" events to an assert register & if necessary performs a soft restart.

A front panel green LED is illuminated when the relay is healthy. A separate flashing red LED indicates a software problem has been encountered which caused causing the CPU to perform a warm boot.

### OPERATING TEMPERATURE RANGE

-5 to +55 degrees Celsius ambient operating temperature range.

### HUMIDITY

40 degrees C & 95% RH non condensing

### CASE

Size 4 draw out  
56 M4 screw terminals  
Flush panel mount or 4U high 1/4 width 19 inch rack mount  
IP51 rating

### OUTPUT CONTACT RATINGS

#### Make & carry

30A AC or DC (Limits L/R=40ms & 300V max.) for 0.2s  
20A AC or DC (Limits L/R=40ms & 300V max.) for 0.5s  
5A AC or DC continuously

#### Break (Limits 5A & 300V max.)

1,250VA AC resistive  
250VA at 0.4PF AC inductive  
75W DC resistive  
30W DC inductive L/R = 40ms  
50W DC inductive L/R = 10ms

#### Minimum recommended load

0.5W, 10mA or 5V minimum.

### INSULATION WITHSTAND

IEC60255-5      2KV RMS & 1.2/50 5KV impulse between:

- ◆ all input terminals & frame
- ◆ all output terminals & frame
- ◆ all input & output terminals
- ◆ each input group
- ◆ each output group

Across open contacts:      1KV RMS

### HIGH FREQUENCY DISTURBANCE

IEC60255-22-1      2.5KV 1MHz common mode  
1.0KV 1MHz differential mode

### ELECTROSTATIC DISCHARGE

EN61000-4-2:1995 8KV      Level 3

### RADIO FREQUENCY INTERFERENCE

EN61000-4-3:1995 10V/m      Level 3

### FAST TRANSIENT DISTURBANCE

EN61000-4-4:1995 4KV      Level 4

### SHIPPING DETAILS

Each relay is supplied individually packed in pre formed cardboard cartons with internal moulded polystyrene former.

Weight: 4Kg

Size: 370(L) x 240(W) x 145(D)mm - Size 4 case

For large shipment individual cartons are packed in sturdy cardboard pallet boxes & surrounded by loose fill to absorb vibration & shock during transit.

### ACCESSORIES SUPPLIED WITH EACH RELAY

- 1 x M4 self threading mounting screw kit      P/N 290-406-151
- 2 x M4 terminal screw kit (28 per kit)      P/N 290-407-153
- 1 x  $\mu$ MATRIX User Guide per order
- 1 x CD of  $\mu$ MATRIXwin software, setting files & applications

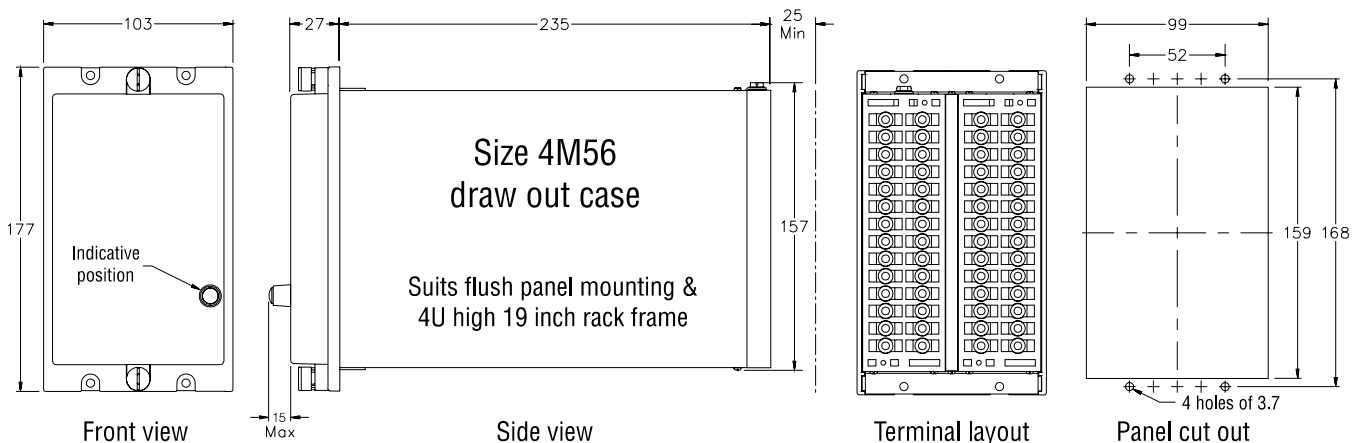

## In QUAD Connection

Tap change feedback control mode depicted

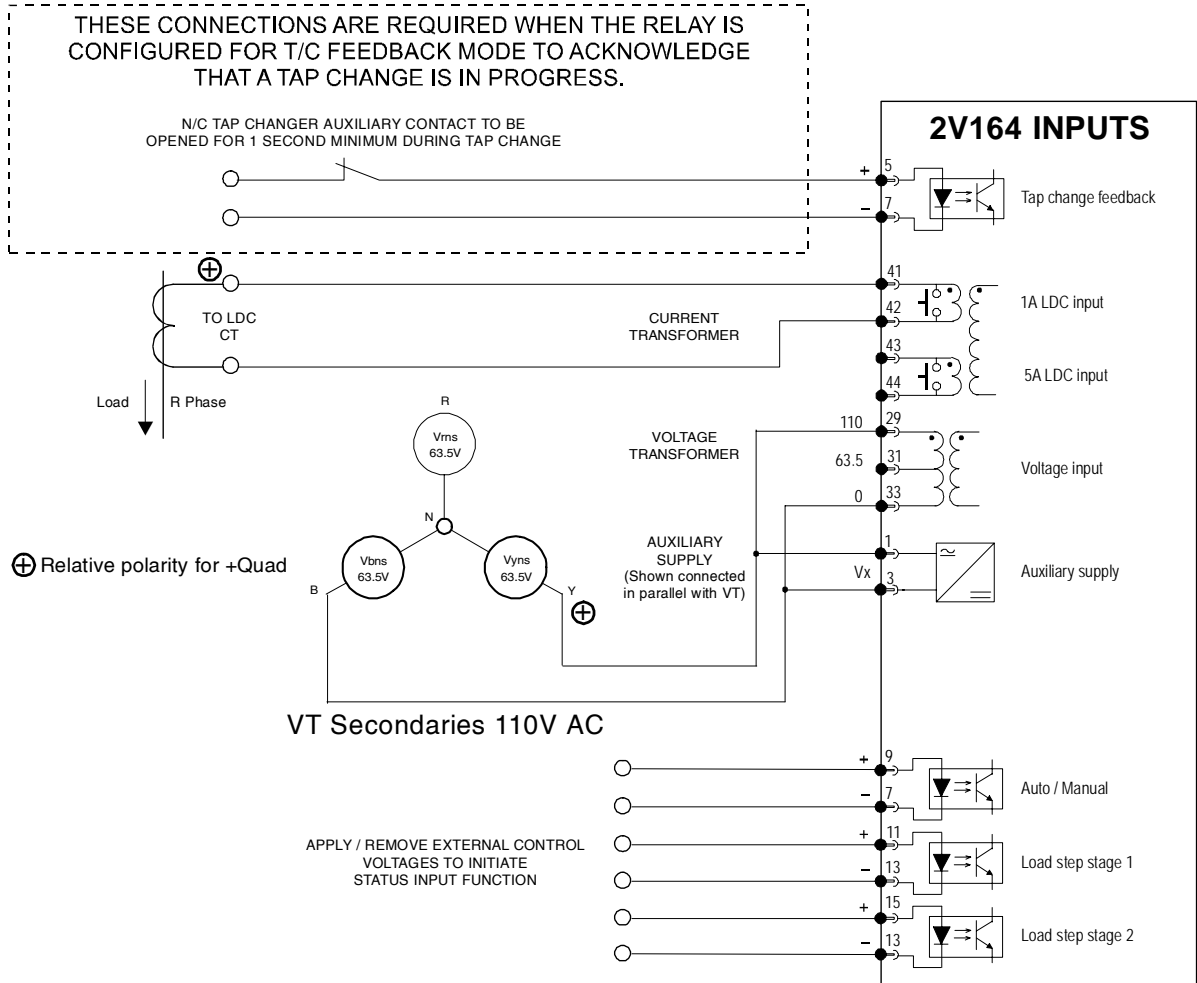

## In PHASE Connection

Auto or TPI mode for tap change feedback control

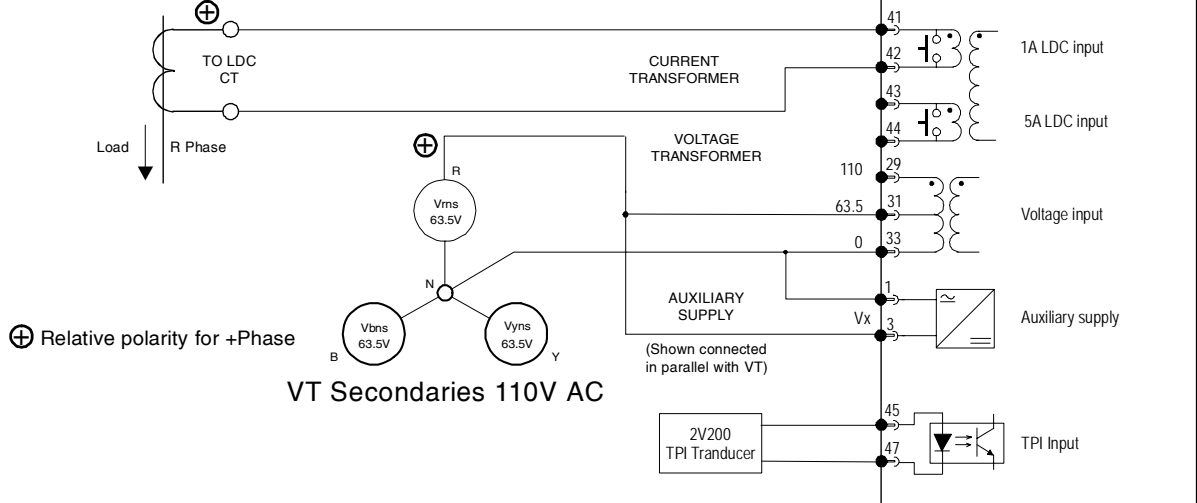

2V164 application diagram

All relay contacts are shown with a healthy supply applied, the 2V164 in a balanced condition, auxiliary supply connected in parallel with the 110V sensed voltage & 1 Amp CT tap LDC input wired.

# Ordering Information

Generate the required ordering code as follows: e.g. 2V164 BBBA

2V164 1 2 3 4

## 1 AUXILIARY SUPPLY RANGE

- A 20-70V DC
- B 40-300V DC / 40-275V AC

## 2 DIGITAL INPUT OPERATING VOLTAGE – GROUP 1

Opto-isolated input

- A 24-80V AC/DC
- B 75-150V AC/DC
- C 150-300V AC/DC

## 3 DIGITAL INPUT OPERATING VOLTAGE – GROUP 2

Opto-isolated input

- A 24-80V AC/DC
- B 75-150V AC/DC
- C 150-300V AC/DC

## 4 ANALOGUE OUTPUTS

- A Not required
- B Required 4 to 20mA

## ! SELECT DEFAULT APPLICATION SOFTWARE

- A UMX2V164A Voltage monitoring feedback – Auto mode
- B UMX2V164B OLTC auxiliary contact method
- C UMX2V164C TPI feedback method

Where the tap position is to be displayed on the 2V164 refer to the 2V200 TPI Transducer Technical Bulletin for ordering information.

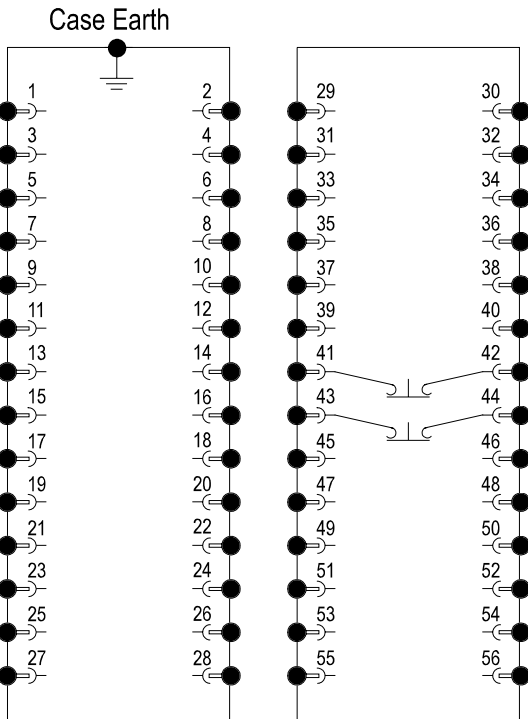

4M56 Case terminations (REAR VIEW)

\*Note: The status inputs & some relay outputs are assigned by the software (UMX) loaded on the relay.

Shown here are the standard assignments of the A, B, C UMXs. Other UMX versions may differ. Consult the UMX data sheets for specific I/O assignments.

FRONT PANEL  
PC PROGRAMMING  
PORT

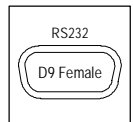

One DE09 straight through male to female  
2 metre connection cable supplied  
with each order of relays  
(P/N 997-000-042B)

SCADA  
COMMUNICATIONS  
PORT  
(Use one only)

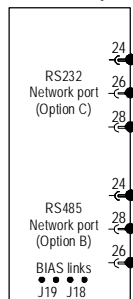

Dedicated  
supervisory connection

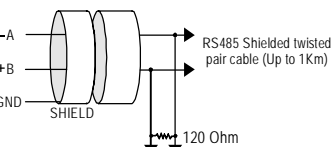

To other uMATRIX relays (Up to 32 units)  
Fit external terminating resistor to end of BUS relay only  
Fit internal BIAS jumper links for single relay connection only

2V164 wiring diagram\* - Relays shown in de-energised condition

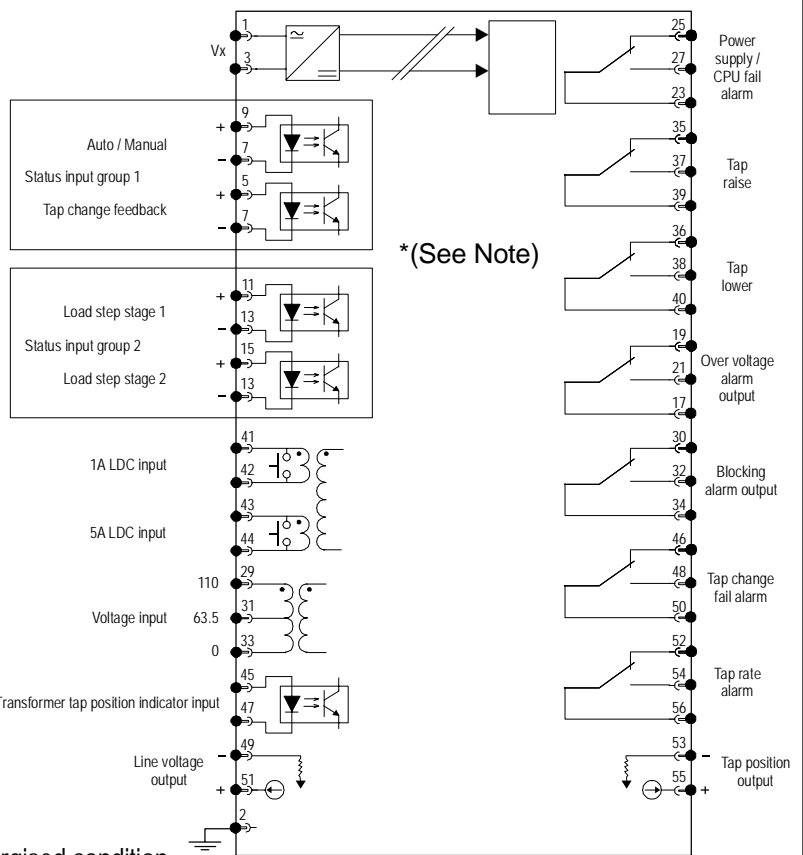

\*(See Note)

## **Australian Content**

Unless otherwise stated the product(s) quoted are manufactured by RMS at our production facility in Melbourne Australia. Approximately 60% of our sales volume is derived from equipment manufactured in house with a local content close to 90%. Imported components such as semi-conductors are sourced from local suppliers & preference is given for reasonable stock holding to support our build requirements.

## **Quality Assurance**

RMS holds NCSI (NATA Certification Services International), registration number 6869 for the certification of a quality assurance system to AS/NZS ISO9001-2000. Quality plans for all products involve 100% inspection and testing carried out before despatch. Further details on specific test plans, quality policy & procedures may be found in section A4 of the RMS product catalogue.

## **Product Packaging**

Protection relays are supplied in secure individual packing cardboard boxes with moulded styrene inserts suitable for recycling. Each product & packing box is labeled with the product part number, customer name & order details.

## **Design References**

The products & components produced by RMS are based on many years of field experience since Relays Pty Ltd was formed in 1955. A large population of equipment is in service throughout Australia, New Zealand, South Africa & South East Asia attesting to this fact. Specific product & customer reference sites may be provided on application.

## **Product Warranty**

All utility grade protection & auxiliary relay products, unless otherwise stated, are warranted for a period of 24 months from shipment for materials & labour on a return to factory basis. Repair of products damaged through poor application or circumstances outside the product ratings will be carried out at the customer's expense.

## **Standard Conditions of Sale**

Unless otherwise agreed RMS Standard Terms & Conditions (QF 907) shall apply to all sales. These are available on request or from our web site.



## **Relay Monitoring Systems Pty Ltd**

6 Anzed Court, Mulgrave, Victoria 3170, AUSTRALIA

Tel: 61 3 9561 0266 Fax: 61 3 9561 0277 Email: [rms@rmspl.com.au](mailto:rms@rmspl.com.au) Web: [www.rmspl.com.au](http://www.rmspl.com.au)