

Features

- AC & DC input versions
- Heavy duty output contacts with optional magnetic arc blowouts
- Select number & type of output contacts
- Self reset LED P/U indication
- Optional hand or self reset mechanical flag
- Simple & proven circuit design
- Fixed or adjustable pick up
- Fixed or adjustable drop out
- May be used in under or over voltage monitoring
- Custom contact arrangement possible
- Self powered from voltage sensing input
- Size 2M28-S or 4M28-S draw out case

Application

The 2V63 series voltage monitoring relays may be applied to a wide range of protection & control functions.

The relay may be set for over voltage operation such that the output contact pick up when the pre set voltage level is exceeded.

Alternatively the relay may be set for under voltage operation such that the output contacts are normally picked up & will drop out when the monitored voltage fall below the drop out level.

Setting Options

Refer order code 6.

- A Adjustable drop out & fixed pick up
- B Adjustable pick up & fixed drop out
- C Adjustable pick up & drop out
- D Fixed pick up & drop out

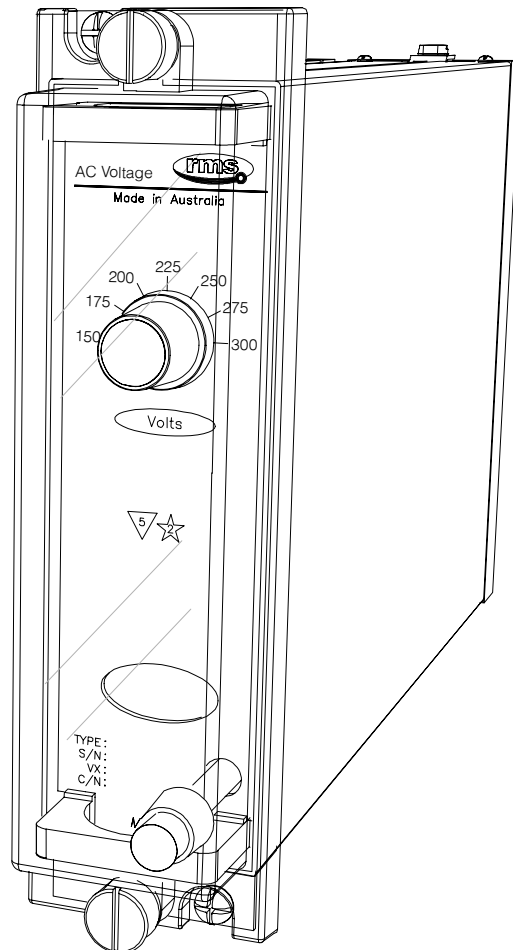

2V630 depicted in a 2M28 case

Description

Made in Australia

The 2V630 / 2V631 series are solid state voltage sensing relays with electromechanical output contacts built in a fully draw out case format. Designed for application on AC & DC voltage systems, these relays are ideally suited to monitor power supply voltage levels wherever high accuracy and reliable, maintenance free operation is essential.

All power to operate the relays is derived from the sensed input voltage therefore an auxiliary supply is not required. The output relay operates when the input voltage exceeds the pickup setting (P/U) and visual indication is proved by a hand reset mechanical flag or self reset red LED on the front panel.

The output relay will reset when the input voltage drops below the drop out voltage (D/O). The relay may be ordered with a pre-set fixed D/O level or as an adjustable setting value displayed as a percentage of the selected pickup voltage.

- ◆ The 2V630 version is designed for AC 50 or 60Hz voltage operation
- ◆ The 2V631 version is designed for DC voltage operation

2V630 AC Version

VOLTAGE PICK UP RANGES

Adjustable versions:

Range A:	15 to 30V AC
Range B:	30 to 60V AC
Range C:	75 to 150V AC
Range D:	150 to 300V AC
Range E:	300 to 600V AC

Fixed setting versions:

Specify setting with order code – 15 to 600V AC

OPERATING FREQUENCY

50 or 60Hz

DROP OUT VOLTAGE

Fixed setting version: 85% of pick up – Default setting
Specify custom setting with order code

Adjustable setting version: 75 - 98% of pick up all ranges

OPERATE TIMES (Typical)

Pick up: 200 to 800ms across pickup range
Drop out: 200 to 600ms across dropout range

AUXILIARY POWER SUPPLY

Self powered from sense input

SETTING ACCURACY

+/-5% of full scale

POWER CONSUMPTION

5VA maximum

MAXIMUM WITHSTAND

Continuous: 125% of maximum setting
For 3s: 175% of maximum setting

2V631 DC Version

VOLTAGE PICK UP RANGE

Adjustable versions:

Range F:	15 to 30V DC
Range G:	30 to 60V DC
Range H:	75 to 150V DC

Fixed setting versions:

Specify setting with order code – 15 to 150V DC

DROP OUT VOLTAGE

Fixed setting version: 85% of pick up – Default setting
Specify custom setting with order code

Adjustable setting version: 75 - 98% of pick up all ranges

OPERATE TIMES (Typical)

Pick up: 200 to 800ms across pickup range
Drop out: 200 to 600ms across dropout range

AUXILIARY POWER SUPPLY

Self powered from sense input

SETTING ACCURACY

+/-5% of full scale

POWER CONSUMPTION

5VA maximum

MAXIMUM WITHSTAND

Continuous: 125% of maximum setting
For 3s: 150% of maximum setting
Absolute maximum limit: 400V DC for 3s

CONTACTS

3 C/O contacts standard.
Additional contacts may be specified – refer factory.

6R RELAY CONTACT RATINGS

Make & Carry Continuously

3,000 VA AC resistive with maximums of 660V & 12A
3,000 W DC resistive with maximums of 660V & 12A

Make & Carry for 3 Seconds

7,500 VA AC resistive with maximums of 660V & 30A
7,500 W DC resistive with maximums of 660V & 30A

AC Break Capacity

3,000 VA AC resistive with maximums of 660V & 12A

DC Break Capacity (Amps)

Voltage			24V	48V	125V	250V
Resistive rating		a	12	1.5	0.5	0.25
		b	12	12	10	5
L/R=40ms	Maximum break	a	12	1	0.25	0.15
		b	30	15	5.5	3.5
1K operations (N3 Rating)		b	12	12	5	2.5

a = Without magnetic blowouts b = With magnetic blowouts

AMBIENT OPERATING TEMPERATURE RANGE

-5 to 55 degrees C.

INSULATION WITHSTAND

IEC60255-5 2KV RMS & 1.2/50 5KV impulse between:

- ◆ all input terminals & frame
- ◆ all output terminals & frame
- ◆ all input & output terminals
- ◆ each input group
- ◆ each output group

HIGH FREQUENCY DISTURBANCE

IEC60255-22-1 2.5KV 1MHz common mode
1.0KV 1MHz differential mode

ELECTROSTATIC DISCHARGE

EN61000-4-2:1995 8KV Level 3

FAST TRANSIENT DISTURBANCE

EN61000-4-4:1995 4KV Level 4

CASE

28 M4 screw terminals

IP5x rating

Single element versions

Size 2M28-S draw out case

Flush panel mount or 4U high 1/8 width 19 inch rack mount

Dual element versions

Size 4M28-S draw out case

Flush panel mount or 4U high 1/4 width 19 inch rack mount

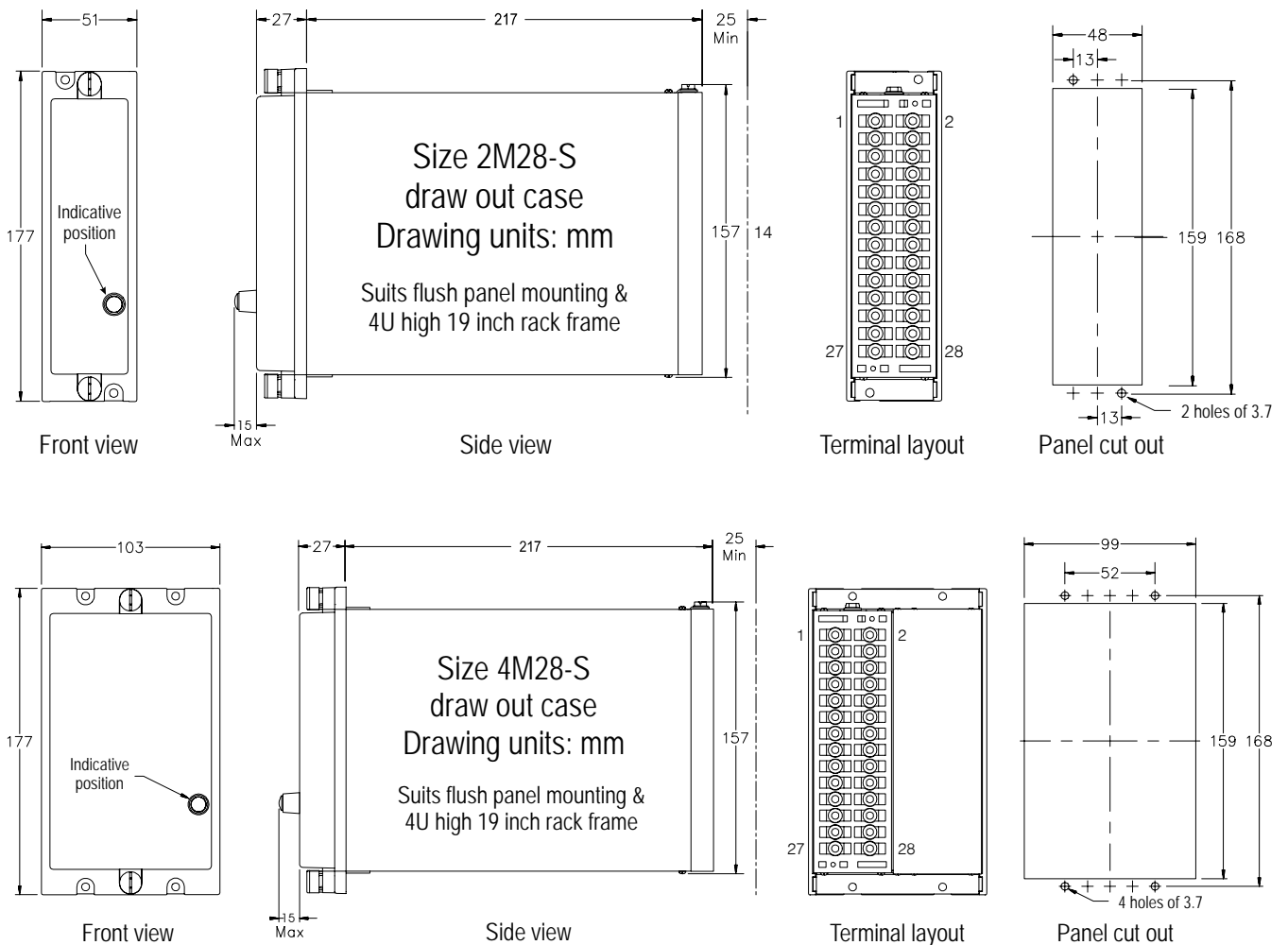

Ordering Information

Generate the required ordering code as follows:
e.g. 2V631 – HAABB [120]

2V63 M - 1 2 3 4 5

M MONITORED VOLTAGE

- 0 AC (50 or 60Hz)
- 1 DC

1 VOLTAGE PICK UP RANGE

2V630	2V631
A 15 to 30V AC	F 15 to 30V DC
B 30 to 60V AC	G 30 to 60V DC
C 75 to 150V AC	H 75 to 150V DC
D 150 to 300V AC	
E 300 to 600V AC	

2 CASE CONFIGURATION

- A One element in a size 2M28 case
- B Two elements in a size 4M28 case

3 OUTPUT CONTACTS

- A Heavy duty 6R contacts
- B Heavy duty 6R contacts with magnetic blowouts

4 FLAG INDICATOR

- A Not required (Self reset LED fitted)
- B Hand reset flag operates on pick up (2F)
- C Hand reset flag operates on drop off (3F)
- D Self reset flag operates on pick up (4F)
- E Self reset flag operates on drop off (5F)

5 VOLTAGE PICK UP & DROP OUT SETTING

- A Adjustable voltage drop out setting & fixed pick up: [] V
- B Adjustable voltage pick up setting & fixed drop out: [] %
- C Adjustable voltage pick up & drop out setting (LED flag only)
- D Fixed voltage pick up setting: [] V & drop out: [] %

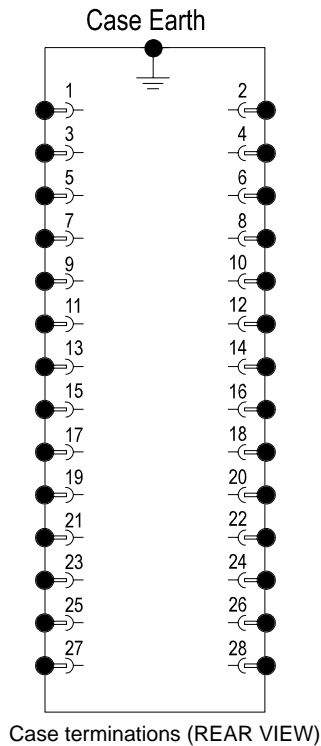

One element per case

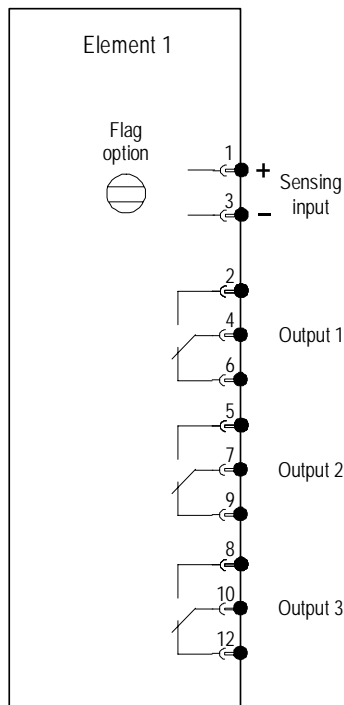

Two elements per case

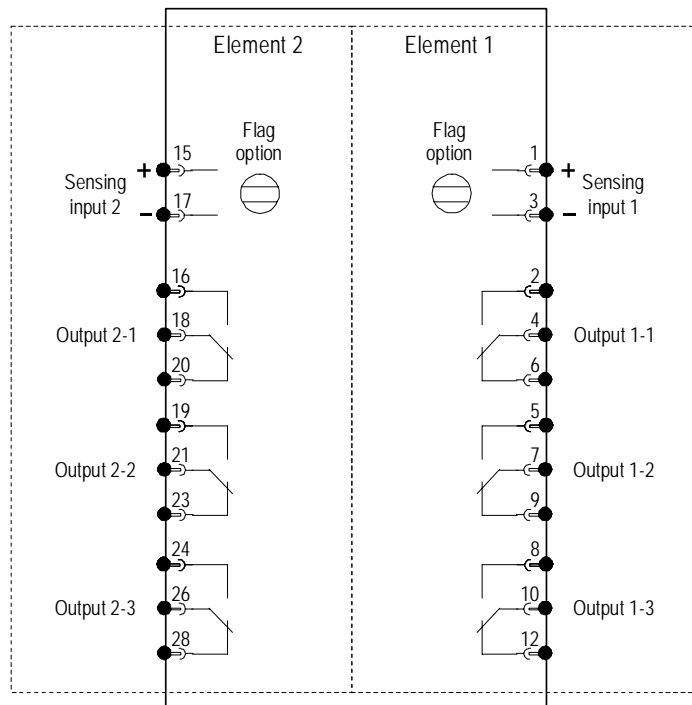

2V63 wiring diagram - All contacts shown in de-energised state (FRONT VIEW)

Australian Content

Unless otherwise stated the product(s) quoted are manufactured by RMS at our production facility in Melbourne Australia. Approximately 60% of our sales volume is derived from equipment manufactured in house with a local content close to 90%. Imported components such as semi-conductors are sourced from local suppliers & preference is given for reasonable stock holding to support our build requirements.

Quality Assurance

RMS holds NCSI (NATA Certification Services International), registration number 6869 for the certification of a quality assurance system to AS/NZS ISO9001-2008. Quality plans for all products involve 100% inspection and testing carried out before despatch. Further details on specific test plans, quality policy & procedures may be found in section A4 of the RMS product catalogue.

Product Packaging

Protection relays are supplied in secure individual packing cardboard boxes with moulded styrene inserts suitable for recycling. Each product & packing box is labeled with the product part number, customer name & order details.

Design References

The products & components produced by RMS are based on many years of field experience since Relays Pty Ltd was formed in 1955. A large population of equipment is in service throughout Australia, New Zealand, South Africa & South East Asia attesting to this fact. Specific product & customer reference sites may be provided on application.

Product Warranty

All utility grade protection & auxiliary relay products, unless otherwise stated, are warranted for a period of 24 months from shipment for materials & labour on a return to factory basis. Repair of products damaged through poor application or circumstances outside the product ratings will be carried out at the customer's expense.

Standard Conditions of Sale

Unless otherwise agreed RMS Standard Terms & Conditions (QF 907) shall apply to all sales. These are available on request or from our web site.



Relay Monitoring Systems Pty Ltd

6 Anzed Court, Mulgrave, Victoria 3170, AUSTRALIA

Tel: +61 3 8544 1200 Fax: +61 3 8544 1201 Email: rms@rmspl.com.au Web: www.rmspl.com.au