

## Features

- High speed operation
- High sensitivity
- Wide range of settings
- High stability
- 25-115V & 25-325V versions
- 50Hz & 60Hz versions
- Insensitive to DC
- Hand reset mechanical flag
- Optional remote reset flag
- Rugged attracted armature sensing elements
- Use 3 independent units for 3 phase applications
- Size 2M draw out case

## Application

The 2V73 relay provides high speed differential protection for various items of power system plant including generators, busbars, motors & the individual windings of power transformers. It is also suitable for restricted earth fault protection applications.

When circulating current protection schemes are subjected to sudden & often asymmetrical growth in system currents due to through faults, the line current transformers can quickly reach saturation. In this condition, variation in transformer magnetizing characteristics can cause large ratio errors with a consequent circuit imbalance & false tripping of the protective relay scheme.

In order to ensure protection stability, a high impedance differential relay set to operate at a slightly higher voltage than that developed in the worst case of the above condition for a through fault current may be used. On a balanced earth fault system for example, this is when one CT of a group is saturated while the others remain unaffected. The saturated CT presents a low impedance path in parallel with the relay, which effectively limits the voltage applied to avoid operation. On internal faults however, this limitation does not exist & voltages of twice the relays pick up settings are easily reached.

The 2V73 relay is a single phase device built in a compact size 2M draw out case suitable for rack and flush mounting. Where 3 phase monitoring is required, 3 single phase units should be employed.

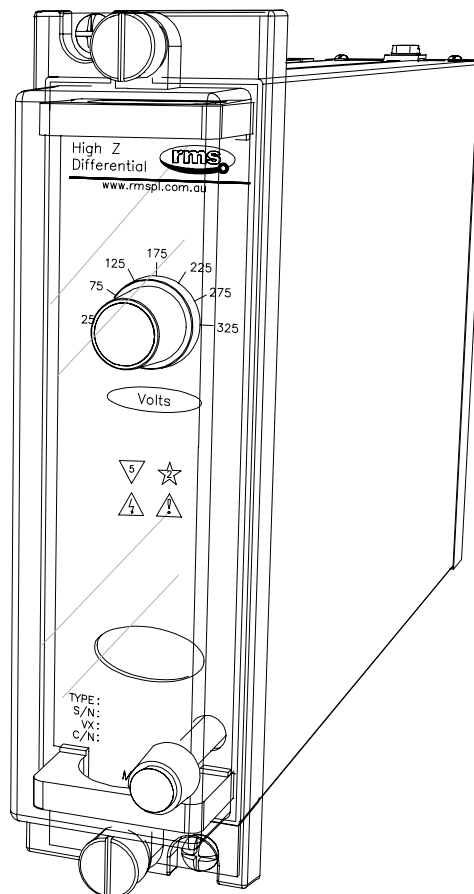

2V73 depicted in a 2M28 case

## Operation

Made in Australia

The relay measuring element is basically an attracted armature unit of simple & rugged construction powered from a bridge rectifier. The relay can be set in steps (25-115V in 15V steps or 25-325V in 50V steps), by using the front panel mounted selector switch. A capacitor is connected in series with the operating coil to make the relay insensitive to the DC component of fault current. The setting can thus be calculated in terms of RMS AC quantities without regard for the degree of offsets produced by the point on wave at which the fault occurs. An inductor connected in series with the capacitor forms a resonant circuit tuned to the relays rated frequency.

An external Metrosil unit having a non-linear resistance characteristic is required for each phase element to limit the peak voltage appearing across the secondary differential circuits under internal fault conditions. The type of Metrosil characteristic required is dependant on the relay setting range. For AC applications the following equation can be used to determine an approximate AC characteristic:

$$V = 0.84 C (I)^B$$

V = RMS voltage, I = RMS Amps, C & B are fixed constants for the selected Metrosil. For the setting range of 25 to 325V a Metrosil with nominal C = 1,000 & B = 0.22 is suitable to provide a 400V continuous rating & current overload short time rating as follows: 15A for 3s, 21A for 2s & 37A for 1s.

### RELATED EQUIPMENT

- ◆ Refer to the 2V75 Technical Bulletin for details on the RMS Metrosil modules;
- ◆ Refer to the 1M123 & 1M124 Technical Bulletin for details on complete BUS protection rack solutions;
- ◆ Refer to the 2V68 Technical Bulletin for details on CT supervision applications;
- ◆ The 2V73 is a voltage operated relay. For a current operated version refer to the 2C73 Technical Bulletin.



# Technical Data

### DERIVED RELAY POWER

During internal fault conditions, the relay & Metrosil current & the magnetizing current of all the connected CT's is supplied from the fault current.

### EFFECTIVE OPERATING CURRENT

The primary operating current is given by:  $I_{op} = n (I_R + N I_O)$

$I_R$  = Relay operating current & Metrosil current at setting voltage as per the table below.

$I_O$  = CT magnetizing current at setting voltage (A)

$n$  = CT turns ratio

$N$  = Number of connected CT's

The operating currents shown in the following tables are for both 3 inch & 6 inch Metrosil's connected to the 2V73 as per the wiring diagram.

Range A (Volts)	25	75	125	175	225	275	325
Nominal (mA)	15	15	15	15	17	21	29
Limits (mA)	13	13	13	13	13	15	18
	to	to	to	to	to	to	to
	16	17	17	20	27	39	61

Range B (Volts)	25	40	55	70	85	100	115
Nominal (mA)	14	14	14	14	14	14	14
Limits (mA)	13	13	13	13	13	13	13
	to	to	to	to	to	to	to
	16	16	16	17	17	17	17

Should the natural effective operating current after applying the above formula be lower than that desired, it can be raised to the required level by adding a shunt resistor across the differential relay input circuit.

### SELECTION OF OPTIMUM RELAY SETTING

The required relay setting ( $V_s$ ) is calculated using the following formula:

$$V_s = \frac{I_f}{n} (R_{ct} + 2 R_w) \text{ Volts}$$

$I_f$  = Max. primary through fault current for which stability is required (RMS Amps)

$n$  = CT turns ratio

$R_{ct}$  = CT secondary winding resistance (Ohms)

$R_w$  = Resistance of each lead between the relay & CT (Ohms)

A value of  $V_s$  is calculated for each CT circuit in the differential system, & the relay setting finally chosen above the highest of these calculated values.

### RECOMMENDED METROSIL's (Refer 2V75 Technical Bulletin)

Type	Specification	Rated Energy	Part No.
6" 3 $\phi$	600A/S3/I/S887	33kJ	2105C58001
6" 1 $\phi$	600A/S1/S887	33kJ	2105C58002
3" 3 $\phi$	300A/S3/I/S3063	8kJ	2105C58006
3" 1 $\phi$	300A/S1/S646	8kJ	2105C58004

### CURRENT TRANSFORMERS (CT's)

The 2V73 type relay is suitable for use with 0.5A, 1A & 5A CT's at 50 or 60Hz. The CT's used in circulating current differential protection systems must be of equal turns ratio & have a reasonably low secondary winding resistance. The CT knee point voltage (Point on magnetization curve at which a 10% increase in excitation voltage produces a 50% increase in excitation current) should be at least twice the voltage setting.



**SETTING RANGE**

25-325V AC in 50V steps  
25-115V AC in 15V steps

**FREQUENCY**

Specify 50Hz or 60Hz operation

**OUTPUT RELAY OPERATION INDICATOR**

Hand reset mechanical indicator.

**REMOTE RESET FLAG OPTION**

No auxiliary is required when the hand reset mechanical flag is specified. To facilitate remote flag resetting, a magnetic type flag may be specified which requires a separate auxiliary for the flag to set & reset to function. This auxiliary is low burden & must be continuously applied to the flag auxiliary input.

Magnetic flag reset operating range:

Specify: 24 to 150V DC or  
140 to 300 V DC

**PICK UP ACCURACY**

+/-10% of setting & +/-3V on the 25V setting.

**OUTPUT RELAY CONTACTS**

2 N/O

**OPERATE TIMES**

Pick up: <20ms at 4 times  $V_s$   
Drop out: <50ms

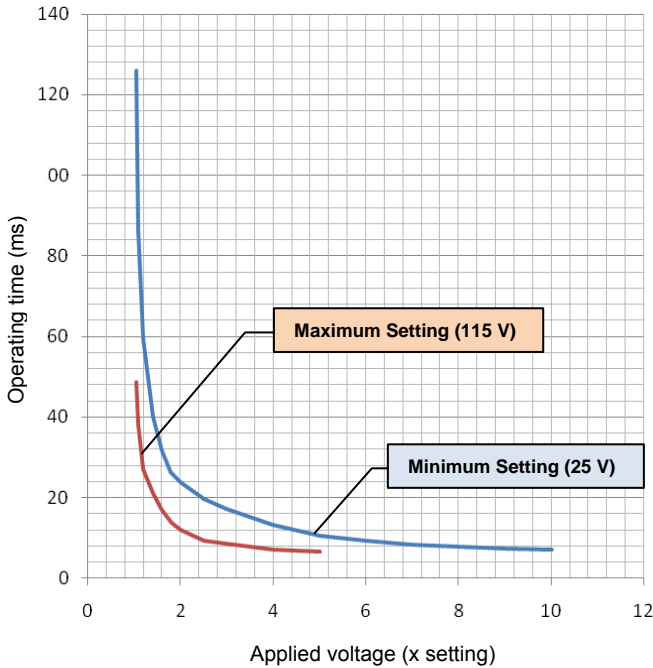

Figure 1 – 2V73 Operating Characteristic

**Technical Data**

**THERMAL WITHSTAND – RELAY ALONE**

Range	Continuous	1s
25-175V	2 x setting	8x setting
25-325V	1.5 x setting	6x setting

**6R RELAY CONTACT RATINGS**

**Make & Carry Continuously**

3,000 VA AC resistive with maximums of 660V & 12A  
3,000 W DC resistive with maximums of 660V & 12A

**Make & Carry for 0.5 Seconds**

7,500 VA AC resistive with maximums of 660V & 30A  
7,500 W DC resistive with maximums of 660V & 30A

**AC Break Capacity**

3,000 VA AC resistive with maximums of 660V & 12A

**DC Break Capacity (Amps)**

Voltage		24V	48V	125V	250V
Resistive rating		12	1.5	0.5	0.25
L/R=40ms	Maximum break *	12	1	0.25	0.15

**TRANSIENT OVERVOLTAGE**

Between all terminals & earth  
Between independent circuits without damage or flashover

**IEC60255-5 CLASS III**

5kV 1.2/50us 0.5J  
5kV 1.2/50us 0.5J

**INSULATION COORDINATION**

Between all terminals & earth  
Between independent circuits  
Across normally open contacts

**IEC60255-5 CLASS III**

2.0kV RMS for 1 minute  
2.0kV RMS for 1 minute  
1.0kV RMS for 1 minute

**HIGH FREQUENCY DISTURBANCE**

2.5kV 1MHz common mode  
1.0kV 1MHz differential mode

**IEC60255-22-1 CLASS III**

≤ 3% variation

**ELECTROSTATIC DISCHARGE**

6kV contact discharge

**IEC60255-22-2 CLASS III**

≤ 5% variation

**RADIO FREQUENCY INTERFERENCE**

10V/m, 80 TO 1,000MHz

**IEC60255-22-3**

≤ 5% variation

**FAST TRANSIENT**

4kV, 5/50ns, 2.5KHz repetitive

**IEC60255-22-4**

≤ 3% variation

**CONDUCTED RFI**

10V, 0.15 to 80MHz

**IEC60255-22-6**

≤ 5% variation

**TEMPERATURE RANGE**

Operating:  
Storage:

**IEC68-2-1/2**

-5 to +55°C  
-25 to +75°C

**HUMIDITY**

40°C & 95% RH non condensing

**IEC68-2-78**

High impedance differential protection application  
(Use 3 units for 3 phase configuration)

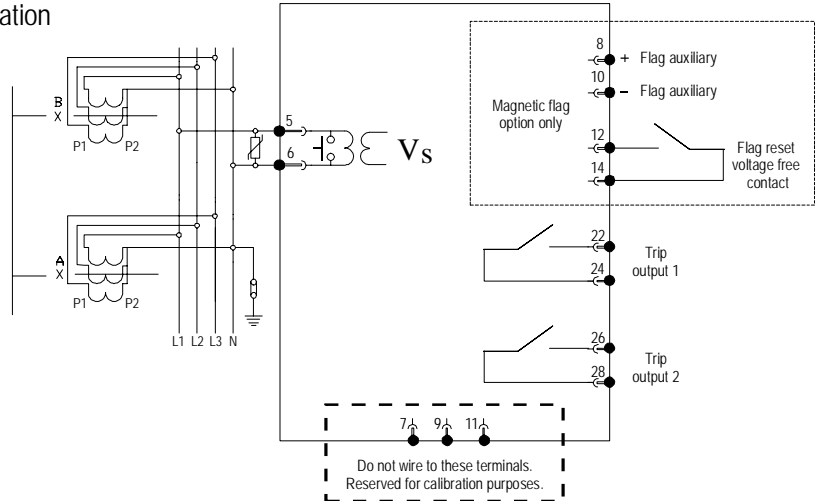

Restricted earth fault application

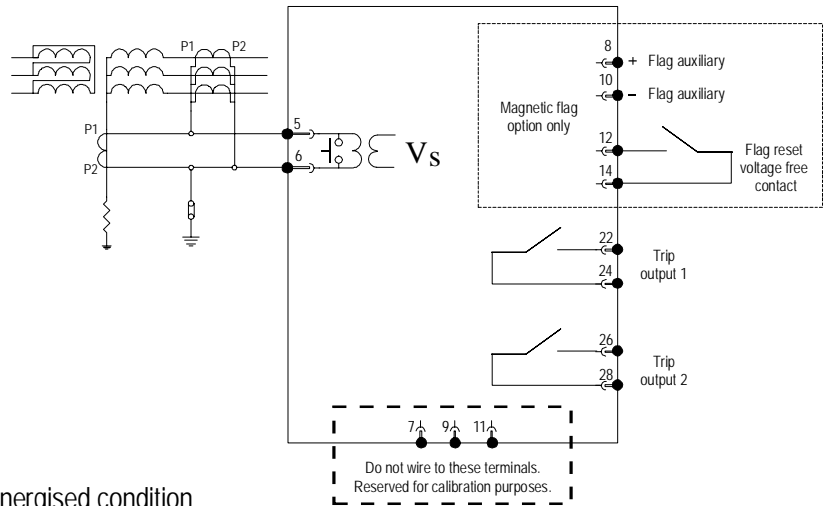

2V73 wiring diagrams - Relay shown in de-energised condition

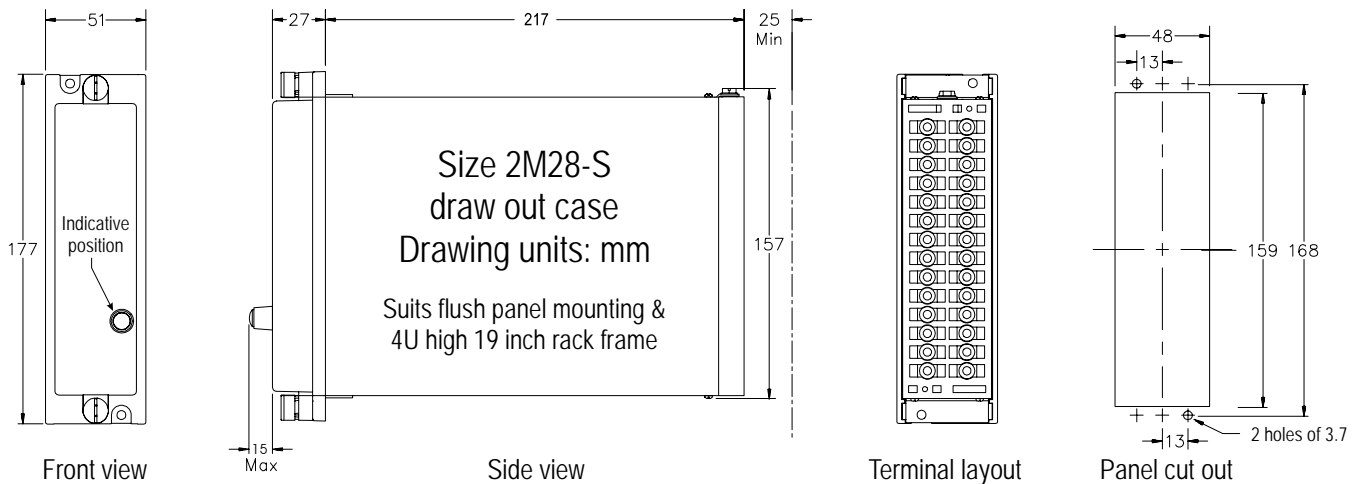

**CASE**

Size 2M28-S draw out case  
 28 M4 screw terminals  
 Flush panel mount or 4U high 1/8 width 19 inch rack mount

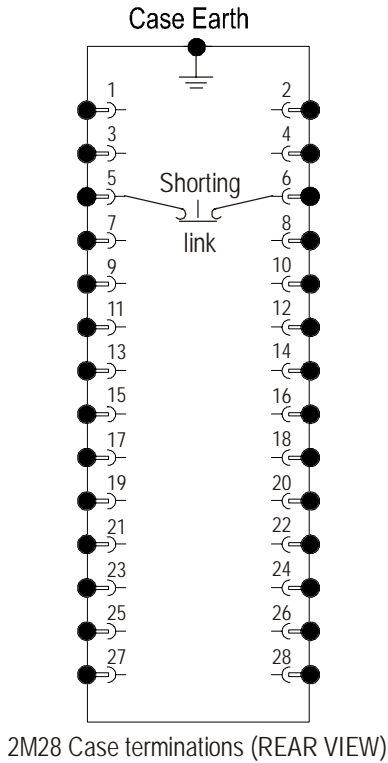

# Ordering Information

Generate the required ordering code as follows: e.g. 2V73 BAA

<b>General Type</b>	<b>Order Code</b>		
	<b>1</b>	<b>2</b>	<b>3</b>
<b>2V73</b>	-		

**1 SETTING RANGE**

- A 25-325V AC in 50V steps
- B 25-115V AC in 15V steps

**2 RATED FREQUENCY**

- A 50 Hz
- B 60 Hz

**3 FLAG TRIP INDICATION**

- A Mechanical flag – no flag auxiliary required
- B Magnetic flag – 24 to 150V DC auxiliary
- C Magnetic flag – 140 to 300 V DC auxiliary

## **Australian Content**

Unless otherwise stated the product(s) quoted are manufactured by RMS at our production facility in Melbourne Australia. Approximately 60% of our sales volume is derived from equipment manufactured in house with a local content close to 90%. Imported components such as semi-conductors are sourced from local suppliers & preference is given for reasonable stock holding to support our build requirements.

## **Quality Assurance**

RMS holds NCSI (NATA Certification Services International), registration number 6869 for the certification of a quality assurance system to AS/NZS ISO9001-2008. Quality plans for all products involve 100% inspection and testing carried out before despatch. Further details on specific test plans, quality policy & procedures may be found in section A4 of the RMS product catalogue.

## **Product Packaging**

Protection relays are supplied in secure individual packing cardboard boxes with moulded styrene inserts suitable for recycling. Each product & packing box is labeled with the product part number, customer name & order details.

## **Design References**

The products & components produced by RMS are based on many years of field experience since Relays Pty Ltd was formed in 1955. A large population of equipment is in service throughout Australia, New Zealand, South Africa & South East Asia attesting to this fact. Specific product & customer reference sites may be provided on application.

## **Product Warranty**

All utility grade protection & auxiliary relay products, unless otherwise stated, are warranted for a period of 24 months from shipment for materials & labour on a return to factory basis. Repair of products damaged through poor application or circumstances outside the product ratings will be carried out at the customer's expense.

## **Standard Conditions of Sale**

Unless otherwise agreed RMS Standard Terms & Conditions (QF 907) shall apply to all sales. These are available on request or from our web site.



## **Relay Monitoring Systems Pty Ltd**

6 Anzed Court, Mulgrave, Victoria 3170, AUSTRALIA

Tel: 61 3 9561 0266 Fax: 61 3 9561 0277 Email: [rms@rmspl.com.au](mailto:rms@rmspl.com.au) Web: [www.rmspl.com.au](http://www.rmspl.com.au)