

## Features

- Modular packaging
- Rack or flush mounting
- Draw out module
- M4 screw terminals
- Operating coils are available for 24, 30, 48, 110, 125, 220 & 250 Volts DC
- Contacts are of fine solid silver designed & manufactured to ensure low resistance & high reliability
- High isolation across open contacts
- High make and carry rating
- Custom labeling available
- High visibility electro-mechanical flag indication
- Rugged modular construction

## Application

Numeric High Impedance Differential Protection Relays with integral Current Transformer (CT) monitoring can be set to detect CT circuit failure i.e. open circuit in the CT Buswires, Switching Contacts or the CT itself. If failure is detected then a 'Pole X CT Failure Alarm' output will be given, this can be used to energise a CT buswire shorting relay.

The type 6RA206-B has a single hand element which enables shorting of all three poles via separate, heavy duty, latching contacts across the buswires of each pole, also provides three latching Common Alarm contacts.

The type 6RA206-D has three separate single-pole hand reset elements which enables shorting of the faulty pole via separate heavy-duty latching contacts across the buswires of the faulty pole leaving the other healthy poles in-service. One additional latching Alarm contact is provided per pole.

The type 6RA207-B has a single element electrically reset element which enables shorting of all three poles via separate, heavy duty, 6 N/O & 3 N/C latching contacts + 1 N/O latching alarm contact.

Where static High Impedance Differential Relays e.g. RMS type 2V73 or 2C73, are used, then a dedicated CT Monitoring Relay type 2V68 with integral CT shorting contacts may be applied to perform both CT Failure detection and automatic three pole shorting of the scheme buswires.

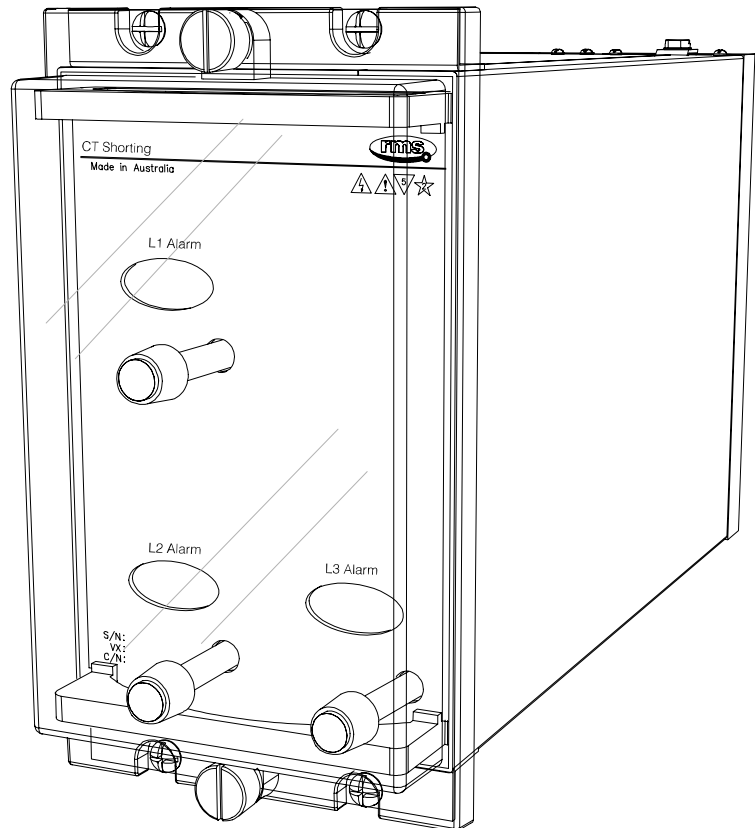

6RA206-Dx depicted in a 4M28 case

## Description

Made in Australia

The 6RA20 CT Shorting relays are a special derivative of the standard 6R MATRIX auxiliary relay. This model range has been designed specifically for CT shorting.

All relay versions are supplied fitted with heavy duty contacts to achieve high voltage isolation across open contacts & high short term carry current.

Contacts are constructed from solid silver, shaped & positioned to ensure very reliable, low resistance operation. Over travel of the contacts during each operation causes a wiping action ensuring a clean "make".

The 6RA207 electrical reset version is fitted with series contacts in the operate & reset coil circuits. This provides thermal protection for the reset coil & a zero burden in the picked up state.

Refer also to the following Fact Sheet for detailed information on product applications & technical specifications:

- ◆ 2V68 CT Monitoring & Shorting Relay



**OPERATE TIME**

Instantaneous operation: <80 ms

**RESET FUNCTION**

6RA206: A manual reset push button is provided on the front panel for each element to reset the flag(s) & contacts.

6RA207: Electrical reset only – No reset button fitted. A series contact is employed in the electrical reset circuit to protect the reset coil.

**OUTPUT RELAY OPERATION INDICATOR**

Each relay element is supplied with a flag (target) indicator. The indicator consists of a high visibility solid dayglow orange mechanical flag.



6RA206: One hand reset flag per element  
Target visible when the contacts are picked up

6RA207: One self reset flag per element  
Target visible when the contacts are reset

**ALARM CONTACTS**

6RA206: 3 N/O latching hand reset contacts  
6RA207: 1 N/O electrically reset contact

**BUSWIRE SHORTING CONTACTS**

6RA206: 3 N/O latching hand reset contacts  
6RA207: 3 N/C electrically reset contacts  
6 N/O electrically reset contacts

**BURDENS**

6RA206: Operating burden: <3 W at nominal voltage  
Reset burden: <25 W at nominal voltage

6RA207: Operating burden: <3 W at nominal voltage  
A series contact is employed in the operate coil circuit to ensure zero burden in the picked up state.  
Operated burden: Zero  
Reset burden: <25 W at nominal voltage

**OPERATING VOLTAGE**

75% to 125% of nominal DC voltage.

**THERMAL RATING**

All operate circuits are designed to withstand continuous application of 125% of nominal voltage.

**CASE**

Single element version for three pole common CT shorting

Size 2-S draw out  
28 M4 screw terminals  
Flush panel mount or 4U high 1/8 width 19 inch rack mount  
IP51 rating  
The 6RA207 version has automatic CT shorting switches fitted to the outer case across the 3 N/C contacts.

Three element version for phase segregated CT shorting

Size 4-S draw out  
28 M4 screw terminals  
Flush panel mount or 4U high 1/4 width 19 inch rack mount  
IP51 rating

**ACCESSORIES SUPPLIED WITH EACH RELAY**

1 x M4 self threading mounting screw kit P/N 290-406-151  
1 x M4 terminal screw kit (28 per kit) P/N 290-407-153

**Technical Data**

**6R RELAY CONTACT RATINGS**

**Make & Carry Continuously**

3,000 VA AC resistive with maximums of 660 V & 12 A  
3,000 W DC resistive with maximums of 660 V & 12 A

**Make & Carry for 3 Seconds**

7,500 VA AC resistive with maximums of 660 V & 30 A  
7,500 W DC resistive with maximums of 660 V & 30 A

**Carry for 0.5s**

150 A rms for 0.5 s

**AC Break Capacity**

3,000 VA AC resistive with maximums of 660 V & 12 A

**DC Break Capacity (amps)**

Voltage		24 V	48 V	125 V	250 V
Resistive rating		12	1.5	0.5	0.25
L/R=40ms	Maximum break	12	1	0.25	0.15

**Isolation Across Open Buswire Shorting Contacts**

3 kV rms

**Isolation Across Open Alarm Contacts**

1 kV rms

**INSULATION WITHSTAND**

IEC60255-5

2 kV rms for one minute & 1.2/50 5 kV impulse between:

- ◆ all input terminals & frame
- ◆ all output terminals & frame
- ◆ all input & output terminals
- ◆ each input group
- ◆ each output group

**AMBIENT OPERATING TEMPERATURE RANGE**

-10 to 55 degrees C



# 3 Pole Common 6RA206 Hand Reset Version

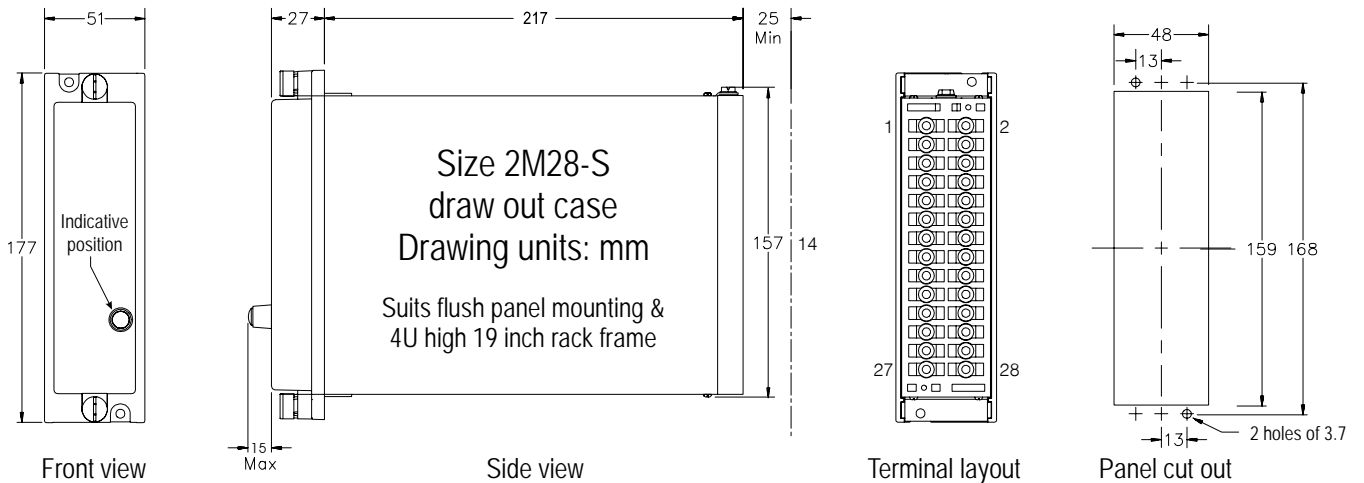
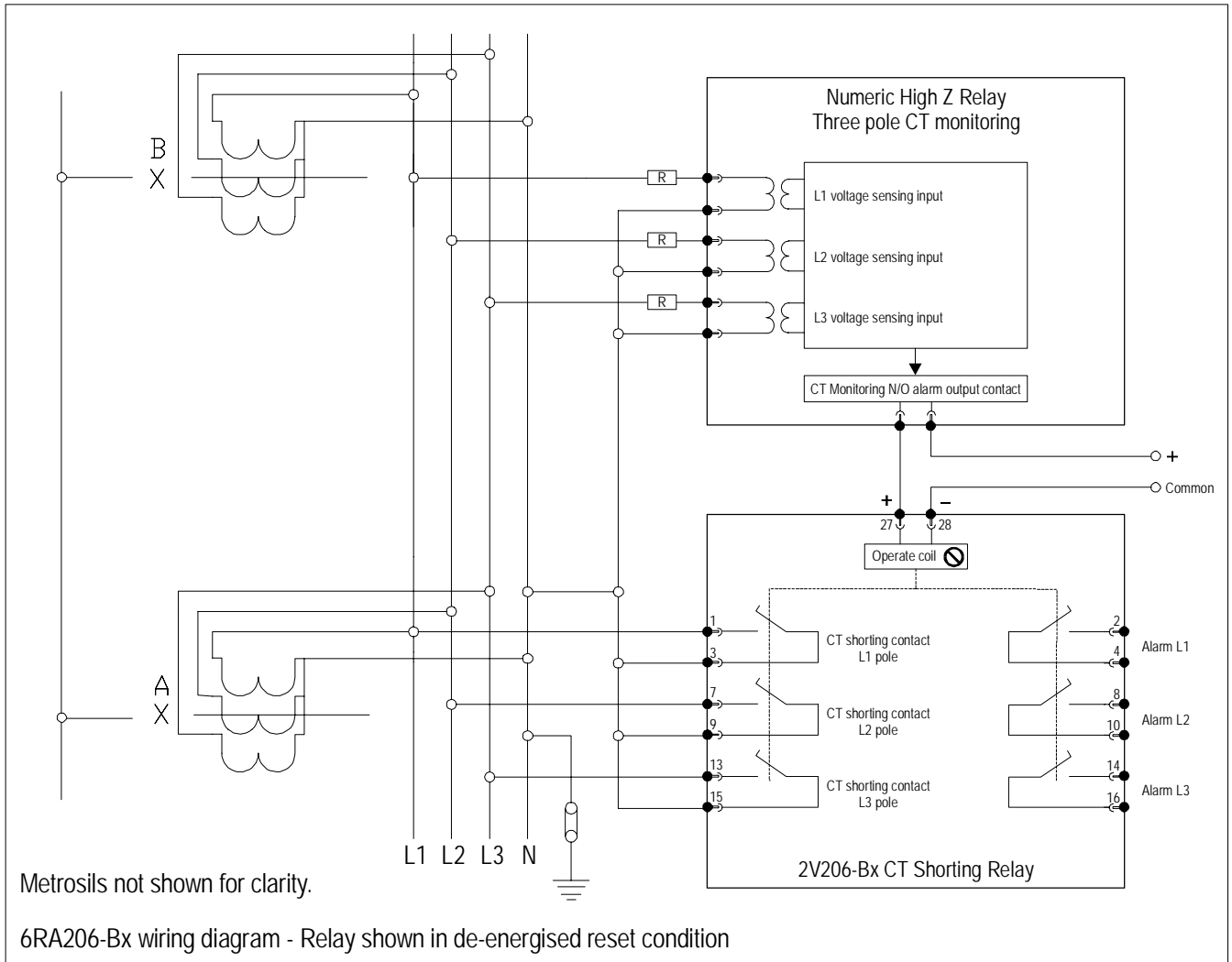

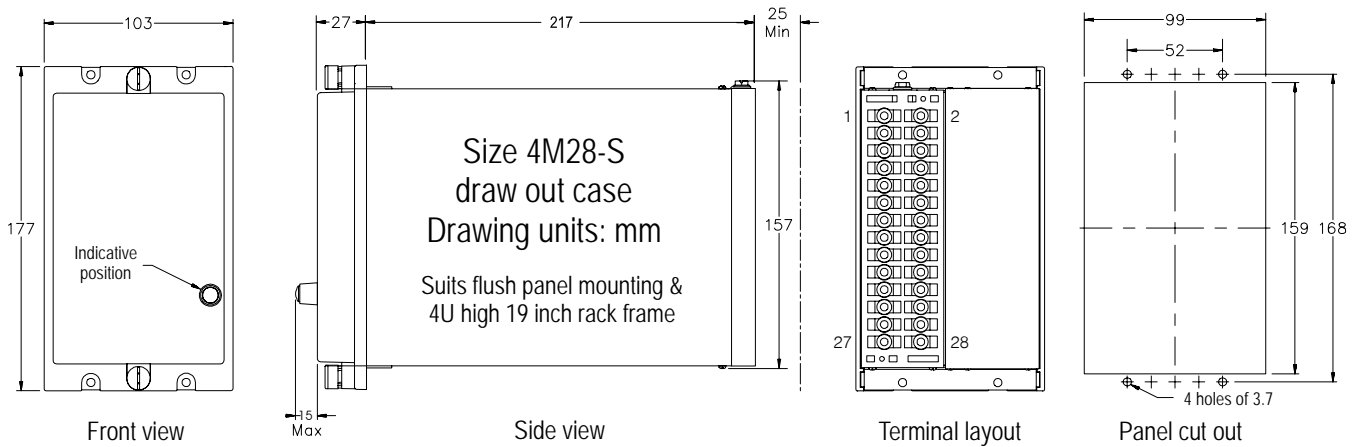
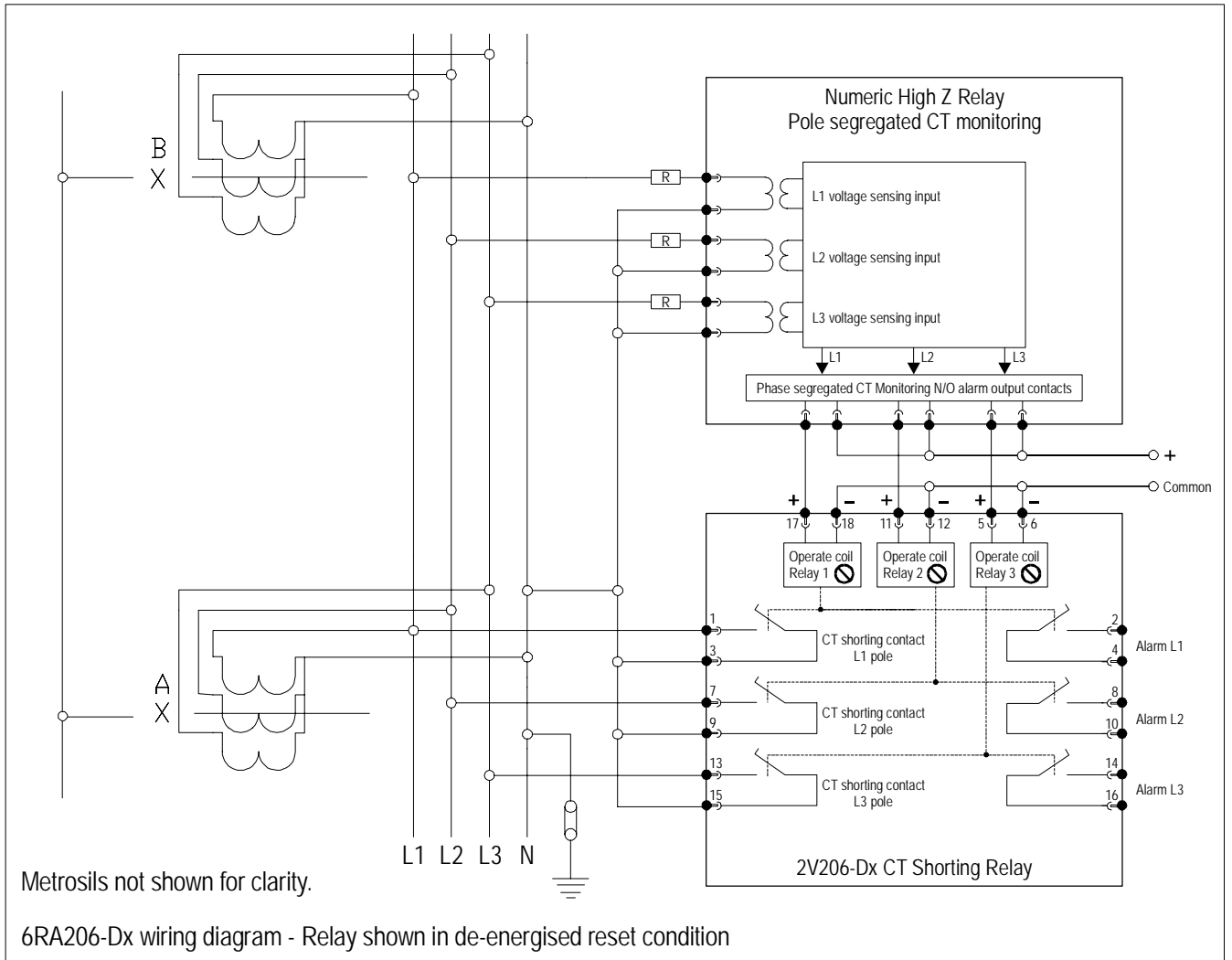

# 3 Pole Common 6RA207 Electrically Reset Version

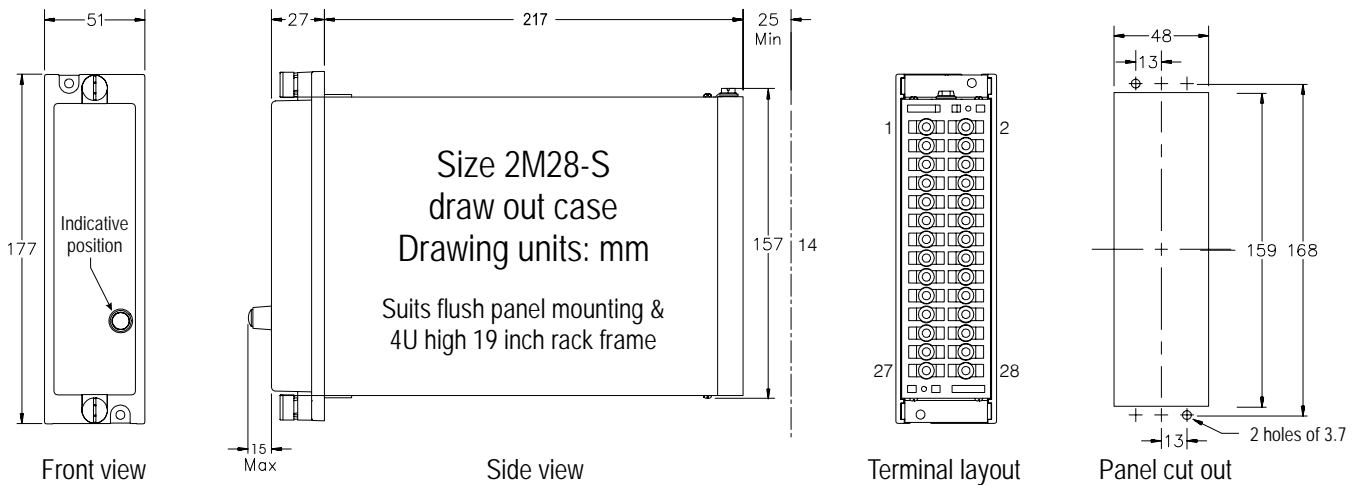
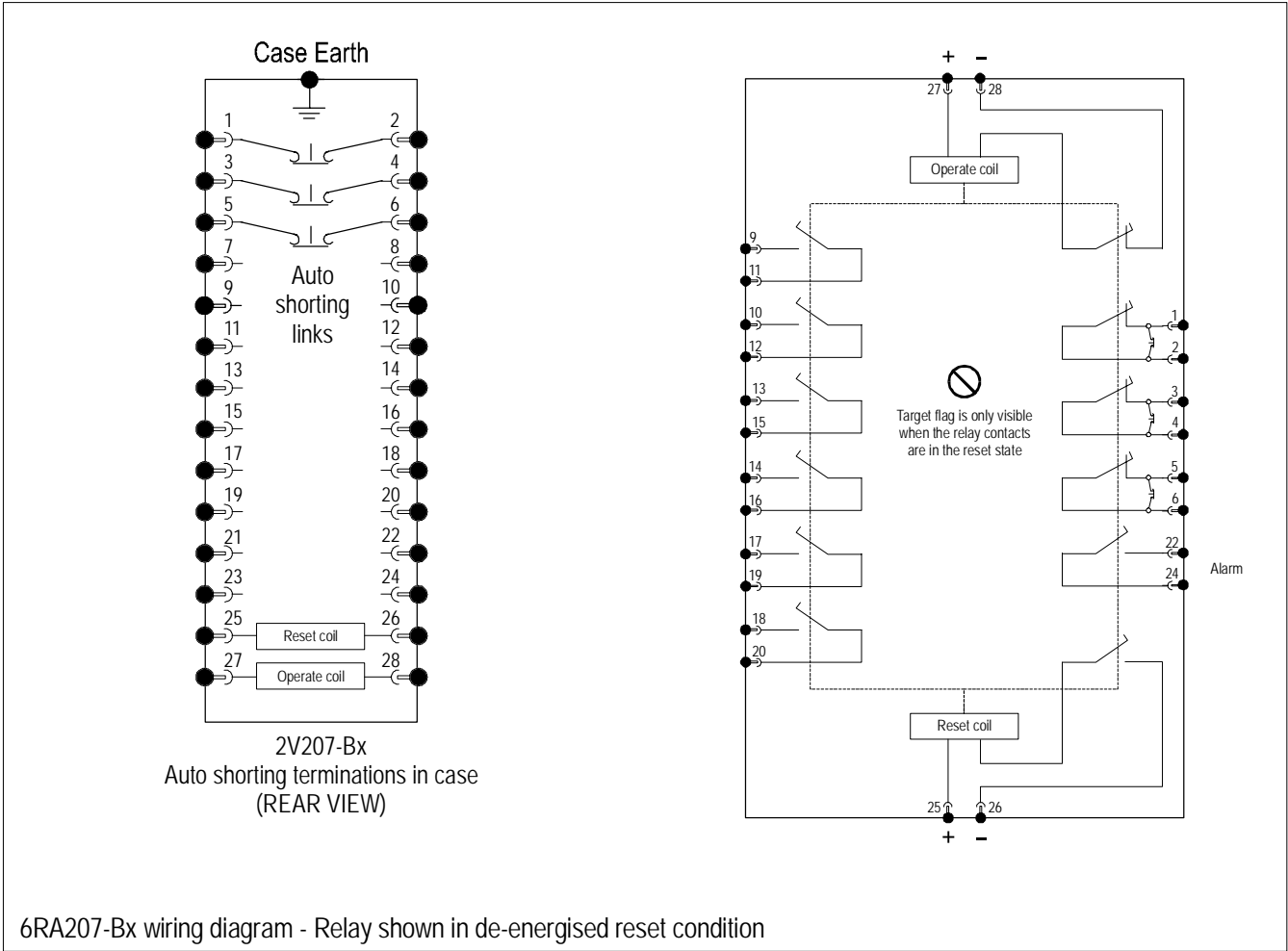

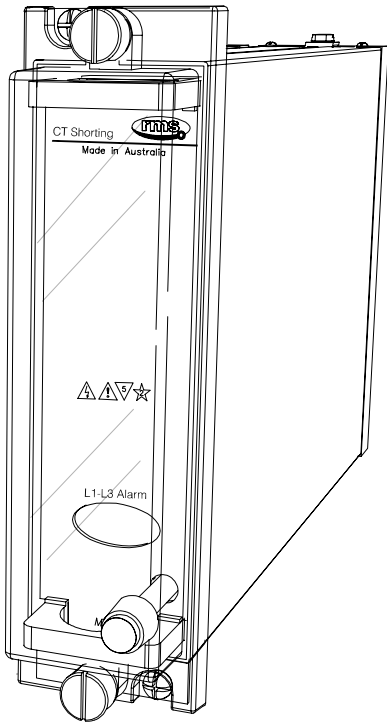

6RA206-Bx depicted in a 2M28 case

# Ordering Information

Generate the required order code follows: e.g. 6RA206-BE

General Type	Order Code		
	1	2	3
6RA20		-	

## 1 CONTACT OPERATION

- 6 Hand reset
- 7 Electrically reset

## 2 FUNCTION

- B 3 pole common CT shunting
- D Phase segregated CT shunting - Type 6RA206 only

## 3 NOMINAL OPERATE VOLTAGE

- A 24V DC
- B 30V DC
- C 48V DC
- D 110V DC
- E 125V DC
- F 220V DC
- G 250V DC

### ELEMENT 1 L1-L3 / L1 (Top left)

Custom Text (Optional)

### ELEMENT 2 L2 (Bottom left) Size 4M28 case

Custom Text (Optional)

### ELEMENT 3 L3 (Bottom right) Size 4M28 case

Custom Text (Optional)

## **Australian Content**

Unless otherwise stated the product(s) quoted are manufactured by RMS at our production facility in Melbourne Australia. Approximately 60% of our sales volume is derived from equipment manufactured in house with a local content close to 90%. Imported components such as semi-conductors are sourced from local suppliers & preference is given for reasonable stock holding to support our build requirements.

## **Quality Assurance**

RMS holds NCSI (NATA Certification Services International), registration number 6869 for the certification of a quality assurance system to AS/NZS ISO9001-2000. Quality plans for all products involve 100% inspection and testing carried out before despatch. Further details on specific test plans, quality policy & procedures may be found in section A4 of the RMS product catalogue.

## **Product Packaging**

Protection relays are supplied in secure individual packing cardboard boxes with moulded styrene inserts suitable for recycling. Each product & packing box is labeled with the product part number, customer name & order details.

## **Design References**

The products & components produced by RMS are based on many years of field experience since Relays Pty Ltd was formed in 1955. A large population of equipment is in service throughout Australia, New Zealand, South Africa & South East Asia attesting to this fact. Specific product & customer reference sites may be provided on application.

## **Product Warranty**

All utility grade protection & auxiliary relay products, unless otherwise stated, are warranted for a period of 24 months from shipment for materials & labour on a return to factory basis. Repair of products damaged through poor application or circumstances outside the product ratings will be carried out at the customer's expense.

## **Standard Conditions of Sale**

Unless otherwise agreed RMS Standard Terms & Conditions (QF 907) shall apply to all sales. These are available on request or from our web site.



## **Relay Monitoring Systems Pty Ltd**

6 Anzed Court, Mulgrave, Victoria 3170, AUSTRALIA

Tel: 61 3 9561 0266 Fax: 61 3 9561 0277 Email: [rms@rmspl.com.au](mailto:rms@rmspl.com.au) Web: [www.rmspl.com.au](http://www.rmspl.com.au)