

Features

- Low burden
- Contacts picked up for healthy trip coil condition
- Slug time delay
- Hand reset flag indicator
- 2 C/O contacts standard
- Draw out case
- Equivalent function to MVAX11
- 1TM13 specification

Application

The operating element for the 6R MATRIX supervision relay functional elements are designated 6RX & are based on our 6R Series relays.

The 6RX11 relay is designed to supervise trip relay circuits utilizing high burden trip relays such as the 6RJ & 2HSM series available from RMS.

The operating element of the 6RX11 comprises a single 6R heavy-duty attracted armature control relay with a single operating coil & delay slug. It has two dropping resistors R1 & R2 of equal ohmic value, connected in series with the coil.

If the circuit being supervised becomes open circuited or if the supply fails, the relay will become reenergized and an alarm or visual indication will be given.

Under healthy conditions the relay coil is energized via the dropping resistor R1 as shown below (Tripping relay circuit). If the circuit being supervised becomes open circuit or if the supply fails, the relay will become de-energized & an alarm is given (2 C/O contacts & flag indication).

To prevent the alarm being given when the circuit being supervised is operated the relay coil is maintained via the dropping resistor R2. For this purpose, an additional normally open contact is required from the latching tripping relay as depicted at right. A short time delay (>100ms), is incorporated to hold up the alarm trip relay during a normal trip relay operation.

Contacts are constructed from silver, shaped & positioned to ensure reliable, low resistance operation. Over travel of the contacts during each operation causes a wiping action ensuring a clean "make".

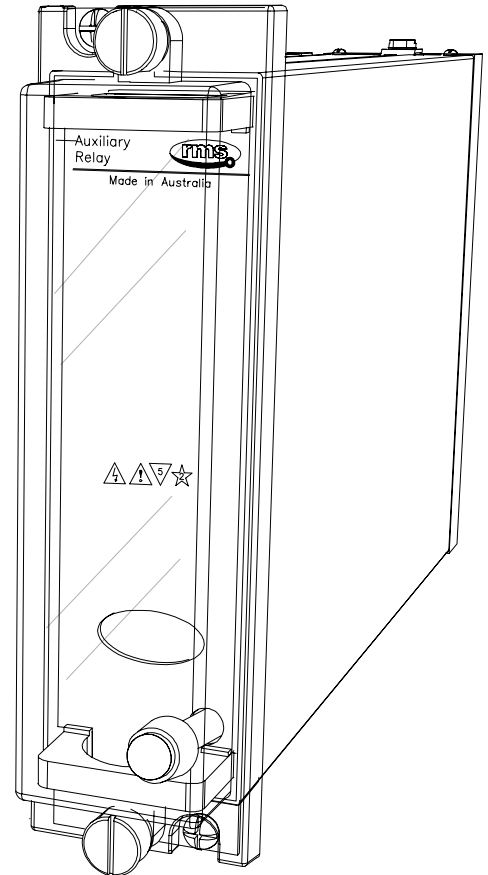

2M28 draw out case

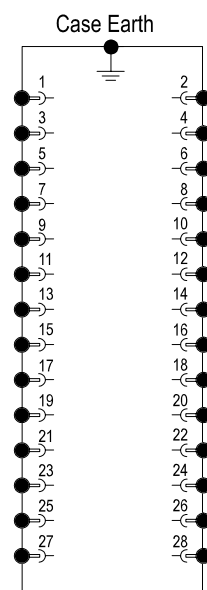

2M28 Case terminations (REAR VIEW)

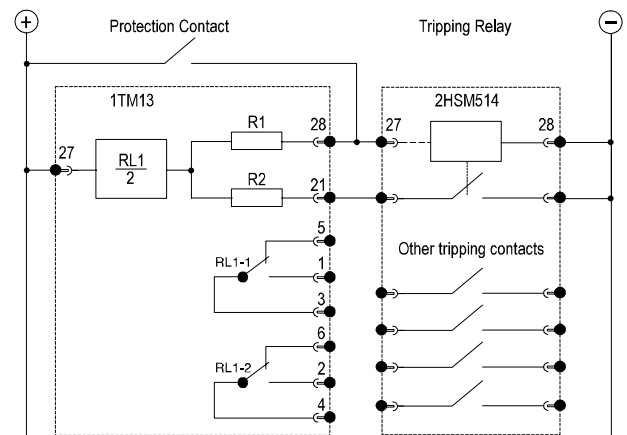

CIRCUIT RESISTANCE & BURDEN

The 6RX11 circuit design is optimized to minimize the supervision current in the tripping relay circuit to avoid the possibility of nuisance tripping. The total series resistance provided by the combination of RL1/R1 & RL1/R2 is tabulated below. Resistance of the CB coil must be much less than this figure to ensure adequate supervision current flows through the 6RX11 element under normal conditions.

Nominal supply	~Resistance (ohms)	Burden * (Watts)
32V DC	2,200	<0.6
48V DC	3,100	<0.9
110V DC	8,000	<1.7
125V DC	8,000	<2.2

TRIP SUPPLY BURDEN

* Actual operating burden is dependent on the tripping relay resistance

THERMAL RATING

All operate & reset circuits are designed to withstand continuous application of 120% of nominal voltage

FLAG OPERATION

Each relay element is supplied with a flag (target) indicator. The indicator consists of a high visibility solid dayglow orange mechanical flag.

Operation: Drops on coil de-energisation.
Reset: Hand reset.

OPERATING VOLTAGE RANGE

Guaranteed operation between 70% & 120% of nominal rated operating voltage.

NOMINAL OPERATING VOLTAGES

24, 32, 48, 110, 125, 220, 240 & 250V DC available.

DROP OUT VOLTAGE

Drop out voltage: >10% of nominal rated operate voltage.

CONTACTS

2 C/O standard
Up to 4 M or B contacts - user to specify combination of make & break contacts

INSULATION WITHSTAND in accordance with IEC 255-5:

2KV RMS & 1.2/50 5KV impulse between:

- ◆ all terminals & frame
- ◆ each contact group
- ◆ all contacts & coil

CASE SIZE

2M28-S draw out case

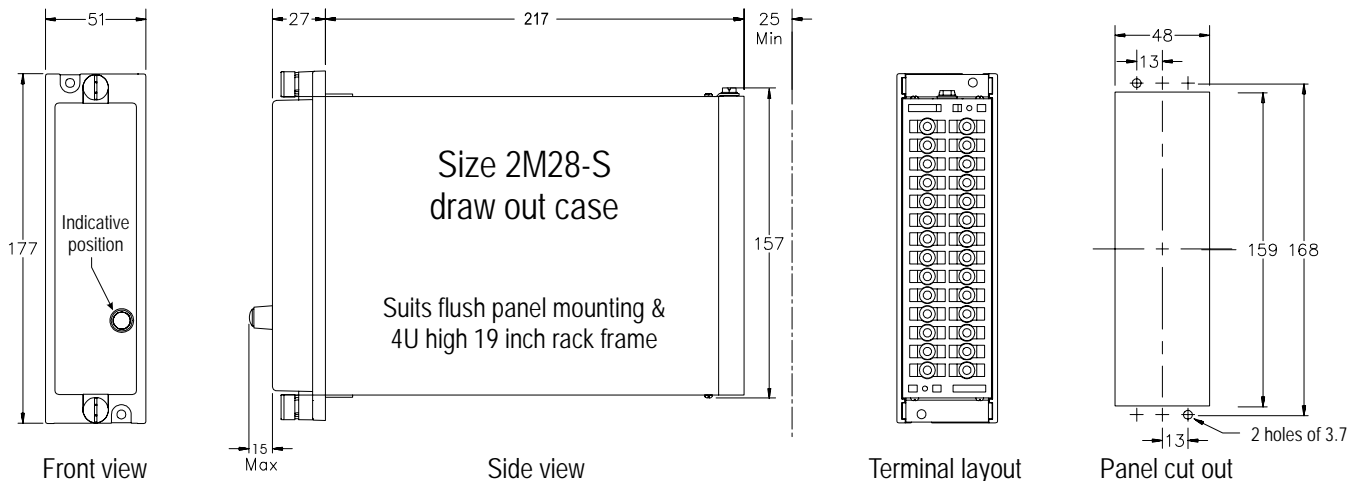

Ordering Codes

Generate the required ordering code as follows:
e.g. 6RX11-D-2C

6RX11

1

1 NOMINAL OPERATE VOLTAGE

A 24V DC	E 125V D
B 32V DC	G 220V DC
C 48V DC	H 240V DC
D 110V DC	F 250V DC

5 CONTACT ARRANGEMENT – 2 C/O standard

Specify the number of "MAKES" followed by M; i.e. 2M
Specify the number of "BREAKS" followed by B; i.e. 2B
Specify the number of "CHANGEOVER" followed by C; i.e. 2C

ELEMENT TEXT (Optional)

Element part number is used as the default

--	--	--	--	--	--	--	--	--	--	--

6R RELAY CONTACT RATINGS

Make & Carry Continuously

3,000 VA AC resistive with maximums of 660V & 12A
3,000 W DC resistive with maximums of 660V & 12A

Make & Carry for 3 Seconds

7,500 VA AC resistive with maximums of 660V & 30A
7,500 W DC resistive with maximums of 660V & 30A

AC Break Capacity

3,000 VA AC resistive with maximums of 660V & 12A

DC Break Capacity (Amps)

Voltage	24V	48V	125V	250V
Resistive rating	12	2	0.5	0.25
L/R=40ms Maximum break	12	1	0.25	0.15

Australian Content

Unless otherwise stated the product(s) quoted are manufactured by RMS at our production facility in Melbourne Australia. Approximately 60% of our sales volume is derived from equipment manufactured in house with a local content close to 90%. Imported components such as semi-conductors are sourced from local suppliers & preference is given for reasonable stock holding to support our build requirements.

Quality Assurance

RMS holds NCSI (NATA Certification Services International), registration number 6869 for the certification of a quality assurance system to AS/NZS ISO9001-2008. Quality plans for all products involve 100% inspection and testing carried out before despatch. Further details on specific test plans, quality policy & procedures may be found in section A4 of the RMS product catalogue.

Product Packaging

Protection relays are supplied in secure individual packing cardboard boxes with moulded styrene inserts suitable for recycling. Each product & packing box is labeled with the product part number, customer name & order details.

Design References

The products & components produced by RMS are based on many years of field experience since Relays Pty Ltd was formed in 1955. A large population of equipment is in service throughout Australia, New Zealand, South Africa & South East Asia attesting to this fact. Specific product & customer reference sites may be provided on application.

Product Warranty

All utility grade protection & auxiliary relay products, unless otherwise stated, are warranted for a period of 24 months from shipment for materials & labour on a return to factory basis. Repair of products damaged through poor application or circumstances outside the product ratings will be carried out at the customer's expense.

Standard Conditions of Sale

Unless otherwise agreed RMS Standard Terms & Conditions (QF 907) shall apply to all sales. These are available on request or from our web site.



Relay Monitoring Systems Pty Ltd

6 Anzed Court, Mulgrave, Victoria 3170, AUSTRALIA

Tel: +61 3 8544 1200 Fax: +61 3 8544 1201 Email: rms@rmspl.com.au Web: www.rmspl.com.au