

## Features

- Low burden
- Monitors CB in both open & closed condition
- Contacts picked up for healthy supply condition contacts
- Slug time delay
- Hand reset flag indicator
- 2 C/O contacts (Standard)
- Draw out case
- Equivalent function to MVAX21
- 1TM10 specification

## Application

The operating element for the 6R MATRIX supervision relay functional elements are designated 6RX & are based on our 6R Series relays.

The operating element of the 6RX21 comprises a single 6R heavy duty attracted armature control relay with two operating coils wound on a single core.

Supervision is active with the circuit breaker in the open or closed position via the 52a & b auxiliary contacts.

Under healthy conditions, with the CB in the closed position, coil winding 1 is energized & if the trip coil becomes open circuited or the supply fails, the relay will drop out initiating the local visual indicator & output contacts. Similarly, when the CB is in the open position, both coil windings are energized enabling the relay to detect failure of the trip circuit coil or supply in the same manner as if closed. Once operated the electro-mechanical alarm flag must be hand reset.

The relay element is fitted with a slug to provide a delay on de-energisation preventing a false alarm due to voltage dips in the supply rail, or the normal delays in the tripping operation, when the first coil winding is momentarily short circuited by the protection trip contact. If the protection trip contact should fail to reset, due to a failure of the circuit breaker tripping mechanism for example, the relay drops out initiating the local visual alarm indicator & output contacts.

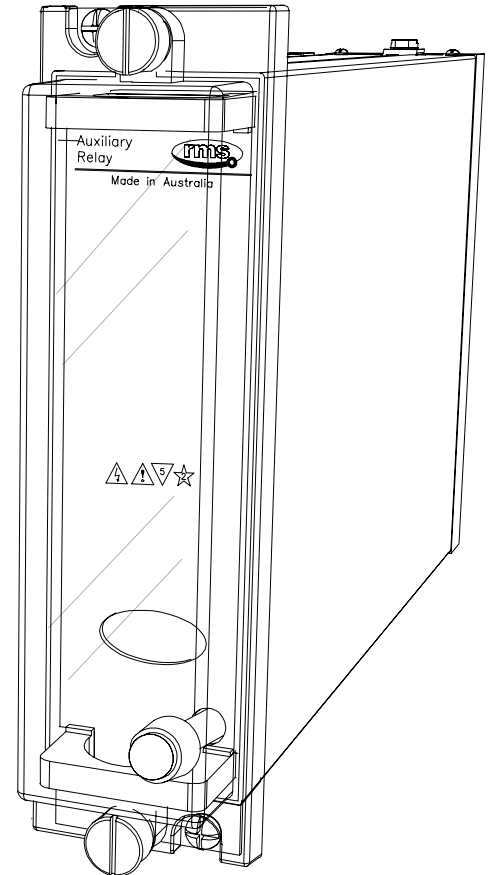

2M28 draw out case

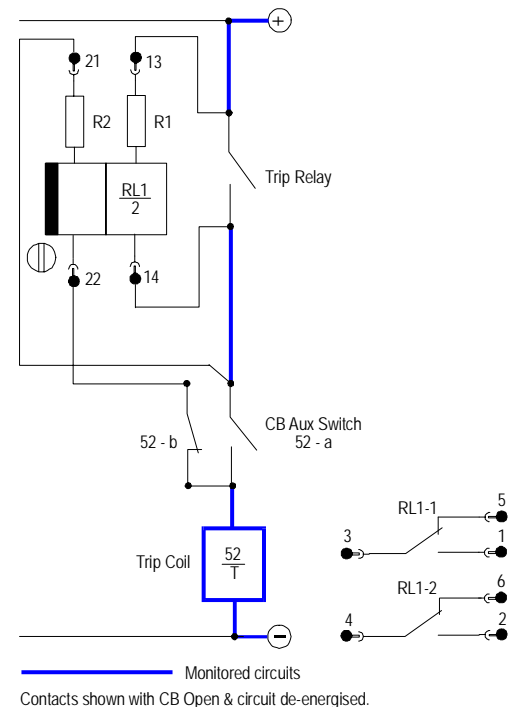
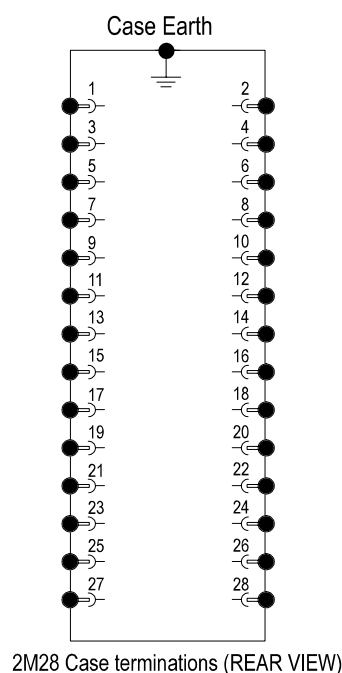

### CIRCUIT RESISTANCE & BURDEN

The 1TM10 circuit design is optimized to minimize the supervision current in the CB trip coil to avoid the possibility of nuisance tripping. The total series resistance provided by R1 & RL1 - winding 1 is tabulated below. Resistance of the CB coil must be much less than these figures to ensure adequate supervision current flows through the 1TM10 element under normal conditions.

Nominal supply	~Resistance (ohms)	Current (mA)	Burden * (Watts)
32V DC	2,200	15	<0.5
48V DC	3,100	15	<0.8
110V DC	7,400	15	<1.7
125V DC	7,400	17	<2.2
220V DC	25,000	9	<2.0
240V DC	25,000	10	<2.4
250V DC	25,000	10	<2.5

### TRIP SUPPLY BURDEN

\* Actual operating burden is dependent on the CB coil resistance.

### THERMAL RATING

All operate & reset circuits are designed to withstand continuous application of 120% of nominal voltage

### FLAG OPERATION

Each relay element is supplied with a flag (target) indicator. The indicator consists of a high visibility solid dayglow orange mechanical flag.

Operation: Drops on coil de-energisation.  
Reset: Hand reset.

### OPERATING VOLTAGE RANGE

Guaranteed operation between 80% & 120% of nominal rated operating voltage.

### DROP OUT VOLTAGE

Drop out between 25 & 40% of nominal rated operate voltage.

### RESET TIME

Not less than 300ms when supply is switched from 100% of nominal rated operating voltage to off.

### NOMINAL OPERATING VOLTAGES

24, 32, 48, 110, 125, 220, 240 & 250V DC available.

### CONTACTS

2 C/O standard  
Up to 4 M or B contacts - user to specify combination of make & break contacts

## Ordering Codes

Generate the required ordering code as follows:  
e.g. 6RX21-D

6RX21 - 

1
---

### 1 NOMINAL OPERATE VOLTAGE

A	24V DC	E	125V D
B	32V DC	G	220V DC
C	48V DC	H	240V DC
D	110V DC	F	250V DC

### 6R RELAY CONTACT RATINGS

#### Make & Carry Continuously

3,000 VA AC resistive with maximums of 660V & 12A  
3,000 W DC resistive with maximums of 660V & 12A

#### Make & Carry for 3 Seconds

7,500 VA AC resistive with maximums of 660V & 30A  
7,500 W DC resistive with maximums of 660V & 30A

#### AC Break Capacity

3,000 VA AC resistive with maximums of 660V & 12A

#### DC Break Capacity (Amps)

Voltage	24V	48V	125V	250V	
Resistive rating	12	2	0.5	0.25	
L/R=40ms	Maximum break	12	1	0.25	0.15

### INSULATION WITHSTAND in accordance with IEC 255-5:

2KV RMS & 1.2/50 5KV impulse between:

- ◆ all terminals & frame
- ◆ each contact group
- ◆ all contacts & coil

### CASE SIZE

2M28-S draw out case

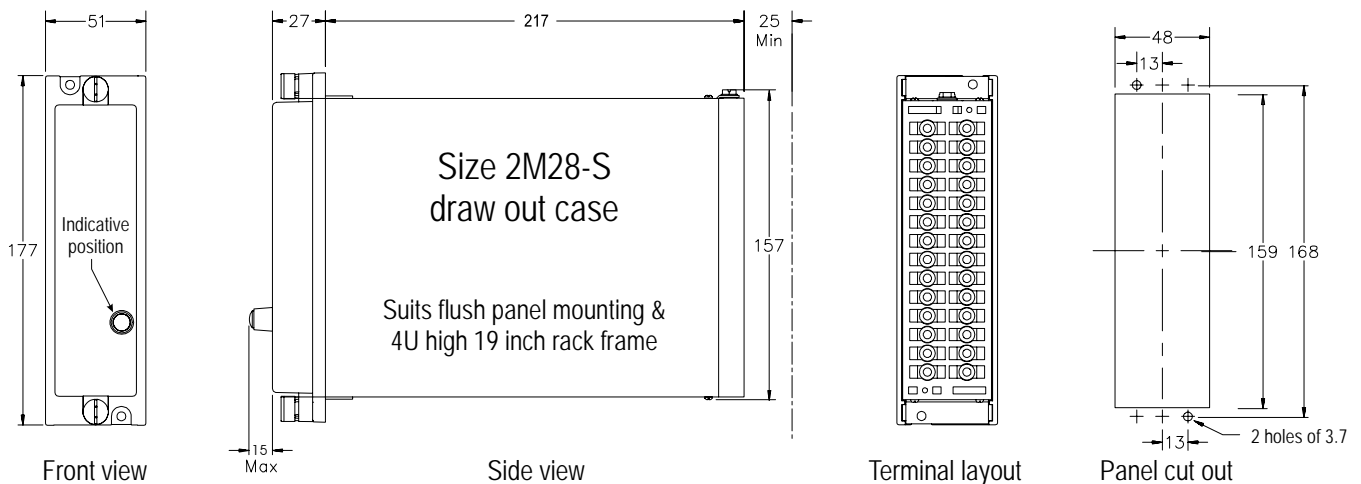

## **Australian Content**

Unless otherwise stated the product(s) quoted are manufactured by RMS at our production facility in Melbourne Australia. Approximately 60% of our sales volume is derived from equipment manufactured in house with a local content close to 90%. Imported components such as semi-conductors are sourced from local suppliers & preference is given for reasonable stock holding to support our build requirements.

## **Quality Assurance**

RMS holds NCSI (NATA Certification Services International), registration number 6869 for the certification of a quality assurance system to AS/NZS ISO9001-2008. Quality plans for all products involve 100% inspection and testing carried out before despatch. Further details on specific test plans, quality policy & procedures may be found in section A4 of the RMS product catalogue.

## **Product Packaging**

Protection relays are supplied in secure individual packing cardboard boxes with moulded styrene inserts suitable for recycling. Each product & packing box is labeled with the product part number, customer name & order details.

## **Design References**

The products & components produced by RMS are based on many years of field experience since Relays Pty Ltd was formed in 1955. A large population of equipment is in service throughout Australia, New Zealand, South Africa & South East Asia attesting to this fact. Specific product & customer reference sites may be provided on application.

## **Product Warranty**

All utility grade protection & auxiliary relay products, unless otherwise stated, are warranted for a period of 24 months from shipment for materials & labour on a return to factory basis. Repair of products damaged through poor application or circumstances outside the product ratings will be carried out at the customer's expense.

## **Standard Conditions of Sale**

Unless otherwise agreed RMS Standard Terms & Conditions (QF 907) shall apply to all sales. These are available on request or from our web site.



## **Relay Monitoring Systems Pty Ltd**

6 Anzed Court, Mulgrave, Victoria 3170, AUSTRALIA

Tel: +61 3 8544 1200 Fax: +61 3 8544 1201 Email: [rms@rmspl.com.au](mailto:rms@rmspl.com.au) Web: [www.rmspl.com.au](http://www.rmspl.com.au)