

Voltage Dropping Resistor Modules

Features

- Good heat sinking capability (when mounted on metal panel)
- High reliability
- +/- 5% Tolerance
- Small footprint
- Compact assembly
- Ease of connection
- High temperature connector
- 2 KV RMS insulation
- Rugged construction
- DIN rail mountable
- Wide range of values available
- Made in Australia

Application

The FRW20 range of resistor modules can be used where external dropping resistors are required. When the assembly is mounted on the metal cabinet or cubicle the temperature rise of the resistors is greatly reduced when compared to the heating effect of normal stud mounted resistors used by some relay manufacturers.

The FRW resistor modules are particularly suitable for use with the following RMS protection relay types:

- ◆ 2C135 Sensitive Earth Fault
- ◆ 2C80 Current Check
- ◆ 1TM10 Trip Circuit Supervision
- ◆ 1TM12 Trip Circuit Supervision

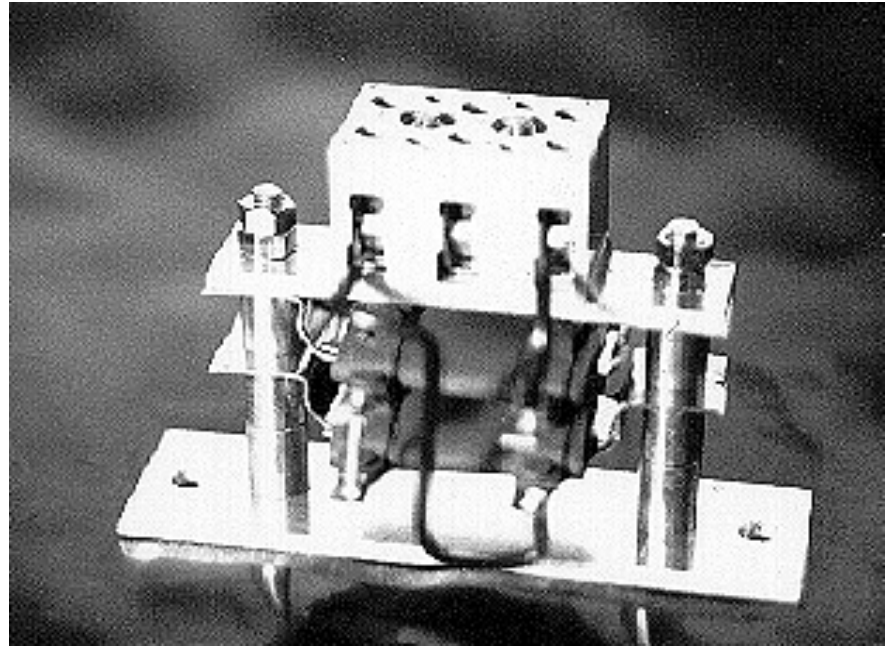

Construction

Made in Australia

The resistor assemblies are constructed using locally made resistors ensuring availability of spare parts should this become necessary. The resistors used have a Pyrosil coating which protects the winding wire and terminations from contaminants which are usually associated with the environment where these modules are installed. The continued reliability of these units is dependant on the heat generated by the resistors being able to be dissipated into the mounting metalwork & surrounding air. The module and ambient temperatures must therefore be taken into account using the de-rating factors shown in the tables below.

The modules are available in assemblies up to 5 resistors high but multiple stacks must be de-rated to maintain their specified dissipation. The de-rating factor (X) for multiple stacks is shown in table 2 below.

Ambient temperature must also be taken into consideration when a multiple stack module is to be used, these de-rating figures (Y) are shown in table 3. To determine the combined effect for de-rating of the resistors multiply by X & Y.

Table 1
Temperature rise of modules in free air

| | | | | |
|----------------|----|-----|-----|-----|
| Watt | 5 | 10 | 15 | 20 |
| ^o C | 80 | 150 | 200 | 250 |

Table 2
De-rating factors (X) for stacked resistors

| No of resistors | Vertical mounted (X) | Horizontal mounted (X) |
|-----------------|----------------------|------------------------|
| 1 | 1.0 | 1.0 |
| 2 | 0.82 | 0.75 |
| 3 | 0.70 | 0.55 |
| 4 | 0.65 | 0.40 |
| 5 | 0.60 | 0.32 |

Table 3
De-rating factors (Y) for ambient temperature.

| | | | | |
|------------------------|-----|------|------|------|
| Ambient ^o C | 40 | 60 | 80 | 100 |
| De-rating factor Y | 1.0 | 0.87 | 0.75 | 0.62 |

Generate the required ordering code as follows: e.g. 4F20 [3][M][P][][-]

4F20

1 RESISTOR COMBINATION NUMBER

1-16 Refer drawings at left

2 RESISTOR 1 VALUE

A-V Refer table below

3 RESISTOR 2 VALUE

A-V Refer table below

4 RESISTOR 3 VALUE

A-V Refer table below

5 RESISTOR 4 VALUE

A-V Refer table below

Resistor combination are specified with the first resistor closest to the terminal block (R1)

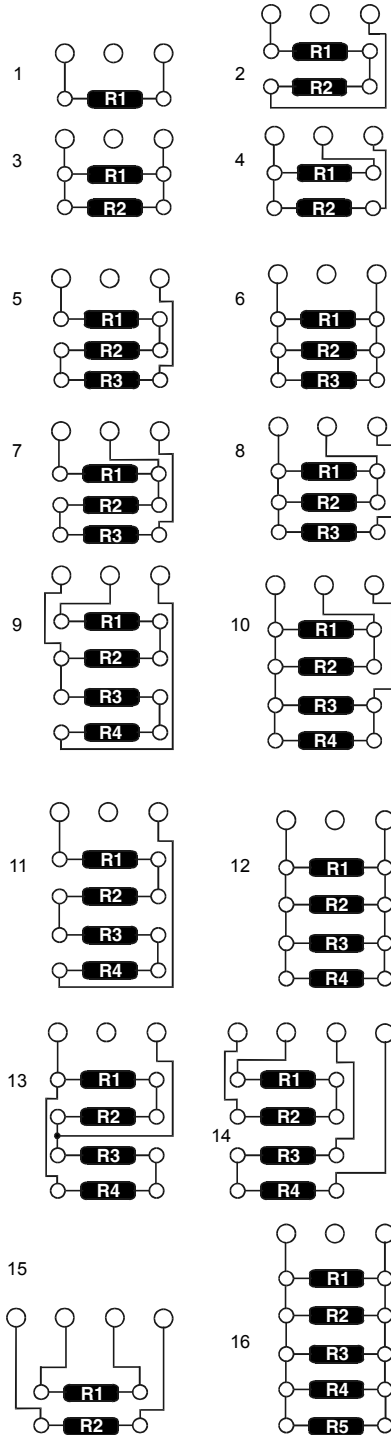

Standard connection combinations are shown. The resistor values can be selected from the standard resistor list and can be made to any combination as shown.

| Resistor Value Code | Value in Ohms |
|---------------------|---------------|
| - | Not fitted |
| A | 10 |
| B | 47 |
| C | 100 |
| D | 150 |
| E | 220 |
| F | 300 |
| G | 330 |
| H | 470 |
| I | 680 |
| J | 750 |
| K | 1,000 |
| L | 1,100 |
| M | 1,200 |
| N | 1,500 |
| O | 1,800 |
| P | 2,200 |
| Q | 2,700 |
| R | 3,300 |
| S | 3,900 |
| T | 4,700 |
| U | 5,100 |
| V | 6,800 |

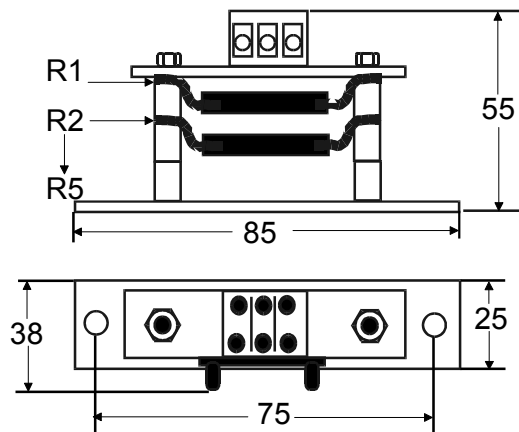

*Add 12 mm for each additional resistor when stacking

Australian Content

Unless otherwise stated the product(s) quoted are manufactured by RMS at our production facility in Melbourne Australia. Approximately 90% of our sales volume is derived from equipment manufactured in house with a local content close to 90%. Imported components such as semi-conductors are sourced from local suppliers & preference is given for reasonable stock holding to support our build requirements.

Quality Assurance

RMS holds NCSI (NATA Certification Services International), registration number 6869 for the certification of a quality assurance system to AS/NZS ISO9001-1994. Quality plans for all products involve 100% inspection and testing carried out before despatch. Further details on specific test plans, quality policy & procedures may be found in section A4 of the RMS product catalogue.

Product Packaging

Protection relays are supplied in secure individual packing cardboard boxes with moulded styrene inserts suitable for recycling. Each product & packing box is labeled with the product part number, customer name & order details.

Design References

The products & components produced by RMS are based on many years of field experience since Relays Pty Ltd was formed in 1955. A large population of equipment is in service throughout Australia, New Zealand, South Africa & South East Asia attesting to this fact. Specific product & customer reference sites may be provided on application.

Product Warranty

All utility grade protection & auxiliary relay products, unless otherwise stated, are warranted for a period of 24 months from shipment for materials & labour on a return to factory basis. Repair of products damaged through poor application or circumstances outside the product ratings will be carried out at the customers expense.

Standard Conditions of Sale

Unless otherwise agreed RMS Standard Terms & Conditions (QF 907) shall apply to all sales. These are available on request or from our web site.



Relay Monitoring Systems Pty Ltd

6 Anzed Court, Mulgrave, Victoria 3170, AUSTRALIA

Tel: 61 3 9561 0266 Fax: 61 3 9561 0277 Email: rms@rmspl.com.au Web: www.rmspl.com.au