

Reyrolle
Protection
Devices

7SG117 Argus 7

Synchronising Relay

Answers for energy

SIEMENS

7SG117 Argus 7

Synchronising Relay



Fig 1.

- Independent check & system synchronising settings
- Adjustable slip frequency, phase angle and voltage blocking
- Differential blocking
- Split system detection
- Configurable dead bus and/or dead line charge
- Integrated manual close guard feature
- Fibre optic or RS485 electrical comms port

Synchronising bypass logic is provided to connect a dead line or bus to a live line or bus. For manual synchronising the relay includes a circuit breaker close guard feature, which is used to prevent the control switch being held closed during a synchronising operation. This feature is implemented using internal logic and removes the need for an external relay.

Description

The 7SG117 Argus 7 is a combined check and system synchronising relay which can carry out controlled closing of a circuit breaker using measurements of the line and bus voltages. The relay will prevent closure of the circuit breaker if the differences in phase angle, slip frequency or magnitude of the voltages fall outside prescribed limits.

If the parameters are within limits, the relay will issue an output which can be used to close the circuit breaker directly or in conjunction with an autoreclose scheme.

Relays are part of the comprehensive range of Argus-platform based numeric relays. They have extensive control functions, which are supplemented by advanced metering, data storage and fibre-optic communications. Supervisory and self-monitoring features give added confidence to the user as well as reduced maintenance and down time. Reydsp relay interrogation software gives user-friendly access to relay settings, meters and operational data.

Function Overview

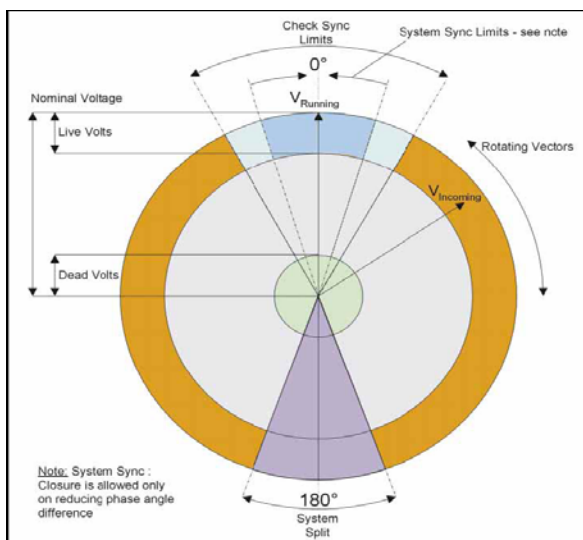

Monitoring Functions

Analogue values can be displayed in primary or secondary quantities on the LCD screen. In addition the values can be obtained via the communications port.

- Primary voltages
- Secondary voltages
- Frequencies
- Phase angles
- Status inputs
- Output contacts

Data Storage and Communication

Serial communications conform to IEC60870-5-103 protocol. Up to 254 relays may be connected in a ring network and addressed individually.

A fibre-optic communications port is provided on the rear of the relay. It is optimised for 62.5/125µm glass fibre using ST® (BFOC/2.5) bayonet connectors. Optionally an RS485 electrical connector can be provided.

Indication

LEDs for CHECK/SYS SYNCH, SYS SPLIT and PROTECTION HEALTHY status.

LCD – Alpha-numeric display for settings, instruments and fault data.

Sequence of event records

Up to 500 events are stored and time tagged to 1ms resolution. These are available via the communications.

Trip/Close records

The last 10 records are available from the fascia and via the data communications channel.

The record contains information for the time and date of close and the voltage, frequency and slip values at the time of close.

Disturbance recorder

The waveform recorder may be triggered from a synchronising function or external input and has a configurable pre-fault trigger.

Up to 5 a.c. voltage waveforms are stored. together with the digital states of the status inputs and output relays

Reydisp Evolution

Reydisp Evolution is common to the entire range of Reyrolle numeric products. It provides the means for the user to apply settings, interrogate settings and retrieve events and disturbance waveforms from the Relay.

Application

Check or system synchronising is required whenever two parts of a power system network, each containing generation, have to be connected or re-connected together. To avoid shock loading and possible damage to primary electrical plant the voltage, frequency and phase angle difference between the two systems should be within acceptable limits relative to one another.

Where the two systems have been previously interconnected, then the frequencies of the two systems will drift apart slowly following circuit breaker tripping and the phase angle difference will increase. Here the slip rate will be small and the circuit breaker can be closed using check synchronising settings as the limiting parameters.

However, if the two systems become asynchronous so one system is an 'island' of generation then a high rate of slip may result causing the two systems to pass through anti-phase conditions. The relay will detect this system split condition, inhibit the check synchronising algorithms and automatically apply system synchronising settings as limiting parameters. Typically in this mode the slip rate will be much higher and so there will be a narrower allowable phase angle difference before closing. In addition, closure of the circuit breaker will only be allowed under conditions of decreasing difference in phase angle.

Technical Data

For full technical data refer to the Performance Specification of the Technical Manual.

Inputs and Outputs

Voltage Inputs

AC Voltage	Frequency
63.5/110V	50 / 60Hz

Burden	< 0.2VA
Continuous Withstand	250V

DC Auxiliary supply

Rated DC Voltage	Operating Range V dc
24/30/48V	18 to 60V
110/220V	88 to 280V

Operate State	Burden
Quiescent (Typical)	3 W
Maximum	10 W

Allowable superimposed ac component	≤ 12% of dc voltage
Allowable breaks/dips in supply (collapse to zero from nominal voltage)	≤ 20 ms

DC status input

Nominal voltage	Operating range
30V	18 - 37.5 V D C
48V	37.5 - 60 V D C
110V	87.5 - 137.5 V D C
220V	175 - 280 V D C

Attribute	Value
Min. DC Current for Operation:	
30/48V	10mA
110/220V	<5mA
Reset/Operate voltage ratio	≥ 90 %
Typical response time	5 ms
Typical response time when programmed to energise an output relay contact	< 15 ms
Recommended Minimum pulse duration	40ms with setting of 20ms PU delay for a.c. rejection

The 30V and 48V inputs meet the requirements of the ESI48-4 ES1 standard. However, the 110V or 220V inputs will operate with a DC current of less than 10mA. If 110V or 220V inputs compliant with ESI48-4 ES1 are required, a 48 volt status input can be supplied with external dropper resistors as follows:

Nominal Voltage	Resistor Value	Wattage
110V	2k7 ± 5%	2.5 W
220 V	8k2 ± 5%	6.0 W

Each status input has associated timers which can be programmed to give time delayed pick-up and time delayed drop-off. The pick-up delays have default settings of 20ms, thus providing rejection and immunity to an AC input signal. Status inputs will not respond to the following:-

- 250V RMS 50/60Hz applied for two seconds through a 0.1 μ F capacitor.
- Discharge of a 10 μ F capacitor charged to maximum DC auxiliary supply voltage.

Output relays

Carry continuously	5A ac or dc
Make and carry (L/R \leq 40 ms and V \leq 300V)	20A ac or dc for 0.5s 30A ac or dc for 0.2s
Breaking Capacity (\leq 5 A and \leq 300 V): AC Resistive AC Inductive DC Resistive DC Inductive	1250 VA 250 VA at p.f. \geq 0.4 75 W 30 W at L/R \leq 40ms 50 W at L/R \leq 10ms
Minimum number of operations	10 ⁶ at maximum load
Minimum recommended load	0.5 W minimum of 10mA or 5V

Mechanical

Vibration (Sinusoidal)

IEC 60255-21-1 Class I

Vibration response	0.5gn	\leq 5% variation
Vibration endurance	1.0gn	

Shock and Bump

IEC 60255-21-2 Class I

Shock response	5gn, 11ms	\leq 5% variation
Shock withstand	15gn, 11ms	
10 gn, Bump test	10gn, 16ms	

Seismic

IEC 60255-21-3 Class I

Seismic Response	1gn	\leq 5% variation
------------------	-----	---------------------

Electrical Tests

Insulation IEC 255-5

IEC 255-5 rms levels for 1 minute

Between all terminals and earth for 1 minute	2.0 kV rms
Between independent circuits for 1 minute	2.0 kV rms

Across normally open contacts for 1 minute	1.0 kV rms
--	------------

High frequency disturbance

IEC 60255-22-1 class III

2.5kV longitudinal mode	$<$ 3% deviation
1.0kV transverse mode	

Electrostatic Discharge

IEC 60255-22-2 class III

8kV, Contact discharge	\leq 5% variation
------------------------	---------------------

Fast transient

IEC 255-22-4 class IV

4kV, 5/50ns, 2.5 kHz, repetitive	\leq 3% variation
----------------------------------	---------------------

Conducted RFI

IEC 60255-22-6 class IV

10 V, 0.15 to 80 MHz	\leq 5% variation
----------------------	---------------------

Conducted Limits

IEC 60255-25

Frequency Range	Limits dB(μ V)	
	Quasi-peak	Average
0.15 to 0.5 MHz	79	66
0.5 to 30 MHz	73	60

Radiated Limits

IEC 60255-25

Frequency Range	Limits at 10 m
	Quasi-peak, dB(μ V/m)
30 to 230 MHz	40
230 to 10000 MHz	47

RF Frequency Interference

IEC 60255-22-3

10 V/m, 80 to 1000 MHz	\leq 5% variation
------------------------	---------------------

Environmental

Temperature

IEC 68-2-1/2

Operating range	-10°C to +55°C
Storage range	-25°C to +70°C

Humidity

IEC 68-2-3

Operational test	56 days at 40°C and 95% RH
------------------	----------------------------

Performance

General Accuracy

Reference Conditions	
General	IEC 60255-3
Auxiliary supply	Nominal
Frequency	50Hz or 60Hz
Ambient temperature	20 °C

Accuracy Influencing Factors

Temperature		
-10 °C to +55 °C		≤ 5 % variation
Frequency		
47 Hz to 52 Hz	Level:	≤ 1 % variation
57 Hz to 62 Hz		
	Operating time:	≤ 1 % variation

Check and System Synchronising (25)

Live and Dead voltage level		
Dead Line/Bus	5.0 to 127.0 V step 0.5 V	
Live Line/Bus	10.0 to 132.0 V step 0.5 V	
Accuracy	Live operate	Live setting ± 1%
	Live reset	Dead setting ± 1%
	Dead operate	Dead setting ± 1%
	Dead reset	Live setting ± 1%
Undervoltage level		
Setting	22.0 to 132.0 V step 0.5V	
Accuracy	Operate	Setting ± 1%
	Reset	< 104% of operate level
Voltage difference level		
Setting	0.5 to 44.0 V step 0.5V	
Accuracy	Operate	Setting ± 2% or 0.5 V
	Reset	> 90% of operate level or > operate level – 2.0V
Slip Frequency		
Setting	20 to 2000 mHz step 5 mHz	
Accuracy	Operate	Setting – 15mHz + 0mHz
	Reset	Operate – 0mHz + 15mHz
Check Sync., System Sync. Phase angle		
Setting	5 to 90° step 1°	
Accuracy	Operate	Setting - 3° + 0°
	Reset	Operate - 0° + 3°
System Split phase angle		
Setting	90 to 175° step 1°	
Accuracy	Operate	Setting ± 1.5°
	Reset	Latched
All timers		
Setting	0.1 to 100.0 sec step 0.1 sec	
Accuracy	± 1% or 10ms	

Case Dimensions

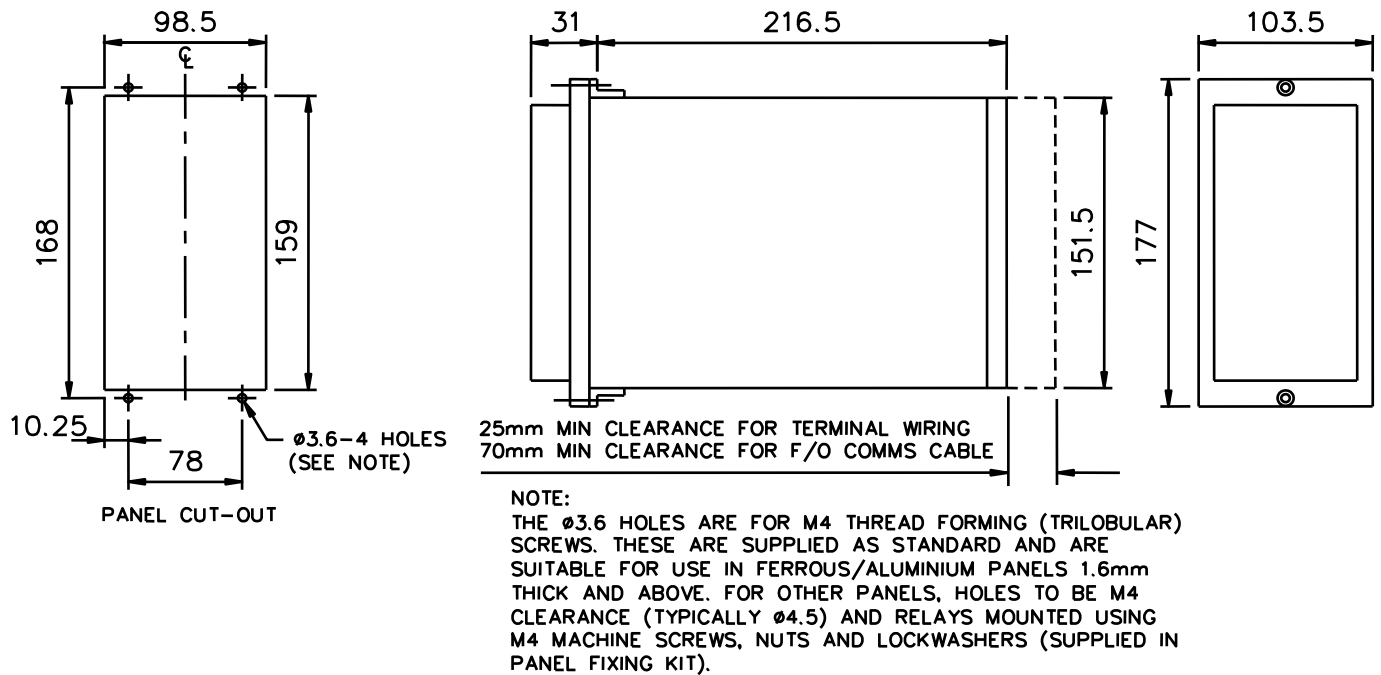

Fig 2. E4 Case Dimensions

Connection Diagram

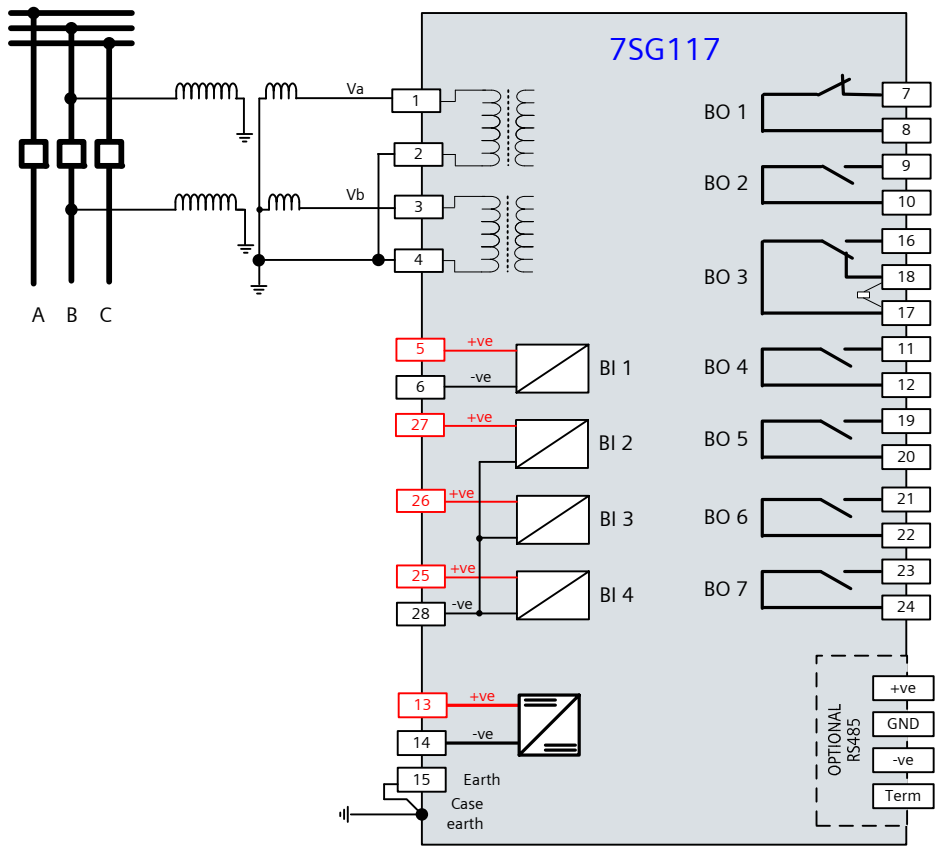

Fig 3. Connection Diagram for 7SG117 Synchronising Relay

Ordering Information – 7SG117

Product description	Variants	Order No.
---------------------	----------	-----------

Check and system synchronising relay

Number of elements

Two pole relay

Auxiliary supply /binary input voltage

- 24/30/48 V DC auxiliary, 30 V binary input
- 110/220 V DC auxiliary, 30 V binary input
- 24/30/48 V DC auxiliary, 48 V binary input
- 110/220 V DC auxiliary, 48 V binary input ¹⁾
- 110/220 V DC auxiliary, 110 V low burden binary input
- 110/220 V DC auxiliary, 220 V low burden binary input

Type of voltage relay

Voltage measuring relay providing check and system synchronising

Nominal voltage inputs

63/110 V AC

I/O range

4 Binary Inputs / 7 Binary Outputs (incl. 1 changeover and 1 normally closed)

Communication interface

- Fibre optic (ST-connector) / IEC 60870-5-103
- RS485 interface / IEC 60870-5-103

Housing size

Case size E4 (4U high)

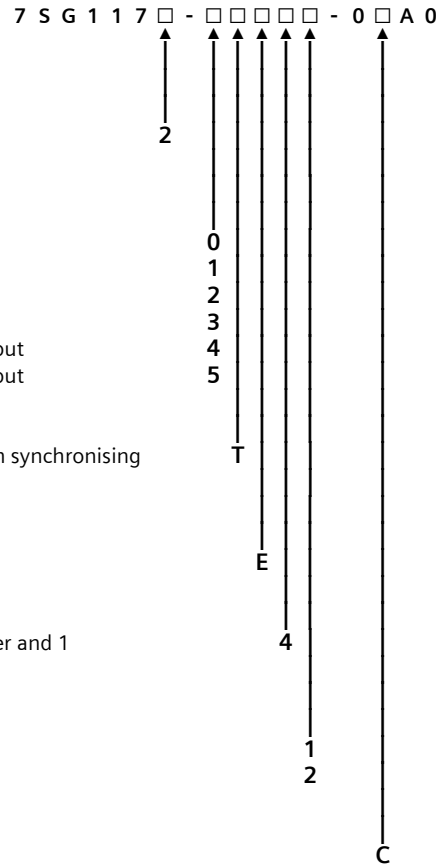

¹⁾ High burden 110V & 220V binary inputs compliant with ESI48-4 ESI 1 available via external dropper resistors with 48V binary input version
 for 5 binary inputs and 110V application, order resistor box VCE:2512H10065 in addition
 for 5 binary inputs and 220V application, order resistor box VCE:2512H10067 in addition
 Refer to website for application note about ESI48-4 compliance

