

Reyrolle  
Protection  
Devices

## **7SG12 DAD N**

Numerical High Impedance

**Answers for energy**

**SIEMENS**

# 7SG12 DAD N

Numerical high Impedance



## Description

The 7SG12 DAD-N overall differential protection uses the high impedance circulating current principle; a single line diagram of such a scheme is shown in fig. 1.

The 7SG12 is a three phase relay providing high-speed, high impedance phase segregated current differential protection and phase segregated open circuit monitoring of the current transformer secondary circuits (CT supervision). Outputs from the differential and CT supervision elements operate when their input current exceeds their individual current settings. The programmed time delays, LEDs and output contacts are initiated.

Relays can be supplied with binary input/output and LED combinations as follows:

- 3BI + 5BO + 16 LEDs, E8 case
- 11BI + 13BO + 16 LEDs, E8 case
- 19BI + 21BO + 32LEDs, E12 case
- 27BI + 29BO + 32LEDs, E12 case.

All output contacts are fully programmable to any relay function listed in the output relay menu. Output relays can be configured as self reset or hand reset.

It is recommended that class 'PX' current transformers to IEC 60044-1 are used with high impedance protection.

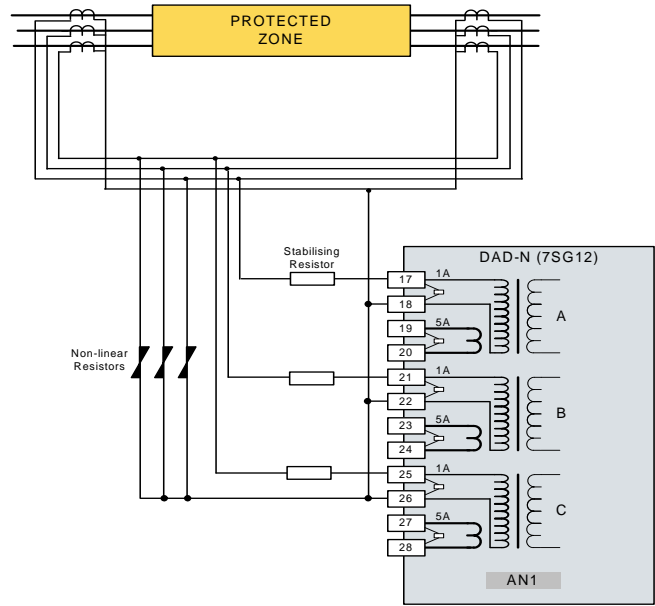

Fig 1. Simplified Typical A.C. Schematic Diagram

## Function Overview

- High speed phase segregated differential protection
- Harmonic rejection
- Integrated open circuit current transformer monitoring
- Continuous self monitoring
- Compatibility with generic communications software
- Reydisp Evolution
- Settings stored in EEPROM
- Storage of up to 500 time tagged event records
- Storage of up to 10 waveform records in non-volatile memory without the use of batteries.
- Metering of analogue and digital quantities.
- Expandable I/O of up to 27 binary inputs and 29 output contacts replaces the need for external trip lockout relays.
- Programmable LEDs for trip and alarm conditions. E8 or E12 case.

## User Interface

- 20 character x 2 line backlit LCD
- Menu navigation keys
- 1 fixed LED.
- 16 or 32 programmable LEDs.

## Monitoring Functions

Monitored quantities can be displayed on the LCD screen or via the data communications channel(s). Monitored values include:-

- Differential currents
- Binary inputs
- Output relays

## Application

Typically applied to provide 3 – phase high impedance differential protection of busbar, connections, auto-transformers, reactors and motors, see figure 4.

High impedance protection is recommended for all applications where faults must be cleared in the shortest possible time and where discrimination must be ensured. High impedance schemes can provide lower fault settings and better through fault stability than is possible with most other schemes.

The stability of the high impedance scheme depends upon the operate voltage setting being greater than the maximum voltage which can appear across the relay under a given through fault condition. An external series stabilising resistor and shunt non-linear resistor per phase complete the scheme. The series resistor value is determined by the voltage level required for stability and the value of relay current calculated to provide the required primary fault setting. Non-linear resistors protect the relay circuit from high over-voltages.

The current setting and the operating voltage of the relay/stabilising resistor combination is calculated taking into account:-

- Transient stability under through fault conditions as verified by calculation assuming worst case conditions.
- The required operate level for internal fault conditions.

The CT supervision function of the DAD-N relay provides monitoring of CT secondary wiring connections, this is particularly relevant where current transformer wiring is switched as in some busbar protection arrangements.

## Theory of High Impedance Current Balance Protective Schemes and their Application

### Determination of Stability

The stability of a current balance scheme using a high impedance relay circuit depends upon the relay voltage setting being greater than the maximum voltage which can appear across the relay under a given through fault condition. This maximum voltage can be determined by means of a simple calculation which makes the following assumptions:

One current transformer is fully saturated making its excitation impedance negligible.

The resistance of the secondary winding of the saturated current transformer together with the leads connecting it to the relay circuit terminals constitute the only burden in parallel with the relay.

The remaining current transformers maintain their ratio.

Thus the maximum voltage is given by:

$$(1) \quad V = I_{\max} (R_{CT} + R_L)$$

Where:

$R_L$  = The largest value of pilot loop Resistance between the current transformer and the relay circuit terminals

$R_{CT}$  = Current transformer secondary winding resistance

$I_{\max}$  = Current transformer secondary current corresponding to the maximum steady state through fault current of the protected equipment.

For stability, the voltage setting of the relay  $V_s$  must be made equal to or exceed, the highest value of  $V$  calculated above.

Experience and extensive laboratory tests have proved that if this method of estimating the relay setting voltage is adopted, the stability of the protection will be very much greater than the value of  $I$  used in the calculation. This is because a current transformer is normally not continuously saturated and consequently any voltage generated by this current transformer will reduce the voltage appearing across the relay circuit.

### Method of Establishing Relay Setting Current

Relay setting current is given by:

$$(2) I_S = I_F - (\sum I_{mag} + I_{NLR})$$

Where:

$I_S$  = Relay setting current

$I_F$  = Current transformer secondary current at the primary fault setting required i.e. at  $V_s$ .

$\sum I_{mag}$  = Current transformer magnetising currents at the value of  $V_s$ .

$I_{NLR}$  = Current taken by the non-linear resistor/voltage limiting device at  $V_s$  (this value is usually small and often may be neglected).

Equation (2) should properly be the vector sum, however arithmetic addition is normally used.

### Establishing the Value of Setting Resistors

Resistor value R is given by:

$$(3) R = \frac{V_s}{I_S}$$

Exact resistor values are not necessary, a higher resistor standard value may be chosen provided a check calculation using that value shows sufficient margin i.e.:

$$(4) V < V_{actual\ Setting} < 0.5V_{CT\ knee\ point}$$

The required watt-second rating of the resistor is established at setting and at the maximum fault rating – short time rating. Stabilising resistors should be mounted vertically in a well ventilated location and clear of all other wiring and equipment to avoid the effects of their power dissipation

## Data Storage and Communication

### Sequence of event records

Up to 500 events are stored and time tagged to 1ms resolution. These are available via the communications.

### Fault records

The last 10 fault records are available from the fascia with time and date of trip, measured quantities and type of fault.

### Disturbance recorder

5 seconds of waveform storage is available and is user-configurable as 5 x 1s or 1 x 5s records. Within the record the amount of pre-fault storage is also configurable. The recorder is triggered from a protection operation, or binary input. ( e.g. Buchholz flag indication).

The records contain the analogue waveforms of the line currents and the digital input and output signals.

The relay settings must be appropriately programmed in order for a wave form to be triggered from an external protection device.

### Communications

Two fibre-optic communications ports are provided on the rear of the relay. They are optimised for 62.5/125µm glass-fibre, with BFOC/2.5 (ST®) bayonet style connectors.

In addition users may interrogate the relay locally with a laptop PC and the RS232 port on the front of the relay.

The relay can be user selectable to either IEC 60870-5-103 or Modbus RTU as its communications standard.

### Reydisp evolution

Reydisp Evolution is common to the entire range of Reyrolle numeric products, providing means for the user to apply settings to the relay, interrogate settings and retrieve stored data records.

Reydisp evolution utilises IEC 60870-5-103 protocol.

## Settings

### Current Inputs

Description	Range	Default
87/50 Element	Disabled, Enabled	Disabled
87/50 Setting	0.005, 0.006 ...0.100I <sub>n</sub> 0.105, 0.110 ...2.000I <sub>n</sub>	0.5xI <sub>n</sub>
87/50 Delay	0,0.01...60s	0.00s
CT 50 Element	Disabled, Enabled	Disabled
CT 50 Setting	0.001, 0.002 ...0.100I <sub>n</sub> 0.105, 0.110 ...2.000I <sub>n</sub>	0.10xI <sub>n</sub>
CT 50 Delay	0.1,0.2...60s	10.00s

## Technical Data

For full technical data refer to the Performance Specification Section

## Inputs and Outputs

### DC Power Supply

Nominal	Operating Range
30V	24V to 37.5V dc
48/110V	37.5V to 137.5V dc
220V	175V to 286V dc

### Auxiliary DC Supply – IEC 60255-11

Allowable superimposed ac component	≤ 12% of DC voltage
Allowable breaks/dips in supply (collapse to zero from nominal voltage)	≤ 20ms

### D.C. Burden

Quiescent (Typical)	15
Max	27

### Binary Input

Nominal Voltage	Operating Range
30V	18V to 37.5V
48V	37.5V to 60V
110V	87.5V to 137.5V
220V	175 to 280V

### Performance

Minimum DC current for operation	48V 10mA 110V 2.25mA 220V 2.16mA
Reset/Operate Voltage Ratio	≥90%
Typical response time	<5ms
Typical response time when programmed to energise an output relay contact	<15ms
Minimum pulse duration	40ms

### Output Contacts

Contact rating to IEC 60255-0-2  
Carry continuously 5A ac or dc

### Make and Carry

(limit L/R ≤ 40ms and V ≤ 300 volts)

For 0.5 sec	20A ac or dc
For 0.2 sec	30A ac or dc

### Break

(limit ≤ 5A or ≤ 300 volts)

Ac resistive	1250VA
Ac inductive	25VA @ PF ≤ 0.4
Dc resistive	75W
Dc inductive	30W @ L/R ≤ 40 ms 30W @ L/R ≤ 40 ms

Minimum number of operations	1000 at maximum load
Minimum recommended load	0.5W, limits 10mA or 5V

## Mechanical

### Vibration (Sinusoidal)

IEC 60255-21-1 Class 1

		Variation
Vibration response	0.5gn	≤ 5%
Vibration endurance	1.0gn	≤ 5%

### Shock and Bump

IEC 60255-21-2 Class 1

		Variation
Shock response	5 gn 11ms	≤ 5%
Shock withstand	15 gn 11ms	≤ 5%
Bump test	10 gn 16ms	≤ 5%

Seismic IEC 60255-21-3 Class 1

		Variation
Seismic Response	1gn	≤ 5%

### Mechanical Classification

Durability	In excess of 10 <sup>6</sup> operations
Ambient range	-10°C to +55°C
Variation over range	≤ 5%

## Electrical Tests

### Transient Overvoltage

IEC 60255-5

Between all terminals and earth or between any two independent circuits without damage or flashover	5kV 1.2/50µs 0.5J
---	-------------------

### Insulation

IEC 60255-5

Between all terminals and earth	2.0kV rms for 1 min
Between independent circuits	2.0kV rms for 1 min
Across normally open contacts	1.0kV rms for 1 min

### High Frequency Disturbance

IEC 60255-22-1 Class III

	Variation
2.5kV Common (Longitudinal) Mode	≤ 5%
1.0kV Series (Transverse) Mode	≤ 5%

### Electrostatic Discharge

IEC 60255-22-2 Class IV

	Variation
8kV contact discharge	≤ 5%

### Conducted & Radiated Emissions

EN 55022 Class A (IEC 60255-25)

Conducted	0.15MHz – 30MHz
Radiated	30MHz – 1GHz

### Conducted Immunity

(IEC 61000-4-6; IEC 60255-22-6)

	Variation
0.15MHz – 80MHz 10V rms 80% modulation	≤ 5%

### Radiated Immunity

IEC60255-22-3 Class III

	Variation
80MHz to 1000MHz, 10V/m 80% modulated	≤ 5%

### Fast Transient

IEC 60255-22-4 Class IV

	Variation
4kV 5/50ns 2.5kHz repetitive	≤ 5%

### Surge Impulse

IEC 61000-4-5 Class IV; (IEC 60255-22-5)

	Variation
4KV Line-Earth (O/C Test voltage 10%) 2KV Line-Line	≤ 10

## Environmental

### Temperature

IEC 60068-2-1/2

Operating range	-10°C to +55°C
Storage range	-25°C to +70°C

### Humidity

IEC 60068-2-3

Operational test	56 days at 40°C and 93% RH
------------------	----------------------------

## Protection Elements

### General Accuracy

Reference Conditions	
General	IEC60255 Parts 6, 6A & 13
Auxiliary	Nominal
Frequency	50/60Hz
Ambient Temperature	20°C

### Accuracy influencing factors

Temperature	
10 °C to +55 °C	≤ 5% variation
Frequency	
47 Hz to 52 Hz	Setting: ≤5% variation
57 Hz to 62 Hz	Operate Time: ≤ 5% variation

### 87/50-1, 87/50-2 Differential

Pickup	± 5% of setting or ± 0.01 I <sub>n</sub> whichever is the greater
Reset	0.95% of I <sub>s</sub>
Repeatability	± 2%
Operate Time 2 x Setting 4 x Setting	Operate Time 1 cycle ± 5ms < 1 cycle
Time Delay	± 1% or ± 5ms whichever is the greater

### CT-50 CT Supervision

Pickup	± 5% of setting or ± 0.01 I <sub>n</sub> whichever is the greater
Reset	0.95% of I <sub>s</sub>
Repeatability	± 2%
Operate Time 2 x Setting	Operate Time < 1.5 cycles
Time Delay	Time Delay setting +/- 5% or +/- 10 milliseconds, whichever is the greater**

## Case Dimensions

The 7SG12 is supplied in either a size 8 or size 12 case, depending on the binary input and output relay requirement.

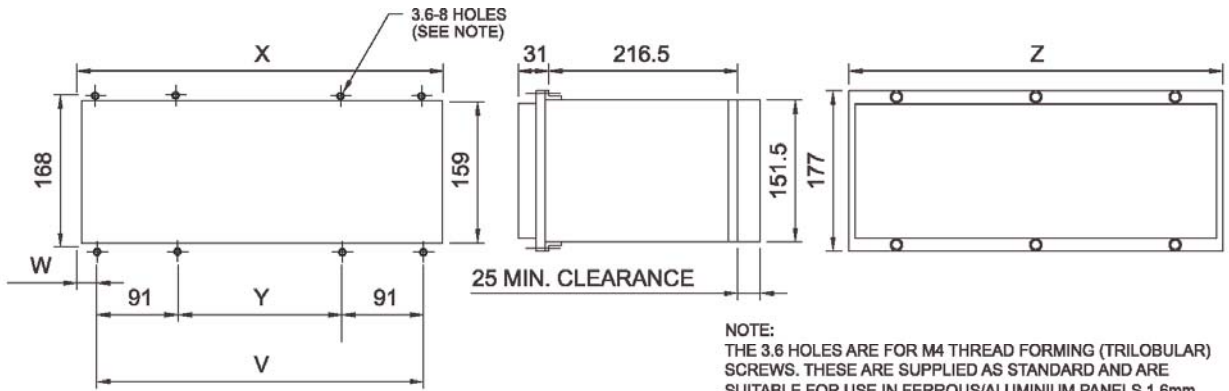

**Overall Dimensions and panel drilling for Epsilon E12 case**

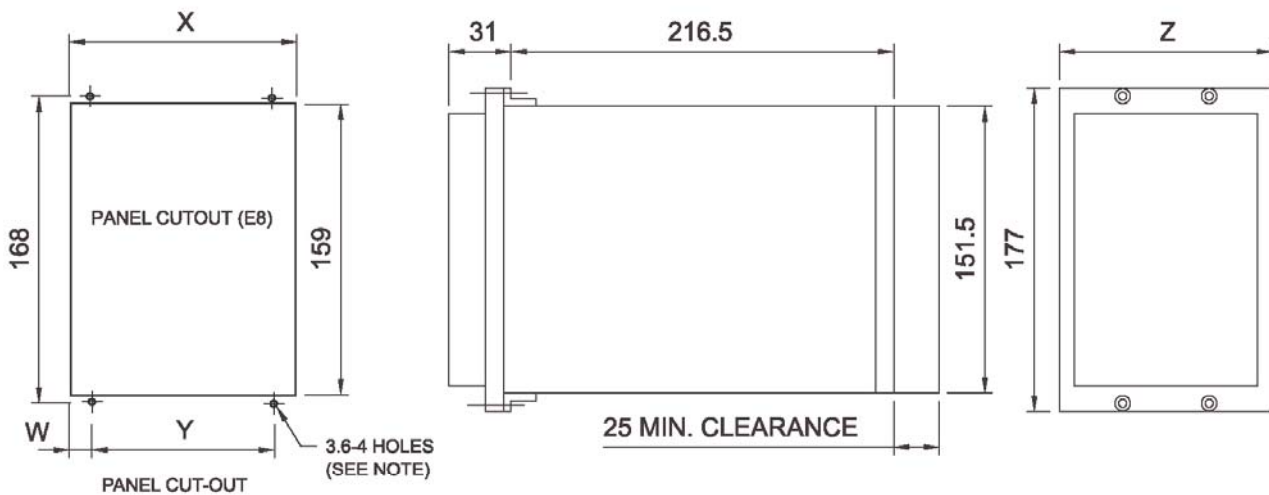

**Overall Dimensions and panel drilling for Epsilon E8 case**

	E8	E12
V	-	286
W	9.75	9.25
X	201.5	304.5
Y	182	104
Z	207.5	311.5

**All dimensions are in Millimetres**

Fig 2. Case Dimensions

# Connection Diagram

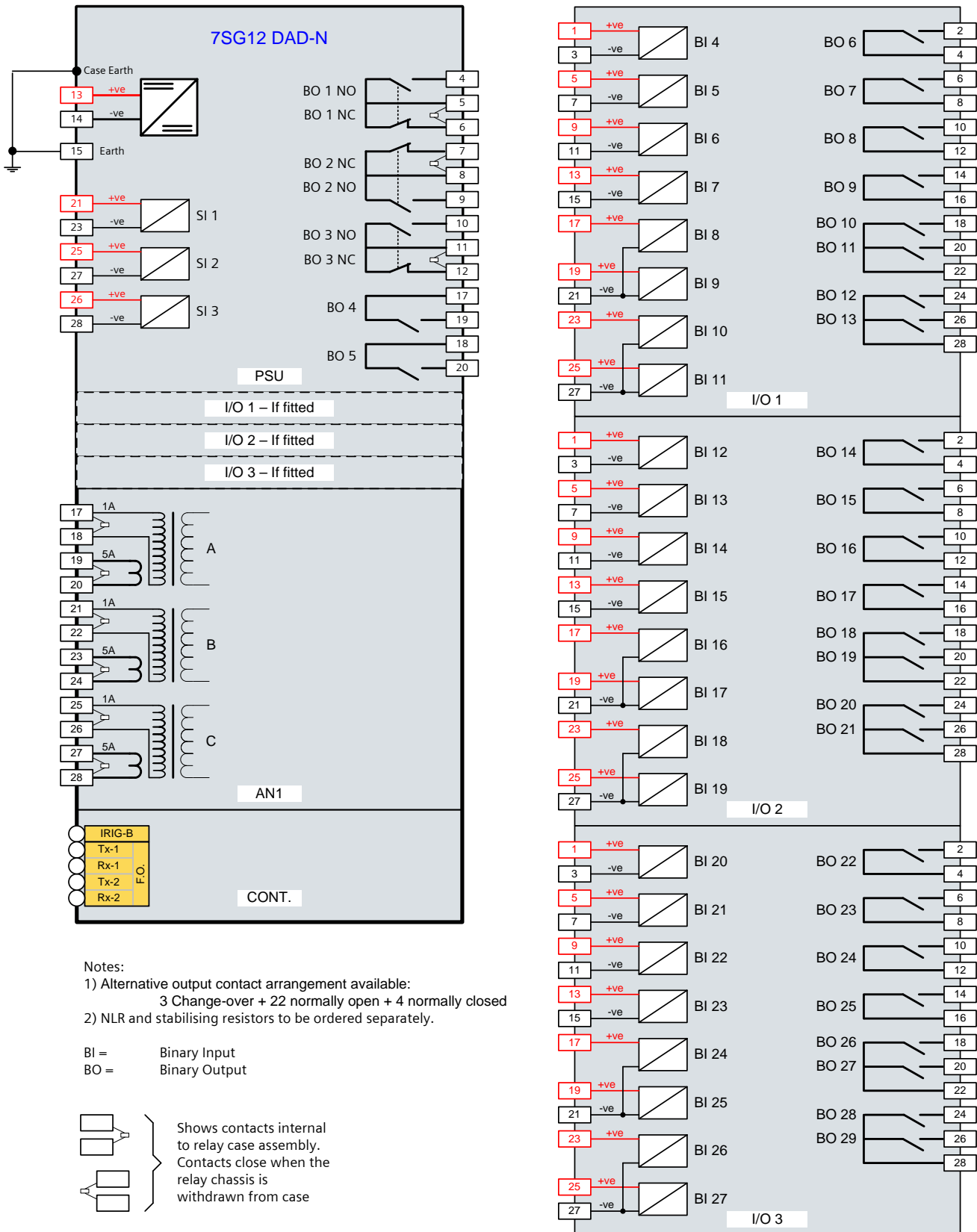
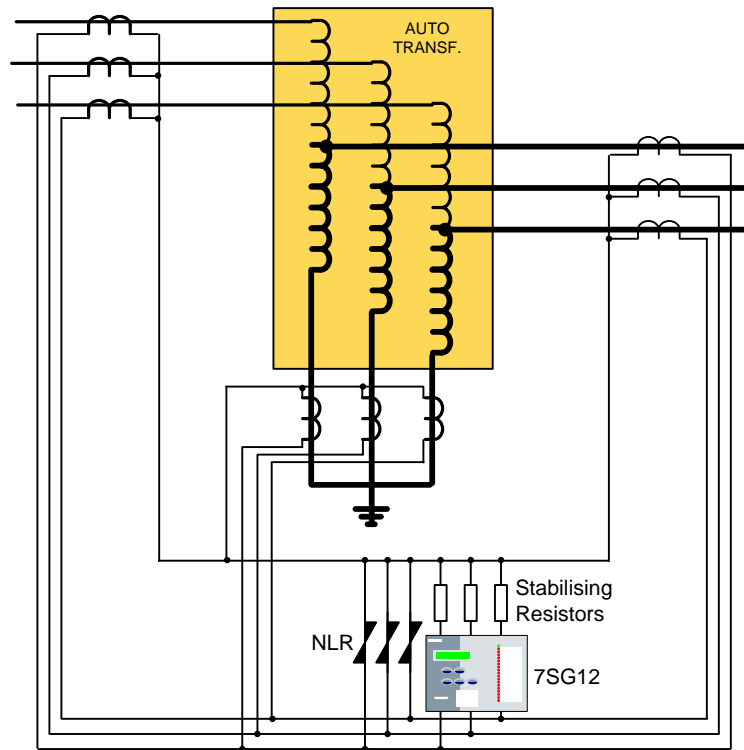
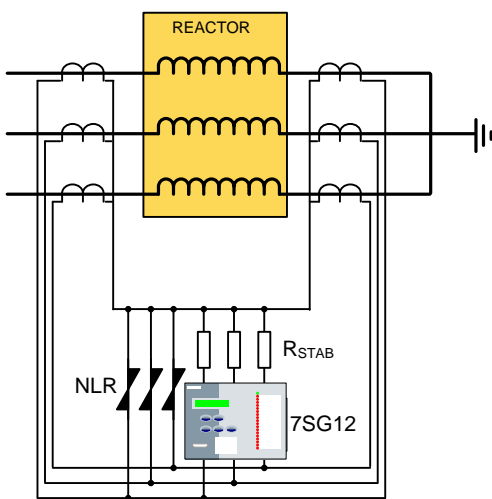

Fig 3. Connection Diagram for 7SG1211 Relay

# Typical Applications



a) AUTO-TRANSFORMER



b) MOTOR or GENERATOR or REACTOR

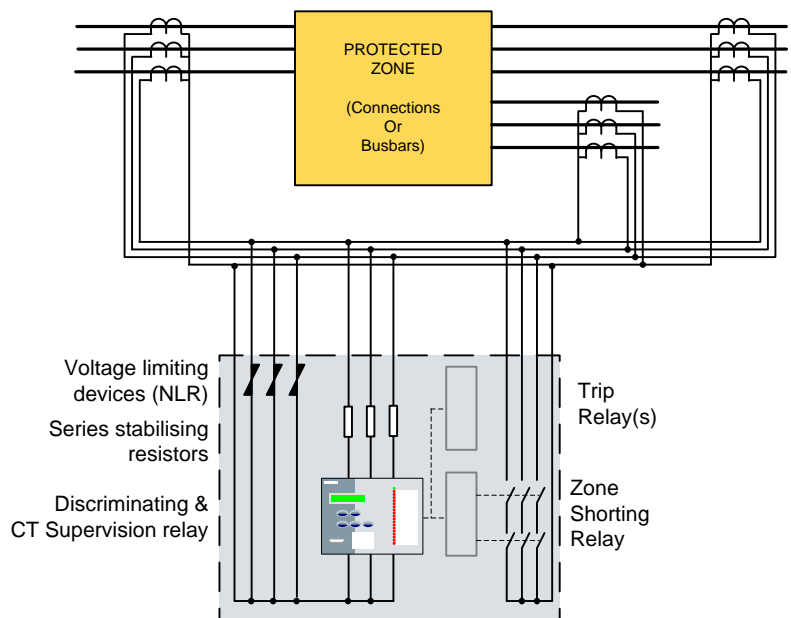

c) TYPICAL BUSBAR PROTECTION SCHEME COMPONENTS

Fig 4. Typical Applications of 7SG1211 Relay

# Ordering Information – 7SG12 DAD-N

Product description	Variants	Order No.
---------------------	----------	-----------

## Nondirectional O/C Relay

Numeric high impedance circulating current protection.

Relay type  
100 series - High Impedance Circulating Current Protection

Protection options  
Option 01  
- CT supervision (CT50)  
- Overall differential (87/50-1, 87/50-2)

Auxiliary supply /binary input voltage  
30 V DC auxiliary, 30 V DC binary input  
30 V DC auxiliary, 48 V DC binary input  
48/110 V DC auxiliary, 30 V DC binary input  
48/110 V DC auxiliary, 48 V DC binary input <sup>1)</sup>  
48/110 V DC auxiliary, 110 V DC low burden binary input  
220 V DC auxiliary, 110 V DC low burden binary input  
220 V DC auxiliary, 220 V DC low burden binary input

I/O range <sup>1)</sup>  
3 Binary Inputs / 5 Binary Outputs (incl. 3 changeover)  
11 Binary Inputs / 13 Binary Outputs (incl. 3 changeover)  
19 Binary Inputs / 21 Binary Outputs (incl. 3 changeover)  
27 Binary Inputs / 29 Binary Outputs (incl. 3 changeover)

Frequency  
50Hz  
60Hz

Nominal current  
1/ 5 A

Housing size  
Case size E8 (4U high)  
Case size E12 (4U high)  
Case size E12 (4U wide, vertical)

Communication interface  
Fibre optic (ST-connector) / IEC 60870-5-103 or Modbus RTU

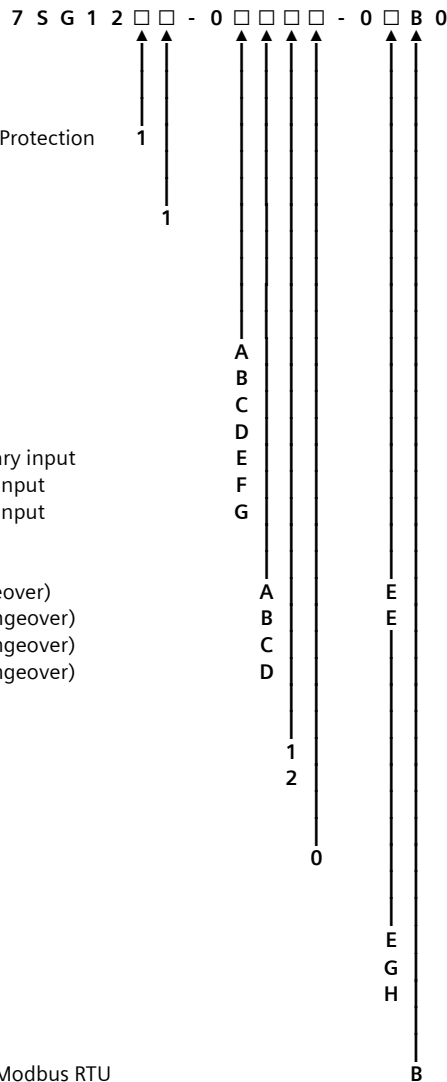

<sup>1)</sup> High burden 110V & 220V binary inputs compliant with ESI48-4 ESI 1 available via external dropper resistors with 48V binary input version  
110/125 V application, order combination of the following resistor boxes to suit number of binary inputs  
VCE:2512H10064 (9 inputs, 110V)  
VCE:2512H10065 (5 inputs, 110V)  
VCE:2512H10066 (1 inputs, 110V)  
220/250 V application, order resistor box VCE:2512H10066 in addition  
VCE:2512H10067 (5 inputs, 220V)  
VCE:2512H10068 (1 inputs, 220V)

Refer to website for application note about ESI48-4 compliance

