

Reyrolle  
Protection  
Devices

## **7SG17 Rho 3**

Motor Protection Relay

**Answers for energy**

**SIEMENS**



# 7SG17 Rho 3

Motor Protection Relay



- Earth fault trip inhibit for contactor control application
- Status inputs with programmable independent pickup and drop off timers.

## User Interface

### Indication

16 character x 2 line backlit LCD  
Menu navigation keys  
LEDs for TRIP, MOTOR STARTING, MOTOR RUNNING, STARTER and PROTECTION HEALTHY status.

## Description

The 7SG17 Rho 3 is a multi-function numerical Motor Protection relay suitable for all types of a.c. induction motors up to the highest ratings available. Whilst medium voltage 3-phase motors are very reliable and robust, modern designs operate much closer to the limits of thermal margins and to give adequate protection, sophisticated protection relays are required. In addition, increased industrial use of power electronics leads to corruption of power systems and unless specific equipment is installed to eliminate the corruption it can cause considerable rotor overheating. The relay has been designed to protect the motor against these phenomena as well as known abuses such as mechanical overload, stalling, single phasing, terminal box and cabling failures, and too frequent starts. The relay can be set to accurately mimic both the heating and cooling characteristics of the protected motor and consequently ensure that the thermal withstand of the machine is not exceeded, at the same time allowing full use of the motors thermal capability.

## Function Overview

- Advanced motor protection - for medium voltage motors
- Easily programmable settings and user interface
- Thermal overload and restart inhibit protection
- Stall and locked rotor protection
- Short circuit and earth fault protection
- Phase unbalance protection
- Undercurrent detection
- Limitation of number of starts
- Optional thermistor or resistance temperature detector (RTD) inputs
- Circuit breaker fail
- Trip circuit supervision
- CT supervision

## Monitoring Functions

Monitored quantities can be displayed on the LCD screen or via the communications port. Monitored values include:-

- Primary/secondary currents
- Motor full load current
- PPS & NPS currents
- Thermal equivalent current
- Phase difference current
- Motor status (Stopped, running)
- Time to trip
- Time to start
- Thermal capacity used
- Total starts
- Last start time
- Last start current
- Motor run time
- Total run time
- Maximum demand/time
- Output relay status
- Status inputs
- Trip circuit healthy/failure
- Trip counters
- I<sup>2</sup> summation
- Number of waveform and event records stored
- Time and Date

## Data Storage and Communication

Serial communications conform to IEC60870-5-103 or Modbus RTU protocol. Up to 254 relays may be connected in a ring network and addressed individually. A fibre-optic communications port is provided on the rear of the relay. It is optimised for 62.5/125µm glass fibre using ST® (BFOC/2.5) bayonet connectors. Optionally an RS485 electrical connector can be provided.

### Sequence of event records

Up to 500 events are stored and time tagged to 1ms resolution. These are available via the communications.

### Fault records

The last 5 fault records are available from the fascia with time and date of trip, measured quantities and type of fault.

### Disturbance recorder

The waveform recorder may be triggered from a protection function or external input and has a configurable pre-fault trigger. Up to 5 fault waveforms may be stored. AC voltage waveforms are stored together with the digital states of the binary inputs and output relays..

### Reydisp evolution

Reydisp Evolution is common to the entire range of Reyrolle numeric products, providing means for the user to apply settings to the relay, interrogate settings and retrieve stored data records.

Reydisp evolution utilises IEC 60870-5-103 protocol.

## Settings

### Settings

Thermal ( $I_0$ )	0.5 to 2.0 x $I_n$ , $\Delta$ 0.05
NPS weight (K)	0.0 to 10.0, $\Delta$ 0.1
Heating time ( $t_h$ )	0.5 to 100.0mins, $\Delta$ 0.5
Starting constant ( $t_s$ )	0.5 to 1.5 x $t_h$ , $\Delta$ 0.05
Cooling constant ( $t_c$ )	1 to 100 x $t_h$ , $\Delta$ 1
Hot/cold ratio	OFF, 5 to 100%, $\Delta$ 5
Start current	1.5 to 10.0 x $I_n$ , $\Delta$ 0.1
Stop current	0.05 to 0.2 x $I_n$ , $\Delta$ 0.05
Stall delay 1&2	1 to 250 seconds, $\Delta$ 1
Phase fault	0.5 to 20.0 x $I_n$ , $\Delta$ 0.1
Earth fault	0.01 to 1.00 x $I_n$ , $\Delta$ 0.01
Earth fault inhibit	4.0 to 10.0 x $I_n$ , $\Delta$ 0.1
Undercurrent	0.10 to 1.5 x $I_n$ , $\Delta$ 0.05
Phase unbalance	Phase difference, NPS, OFF
Phase difference	0.05 to 0.40 x $I_0$ , $\Delta$ 0.05
Negative sequence	0.05 to 0.40 x $I_0$ , $\Delta$ 0.05
Time multiplier	0.025 to 2.0, $\Delta$ 0.025
Minimum op time	0.1 to 2.0 secs, $\Delta$ 0.1
Max. number of starts	OFF, 1 to 20, $\Delta$ 1
Starts period	1 to 60 mins, $\Delta$ 1
Start inhibit delay	1 to 60 mins, $\Delta$ 1
Min. time between starts	OFF, 1 to 60 mins, $\Delta$ 1
Temperature (optional)	OFF, 0 to 250°C, $\Delta$ 1 <sup>(1)</sup> 100 to 350W, $\Delta$ 1 <sup>(2)</sup> 100 to 1000W, $\Delta$ 10 <sup>(3)</sup> 1100 to 30000W, $\Delta$ 100 <sup>(3)</sup>

(1) Named RTD setting range

(2) Other RTD setting range

(3) Thermistor setting range

## Technical Data

For full technical data refer to the Performance Specification of the Technical Manual.

## Inputs and Outputs

### Characteristic energising quantity

AC Current	Frequency
1A / 5A	50 / 60Hz

### Current Inputs: Burdens

5A Phase	< 0.2VA
1A Phase	< 0.05VA
5A Earth	< 0.4VA
1A Earth	< 0.2VA

### DC Auxiliary supply

Nominal voltage	Operating Range V dc
24/30/48V	18 to 60V
110/220V	88 to 280

### Auxiliary supply: Burdens

Quiescent (Typical)	3 W
Maximum	10 W

### DC status input

Nominal voltage	Operating range
30V	18 - 37.5 V D C
48V	37.5 - 60 V D C
110V	87.5 - 137.5 V D C
220V	175 - 280 V D C

For relays to ES148-4 standard and 110/125 or 220/250 volt DC working a 48 volt status input is supplied for use with external dropper resistors:

Nominal Voltage	Resistor Value	Wattage
110V	2k7 ± 5%	2.5 W
220 V	8k2 ± 5%	6.0 W

### Output relays

7 programmable output relays are available, 3 of which have a c/o contact and the other 4 have a n/o contact.

### Contact ratings

Carry continuously	5A AC or DC
Make and carry	30A AC or DC for 0.2 sec
Resistive break	75W DC, 1250VA A C

## Mechanical

### Vibration (Sinusoidal)

IEC 60255-21-1 Class I

Vibration response	0.5gn
Vibration endurance	1.0gn

### Shock and Bump

IEC 60255-21-2 Class I

Shock response	5gn, 11ms
Shock withstand	15gn, 11ms
10 gn, Bump test, 16ms	10gn, 16ms

### Seismic

IEC 60255-21-3 Class I

Seismic Response	1gn
------------------	-----

### Mechanical Classification

Durability	In excess of 10 <sup>6</sup> operations
------------	---

### Weight

Rho 3	4.7kg
Rho 3+RTD	6.7kg

## Electrical Tests

### Insulation IEC 255-5

RMS levels for 1 minute

Between all terminals and earth for 1 minute	2.0 kV
Between independent circuits for 1 minute	2.0 kV
Across normally open contacts for 1 minute	1.0 kV

### Transient overvoltage

IEC 255-4 class III

5kV 1.2/50µs 0.5J (terminals and earth)	No damage or flashover.
---	-------------------------

### High frequency disturbance

IEC 255-22-1 class III

2.5kV common mode	≤ 3% deviation
1.0kV series mode	≤ 3% deviation

## Electrostatic Discharge

*IEC 255-22-2 class III*

8kV contact discharge	≤ 5% deviation
-----------------------	----------------

## Radio frequency disturbance

*IEC 255-22-3*

20MHz to 1GHz, 10V/m	≤ 5% deviation
----------------------	----------------

## Fast transient

*IEC 255-22-4 class IV*

4kV 5/50ns 2.5kHz repetitive	≤ 3% deviation
---------------------------------	----------------

# Environmental

## Temperature

*IEC 68-2-1/2*

Operating range	10°C to +55°C
Storage range	25°C to +70°C

## Humidity

*IEC 68-2-3*

Operational test	56 days at 40°C and 93% RH
------------------	-------------------------------

## Case Dimensions

The 7SG17 is supplied in either a size 6 or size 8 case, depending on the binary input, RTD input and output relay requirement.

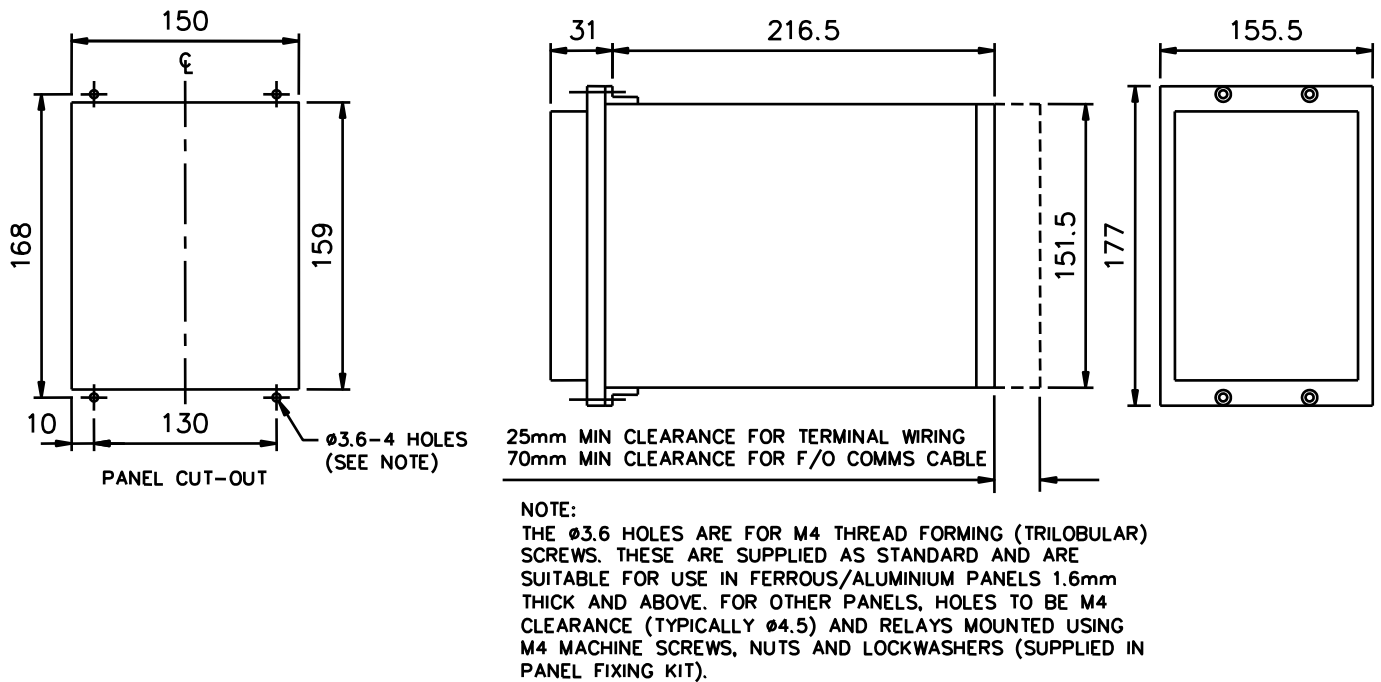

Fig 1. E6 Case Dimensions

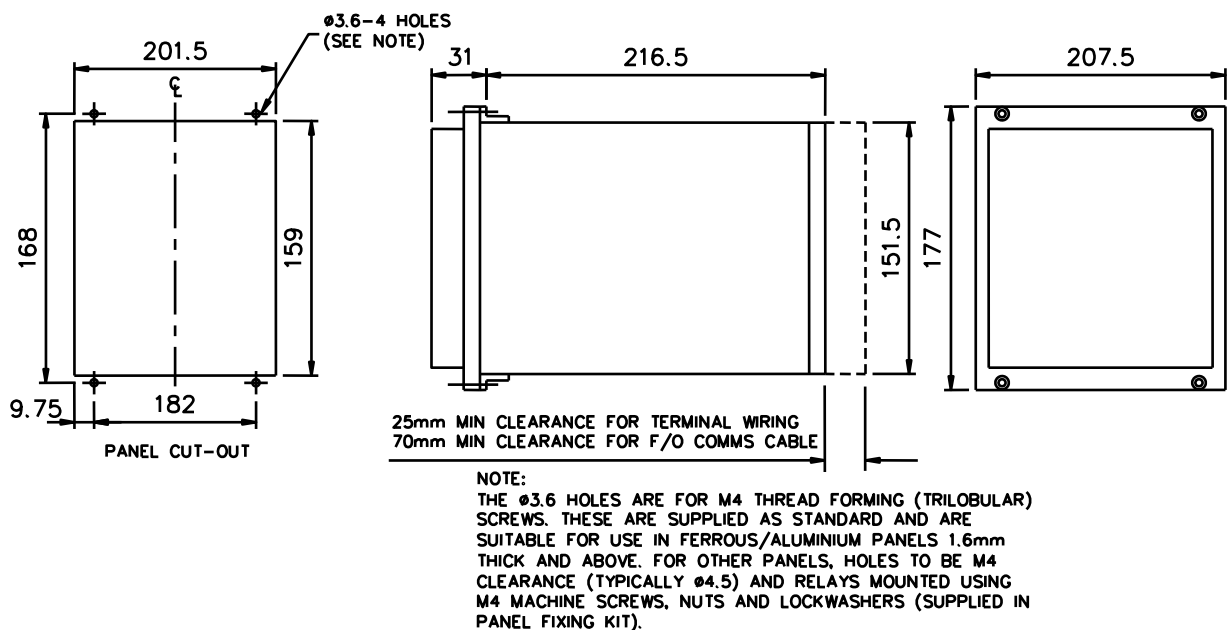

Fig 2. E8 Case Dimensions

# Connection Diagram

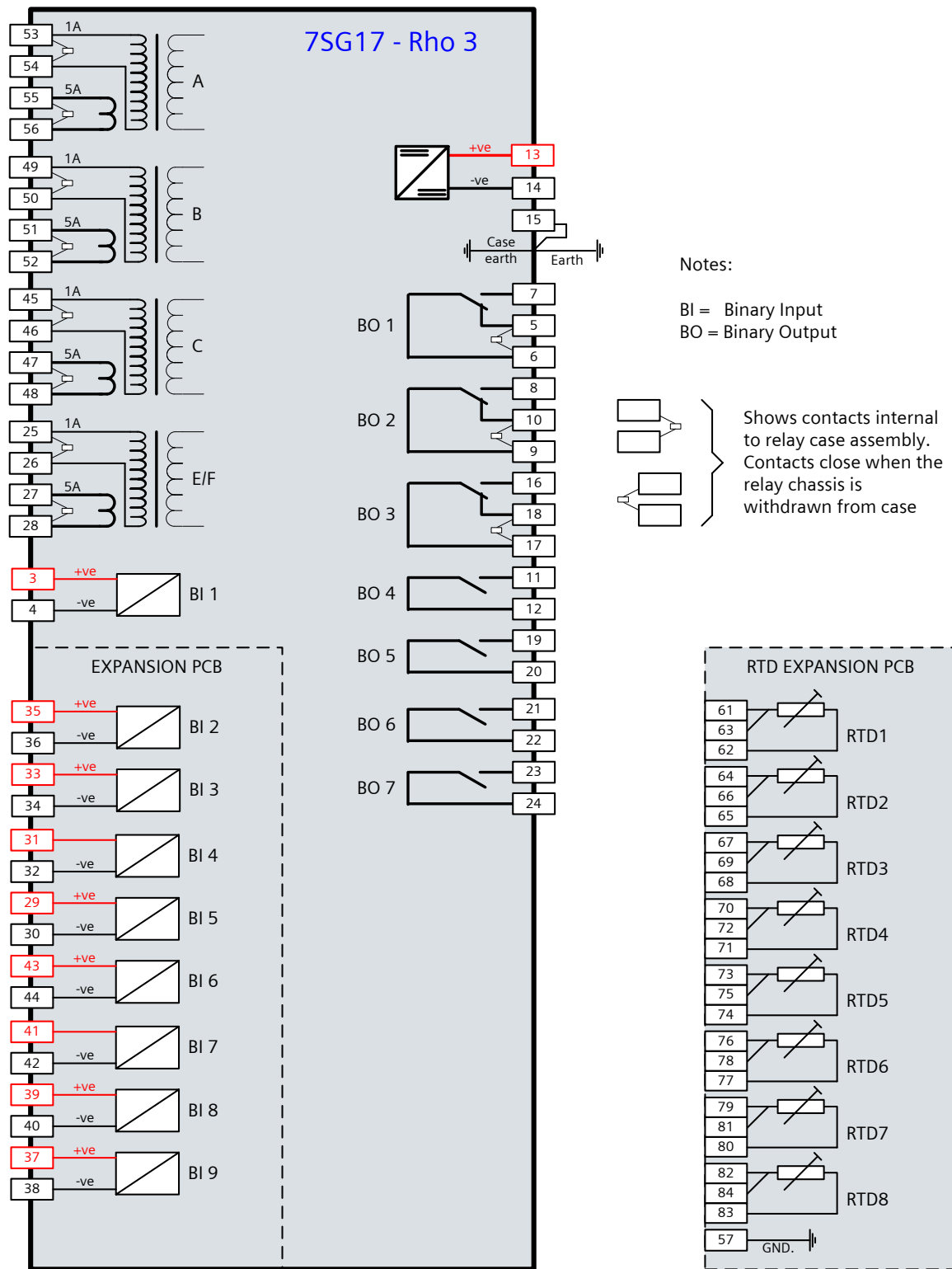

Fig 3. Connection Diagram for 7SG17 Relay

# Ordering Information – 7SG17 Rho 3

Product description	Variants	Order No.
<b>RHO 3</b>		<b>7 S G 1 7</b> <input type="checkbox"/> <input type="checkbox"/> - <input type="checkbox"/> <input type="checkbox"/> <input type="checkbox"/> <input type="checkbox"/> - <input type="checkbox"/> <input type="checkbox"/> <b>A 0</b>
HV motor & thermal protection.		↑ ↑ ↑ ↑ ↑ ↑ ↑ ↑
	<u>Relay type</u> Motor Protection Thermal Protection	1 2
	<u>Number of elements</u> Four pole relay	4
	<u>Auxiliary supply /binary input voltage</u>	
	24/30/48 V DC auxiliary, 30 V binary input	0
	110/220 V DC auxiliary, 30 V binary input	1
	24/30/48 V DC auxiliary, 48 V binary input	2
	110/220 V DC auxiliary, 48 V binary input 1)	3
	110/220 V DC auxiliary, 110 V low burden binary input	4
	110/220 V DC auxiliary, 220 V low burden binary input	5
	<u>Type of elements (Type of voltage relay)</u>	
	3 pole phase-fault and earth-fault	E
	<u>Nominal current inputs</u> 1/ 5 A	A
	<u>I/O range</u> 1 Binary Input / 7 Binary Outputs 9 Binary Inputs / 7 Binary Outputs	0 2
	<u>Communication interface</u> Fibre optic (ST-connector) / IEC 60870-5-103 or Modbus RTU RS485 interface / IEC 60870-5-103 or Modbus RTU	1 2
	<u>RTD inputs</u> No RTD inputs RTD inputs	0 D 1 E
	<u>Housing size</u> Case size E6 (4U high) Case size E8 (4U high)	D E

1) High burden 110V & 220V binary inputs compliant with ESI48-4 ESI 1 available via external dropper resistors with 48V binary input version  
 for 1 binary input and 110 V application, order resistor box VCE:2512H10066 in addition  
 for 9 binary inputs and 110 V application, order resistor box VCE:2512H10064 in addition  
 for 1 binary input and 220 V application, order resistor box VCE:2512H10068 in addition  
 for 9 binary inputs and 220 V application, order two resistor boxes VCE:2512H10067 in addition

Refer to website for application note about ESI48-4 compliance

