

RAILWAY GROUND FAULT PROTECTION DEVICES

PDR-Series



The PDR is an equipment ground fault protection device that combines hydraulic/magnetic circuit breaker and overload and short circuit protection and ground fault protection. This breaker senses and guards against faults to ground using a state of the art integrated circuit. This technology detects faults and when a fault occurs, the breaker trips and an LED illuminates. The LED gives a clear indication that the trip occurred as a result of leakage. This protection helps prevent serious equipment damage and fire.

Our Circuit Breakers are designed according to railway regulations:

- IEC 60077 - 1/2/3
- NF F62-001 - 1/2/3
- EN 45545-2 & NF F16-101/102
(fire and toxic regulations)

General technical specifications - PDR-Series

Electrical

Maximum Voltage	AC, 480 WYE/277 VAC, 50/60 Hz
Current Ratings	1.00, 2.50, 5.00, 7.50, 10.0, 15.0, 20.0, 25.0, 30.0, 35.0, 40.0 & 50.0 amps. For other ratings, consult factory.
Insulation Resistance	Minimum: 100 Megohms at 500 VDC
Dielectric Strength	1960 VAC, 60 Hz for one minute between all electrically isolated terminals.
Resistance, Impedance	from Line to Load Terminal (Values Based on Series Trip Circuit Breaker)

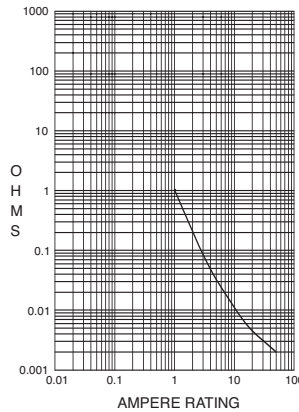

CURRENT (AMPS)	TOLERANCE (%)
0.10 - 5.0	± 15%
5.1 - 20.0	± 25%
20.1 - 50.0	± 35%

Leakage to ground

Standard Must Trip Leakage Current Ratings	7, 10, 15, 30, 50 & 100 milliamps. For other ratings, consult factory.
Trip Time	300 ms Max. @ 100%, 40ms Max. @ 500% of must trip leakage current.
Test Button	On breaker face above actuator.
Leakage Trip Indicator	Red LED on breaker face above actuator.

Mechanical

Endurance	10,000 ON-OFF operations @ 6 per minute; with rated Current & Voltage.
Trip Free	All PDR equipment leakage circuit breakers will trip on overload or leakage to ground, even when actuator is forcibly held in the ON position.

Physical

Number of Poles	2, 3 & 4 Poles
Length	106.7 mm (4.2 inches) <i>(included switched or unswitched neutral)</i>
Width	2-pole: 76.2 mm (3.0 inches) 3-pole: 95.3 mm (3.75 inches) 4-pole: 114.3 mm (4.5 inches)
Depth	63.5mm (2.5 inches)
Weight	2-pole: 453.6 g (16.0 oz.) 3-pole: 606.7 g (21.4 oz.) 4-pole: 762.6 g (26.9 oz.)
Standard Colors	Housing - gray; Actuator - black, red, or white
Mounting	Front Panel or Standard 35mm Symmetrical DIN Rail (35 x 7.5 or 35 x 15mm per DIN EN5002).
Termination	Box Lug

Environmental

Operating Temperature	-10° C to +50° C
-----------------------	------------------

Ordering Scheme - PDR-Series

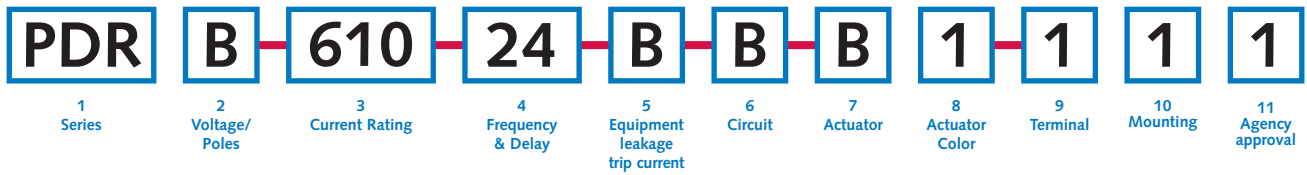

1 SERIES
PDR

2 SYSTEM VOLTAGE/POLES¹

	System Voltage	Poles
A	120VAC 1Ø	One plus unswitched neutral
B	120/240 VAC 1Ø	Two
C	120/208 VAC 1Ø, 120/240 VAC 1Ø	Two plus unswitched neutral
D	120/208 VAC 1Ø, 120/240 VAC 1Ø	Two plus switched neutral
E	208/240 VAC 3Ø	Three
F	208/240 VAC 3Ø	Three plus unswitched neutral
G	208/240 VAC 3Ø	Three plus switched neutral
P	480Y VAC 3Ø	Three
Q	480Y VAC 3Ø	Three plus unswitched neutral
R	480Y VAC 3Ø	Three plus switched neutral

3 CURRENT RATING (AMPERES)

410	1.000	445	4.500	610	10.000	717	17.500
512	1.250	450	5.000	710	10.500	618	18.000
415	1.500	455	5.500	611	11.000	619	19.000
517	1.750	460	6.000	711	11.500	620	20.000
420	2.000	465	6.500	612	12.000	622	22.000
522	2.250	470	7.000	712	12.500	624	24.000
425	2.500	475	7.500	613	13.000	625	25.000
527	2.750	480	8.000	614	14.000	630	30.000
430	3.000	485	8.500	615	15.000	635	35.000
435	3.500	490	9.000	616	16.000	640	40.000
440	4.000	495	9.500	617	17.000	650	50.000

* Other values on request

4 FREQUENCY & DELAY

20	50/60Hz Instantaneous	24	50/60Hz Medium
22	50/60Hz Short	26	50/60Hz Long

5 EQUIPMENT LEAKAGE - TRIP CURRENT (milliamps)²

B	7	D	15	F	50
C	10	E	30	G	100

6 CIRCUIT
B Series Trip (Current)

7 ACTUATOR
A Handle
B Handle with handleguard

8 ACTUATOR COLOR & LEGEND

Actuator Color	Marking			Marking Color
	I-O	ON-OFF	Dual	
White	A	B	1	Black
Black	C	D	2	White
Red	E	F	3	White

9 TERMINAL
1 Front Connected Box Lug with Pressure Plate

10 MOUNTING³
1 Threaded Insert 6-32 x 0.195 inches
2 Threaded Insert ISO M3 x 6.5 mm

11 AGENCY APPROVALS⁵
1 UL-Recognized, CSA, TUV to EN60077 and NF F62-001

- Notes:
- 1 Units with a switched or unswitched neutral connection are the same size as a unit with an additional breaker pole (e.g. a 2-pole unit with a switched or unswitched neutral is the same physical size as a 3-pole unit). Switched neutral poles contain the same overcurrent protection as the other poles.
 - 2 The leakage currents shown will cause the breaker to trip (must-trip current). The must-hold current is 67% of the must-trip current.
 - 3 All breakers are front panel mountable using screw size shown. Breakers may also be mounted on either 35mm x 7.5mm or 35mm x 15mm symmetrical DIN rail.
 - 5 Preliminary test results showed that the breakers comply to the EN60077 and NF F62-001. Certificates for UL-Recognized and CSA are available on request. For the EN60077 and NF F62-001 the certificates will be available in short notice

Time Delay Values - PDR-Series

TRIP TIME (SECONDS)	PERCENT OF RATED CURRENT										
	DELAY	100%	125%	135%	150%	200%	400%	600%	800%	1000%	1200%
20	No Trip	May Trip	---	.040 MAX	.035 MAX	.030 MAX	.025 MAX	.020 MAX	.017 MAX	.015 MAX	
22	No Trip	.700 - 12.0	---	.350 - 4.00	.130 - 1.30	.027 - .220	.008 - .130	.004 - .090	.004 - .045	.004 - .040	
24	No Trip	10.0 - 160	---	6.00 - 60.0	2.20 - 20.0	.300 - 3.00	.050 - 1.30	.007 - .500	.005 - .060	.005 - .040	
26	No Trip	50.0 - 700	---	32.0 - 350	10.0 - 90.0	1.50 - 15.0	.500 - 7.00	.020 - 3.00	.006 - 2.00	.005 - 1.00	

NOTES:
 Delay Curves 22,24,26: Breakers to hold 100% and must trip at 125% of rated current and greater within the time limit shown in this curve.
 Delay Curves 20: Breakers to hold 100% and must trip at 150% of rated current and greater within the time limit shown in this curve.
 All Curves: Curve data shown represents breaker response at ambient temperature of 25°C (77°F) with no preloading. Breakers are mounted in standard wall-mount position.
 On 50 amp and less current ratings, the minimum inrush pulse tolerance handling capability is 12 times the rated current on standard delays and 25 times the rated current on high inrush delays. These values are based on a 60 Hz 1/2 cycle, 8.33 ms pulse. High inrush delays should be specified for applications with high initial surge currents of short duration such as switching power supplies, highly capacitive loads and transformer loads.

AC

Instantaneous

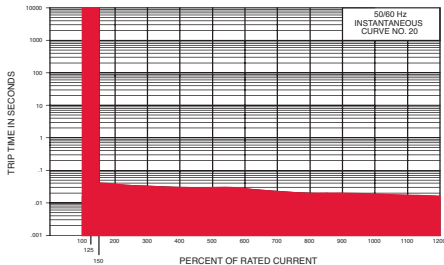

Short

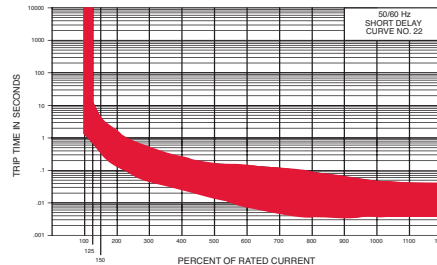

Medium

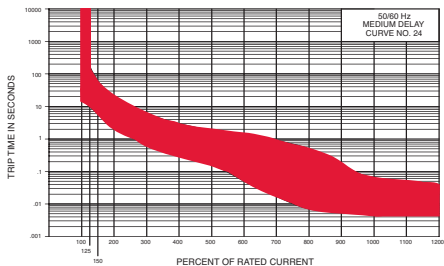

Long

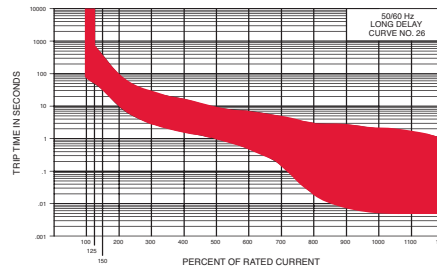

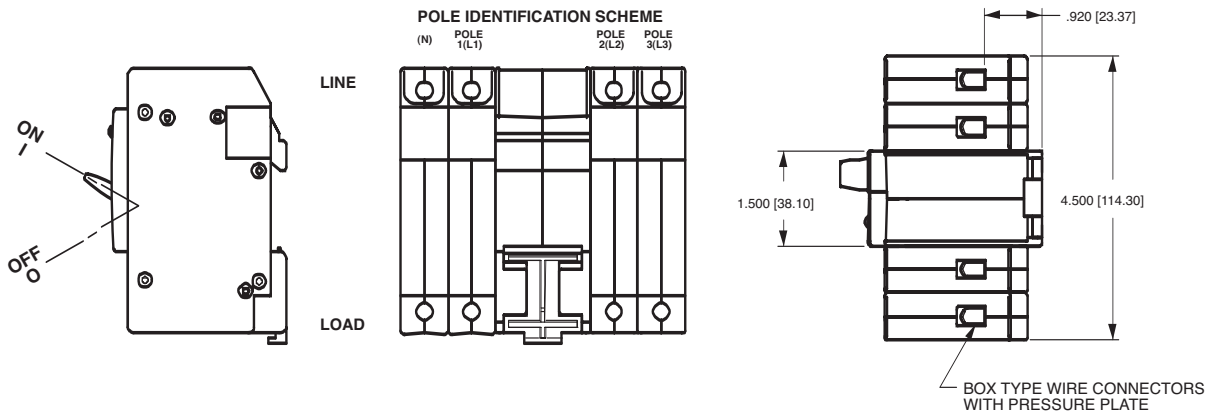
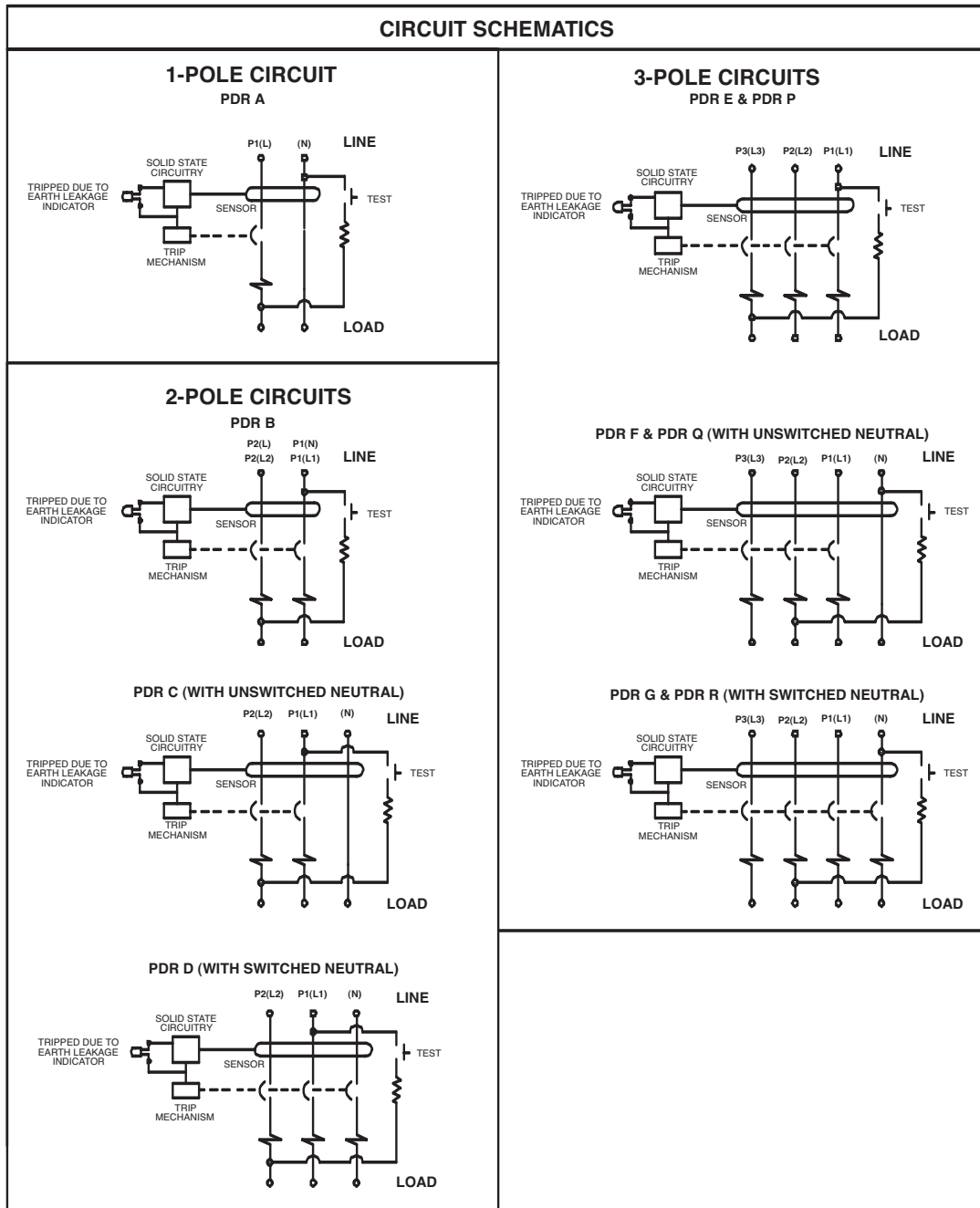

All dimensions in inches and [mm]

PDR A & PDR B

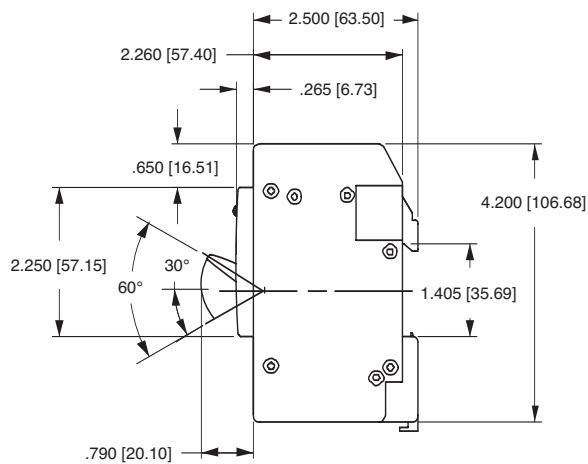
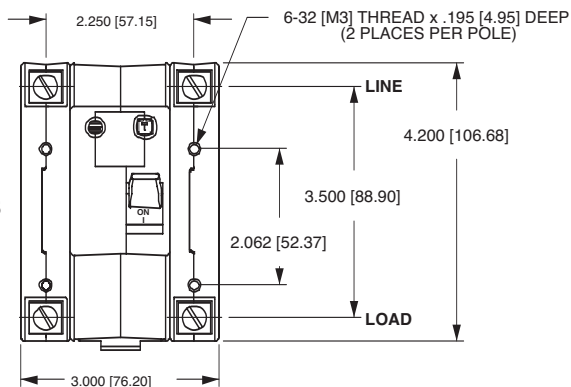

PDR C & PDR D

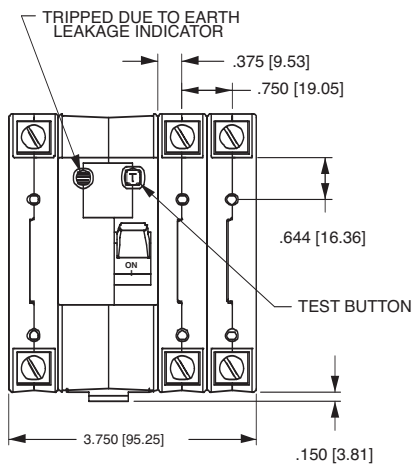

PDR E & PDR P

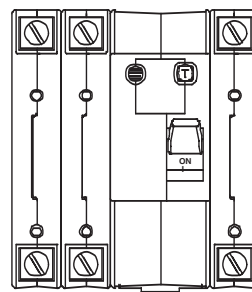

PDR F, PDR G
PDR Q & PDR R

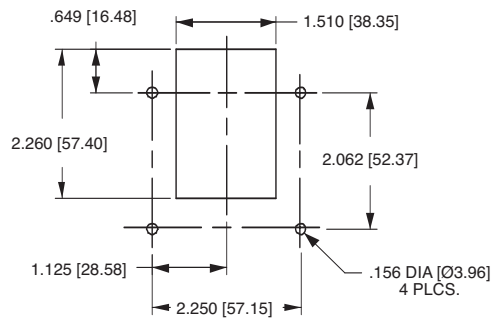
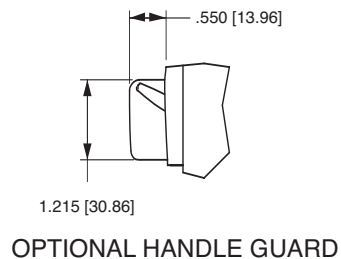
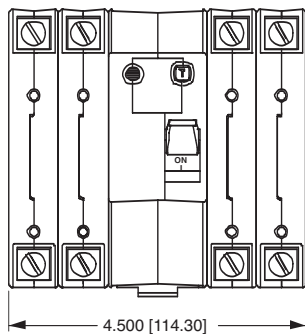

PANEL CUT-OUT DETAIL

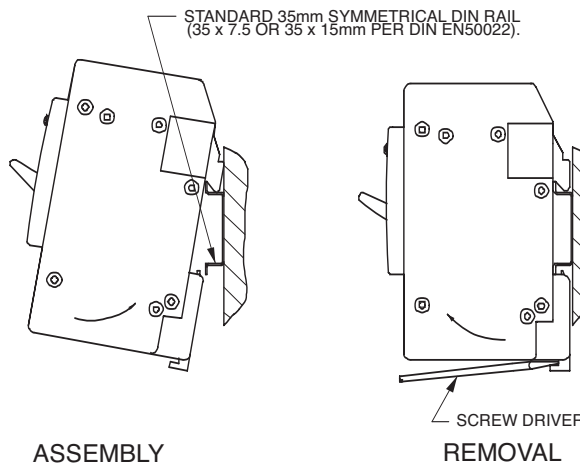

All dimensions in inches and [mm]

MORE INFORMATION?

Fill in the details below and return this fax to:



The Netherlands: +31 (0)30 289 88 16

France: +31 (0)1 48 55 90 01

USA: +1 (0)631 271 8898

Company:

Contact person: Function:

Address:

ZIP-code: Place:

Telephone number: Fax number:

Email:

Please send more information for:

- Relays** (instantaneous relays, measuring and monitoring relays and electronic time delay relays)
- Circuit protection** (hydraulic/magnetic circuit breakers, hydraulic/magnetic ground fault breakers and hydraulic/magnetic remote operated breakers)
- High voltage and current protection relays** (overcurrent, undercurrent, differential current, overvoltage, undervoltage, differential voltage and frequency measuring & monitoring relays)
- Electrical control solutions** (Form, fit and function electrical control units for retrofit/refurbishment applications and new built applications)
- Panel indicators** (analogue indicators for speed, voltage, current, power etc.)

Call for an appointment

Please add me to the mailing list

Please remove me from the mailing list



Your local distributor:

For further information please contact:

France

MS RELAIS SAS

Tour Rosny 2
Avenue du Général de Gaulle
F - 93118 Rosny-sous-Bois Cedex
France
Tel. +33 (0)1 48 12 14 40
Fax +33 (0)1 48 55 90 01
sales@morssmittrelais.com

<http://www.morssmittrelais.com>

USA

MORS SMITT TECHNOLOGIES INC.

50 North New York Avenue
Huntington, NY, 11743
USA
Tel. +1 (631) 271-8858
Fax +1 (631) 271-8898
mstechnologies@morssmittrelais.com

<http://www.morssmittrelais.com>

The Netherlands

NIEAF-SMITT BV

Vrieslantlaan 6
NL - 3526 AA, Utrecht
The Netherlands
Tel. +31 (0)30 288 13 11
Fax +31 (0)30 289 88 16
sales@nieaf-smitt.nl

<http://www.nieaf-smitt.nl/railway>

Proven Reliability

Australian Distributor



Relay Monitoring Systems Pty Ltd
6 Anzed Court
Mulgrave, Victoria, 3170, Australia

Phone: +61 3 8544 1200
Fax: +61 3 8544 1201
Email: rms@rmspl.com.au
Web: www.rmspl.com.au