

# 1B230

Fact Sheet

1B230

## Single or Double Shot Auto Reclose Relay

### Features

- Single or double shot reclose with selectable auto reset mode
- Shunt initiate input
- Optional series initiate input
- Safe to reclose input
- Line voltage interlock
- CB reclose spring status input to defer auto reclose pulse until fully charged
- Lockout LED indication
- Drive to lockout input
- Remote reset input
- Reclose in progress LED
- Instantaneous protection inhibit output & LED indication
- Wide auxiliary supply range with fail alarm contact
- Independently adjustable dead time delay per shot
- Common adjustable reclaim time delay
- Optional reclose counter
- Simple rugged design
- Size 4M draw out case

### Application

Operating records for overhead power lines reveal that most faults are of a transient nature (e.g. lightning induced) & that service interruptions may be minimized by use of automatic reclosing of circuit breakers.

An automatic reclosure of the circuit breaker, after the fault clears, provides improved service continuity & system stability.

The 1B230 Series Reclose Relay provides for single or double shot automatic reclosing of circuit breakers, following interruption of supply due to a fault in the system.



1B230 depicted in a 4M28 case

### Operation

The 1B230 auto reclose relay provides up to two shot auto reclose control for distribution and transmission systems. Dead times for both shots (reclose attempts) are independently adjustable.

An auto reclose cycle is initiated by operation of a protective relay (INP Main Protn), provided the circuit breaker is closed until the instant of protection operation.

Dead time 1 or 2 start when the circuit breaker has tripped (INP CB Aux Switch) and the protection has reset.

At the end of the dead time, a CB close signal is given (output RLY CB Close Sig), provided input signals are present indicating that system conditions are suitable (INP Safe To Close), and the circuit breaker closing spring, or other energy source, is fully charged (INP Spring Charge).

The safe to close signal is taken from a contact on a separate voltage monitor or synchronism check relay, and the spring charged signal is taken from an auxiliary switch contact on the circuit breaker. The CB close signal is cut off when the circuit breaker closes.

Once the output pulse to close the circuit breaker is completed, the reclaim time starts. If the circuit breaker remains closed until the reclaim timer times out, the 1B230 resets if in auto mode or goes to lockout.

However if the protection operates again & the circuit breaker trips before the reclaim time has elapsed, the 1B230 either advances to the next shot in the programmed auto reclose cycle, or, if all programmed reclose attempts have been made, goes to lockout.

# 1B230

## Function Details

### BLOCK INSTANTANEOUS TRIPS OUTPUT

A Block Instantaneous Trips output (**RLY Block Inst Pr**) can be arranged to block the trip function of non-discriminating protection, such as low set instantaneous overcurrent or earth fault protection, or distance protection operating with Zone 1 extension. This function is used to ensure that the final trip to lock out for a persistent fault is made by discriminating protection & can be set at the front panel to operate after the first trip, after the second trip or to OFF (Function disabled).

The output relay is normally reset and to operates (contact closes) to block non-discriminating protection.

This is suitable for most modern protective relays such as Ohmega & Argus.

### CIRCUIT BREAKER AUXILIARY CONTACT

An auxiliary contact on the circuit breaker (Closed when the CB is tripped) is required to monitor the operation of the CB using the **INP CB Aux Switch**.

### LINE VOLTAGE INTERLOCK INPUT

Line status information is derived from input **INP Line Volt Mon**. This feature inserts additional checks in the auto reclose initiation and dead time start logic, such that an auto reclose cycle can only be initiated if the line was live until immediately before the protective relay operation, and the dead time cannot start until the line has gone dead.

Front panel switch selection of Live Line IN or OUT.

### CB RECLOSE SPRING STATUS INPUT

Application of a control voltage to the **INP Spring Charge** input will defer the CB reclose output pulse (**RLY CB Close Sig**) until the signal is removed. This function is used to ensure that the CB will not receive a reclose pulse until after the reclose spring is fully charged.

The spring charged signal is taken from an auxiliary switch contact on the circuit breaker.

If the **INP Spring Charge** input defers the CB reclose output pulse for 60s the 1B230 will go to lockout.

### MAIN PROTECTION INTERFACE

Two input types are provided to interface with the main protection to initiate the reclose cycle:

- Shunt initiate Voltage input to **INP Main Protn Shunt**  
Pulse Length >40 m Sec
- Series initiate Current input to **INP Main Protn Series**  
(optional) Current >1.2 Amp DC  
Pulse Length >40 m Sec  
Resistance <0.05 Ohm

### SAFE TO CLOSE INPUT

A control voltage to the **INP Safe To Close** input must be applied before a CB close pulse can be output.

If the CB reclose output pulse is delayed for 60s by the **INP Safe to Close** input is not being applied, the 1B230 will go to lockout.

### DRIVE TO LOCKOUT INPUT

Application of a voltage pulse to the **INP Drive To Lockout** input will drive the 1B230 to the lockout condition.

### RESET RELAY FROM LOCKOUT

The 1B230 may be reset from the lockout condition in 3 ways:

- Application of a voltage pulse to the **INP Reset Lockout** input;
- Pressing the front panel reset button;
- Interruption of the auxiliary supply for >10s.

### RECLOSE OPERATION

Front panel switch selection of Single (1) or double Shot (2)  
Front panel switch selection of Lockout (L) or Auto Reset (A)  
The contact closure output pulse (**RLY CB Close Sig**) is of 2 second duration.

### TIME DELAY SETTING RANGES

Dead Time 1 (Reclose 1): 5 to 180s  
Dead Time 2 (Reclose 1): 5 to 180s  
Reclaim Time Delay: 5 to 60s

### TIMING ACCURACY

Repeat  $\pm 1\%$  of setting  
Setting  $\pm 2\%$  of max. setting

### OPERATION INDICATORS

LED indication of relay healthy  
LED indication of reclose in progress - Initiation to reset or lockout  
LED indication of block non discriminating protection  
LED indication of relay in lockout condition

### OPTIONAL COUNTER (Cumulative)

7 Digit (non reset).

### STATUS INPUT SUMMARY

Description	Signal	Comments
INP CB Aux Switch	Steady state	Apply volts
INP Main Protn Shunt	Pulse	Apply volts
INP Main Protn Series	Pulse	Apply current (Optional)
INP Safe To Close	Steady state	Apply volts
INP Spring Charge	Steady state	Apply volts
INP Drive To Lockout	Pulse	Apply volts
INP Reset Lockout	Pulse	Apply volts
INP Line Volt Mon	Steady State	Use Live Line In switch

### RELAY OUTPUT SUMMARY

Description	Signal	Comments
RLY A/R In Prog	Steady state	1 C/O follows LED
RLY CB Close Sig 1	2s pulse	1 C/O
RLY CB Close Sig 2	2s pulse	1 C/O
RLY Block Inst Pr	Steady state	1 C/O
RLY A/R Lockout	Steady state	1 C/O
RLY Fail alarm	Steady state	1 C/O P/U when healthy

# 1B230

## AUXILIARY SUPPLY BURDEN (At 110V DC)

Less than 5W independent of range with output relays picked up.

## AUXILIARY SUPPLY

20-70V AC/DC switchmode supply or  
40-275V AC / 40-300V DC switchmode supply  
Burden: Less than 7 watts during timing

### Inputs:

A high efficiency switchmode power supply is incorporated which provides a low burden to the auxiliary supply and operates over the range 75 to 140V AC & 70 to 150V DC.

### Input Transients:

Withstands multiple high energy transients & ring waves in accordance with IEEE28 - ANSI C26.1 Cat. II, accordingly:

- 0.5uS 100KHz      6KV O/C, 500A S/C, 4J
- 1.2/50uS          6Kv O/C
- 8/20uS             3KA S/C, 80J clamped at 1,000V

Mains conducted EMI within limits specified by AS 3548 Class B.

### Isolation:

The inputs are isolated from the outputs in accordance with AS 3260 Class II Limited Current Circuitry, accordingly:

- Withstand voltage of 2.5Kv RMS 50Hz for one minute
- Creepage & clearance distance greater than 4mm
- Output leakage current less than 0.25A to earth

### Power Supply Alarm Relay:

A normally closed contact rated at 10A 250V AC & isolated as per AS 3260 is energized when both the auxiliary supply & internal 24V DC rail is within acceptable limits. The relay faulty alarm output will be set if the incoming supply or switch mode circuit fails.

### Output Protection:

Outputs will withstand continuous short circuit. Output regulators & switching control regulator are thermally protected.

## SCHRACK OUTPUT CONTACT RATINGS

### Make & carry

30A AC or DC (Limits L/R=40ms & 300V max.) for 0.2s  
20A AC or DC (Limits L/R=40ms & 300V max.) for 0.5s  
5A AC or DC continuously

### Break (Limits 5A & 300V max.)

1,250VA AC resistive  
250VA at 0.4PF AC inductive  
75W DC resistive  
30W DC inductive L/R = 40ms  
50W DC inductive L/R = 10ms

### Minimum recommended load

0.5W, 10mA or 5V minimum.

## Relay Ratings

### AMBIENT OPERATING TEMPERATURE RANGE

-5 to 55 degrees C.

### NOISE IMMUNITY

Withstands the high frequency interference test detailed in IEC 255-22-1.

### INSULATION WITHSTAND in accordance with IEC 255-5:

2KV RMS & 1.2/50 5KV impulse between:

- ◆ all input terminals & frame
- ◆ all output terminals & frame
- ◆ all input & output terminals
- ◆ each input group
- ◆ each output group

Across open contacts: 1KV RMS

### ELECTROSTATIC DISCHARGE

EN61000-4-2:1995 8KV Level 3

### RADIO FREQUENCY INTERFERENCE

EN61000-4-3:1995 10V/m Level 3

### FAST TRANSIENT DISTURBANCE

EN61000-4-4:1995 4KV Level 4

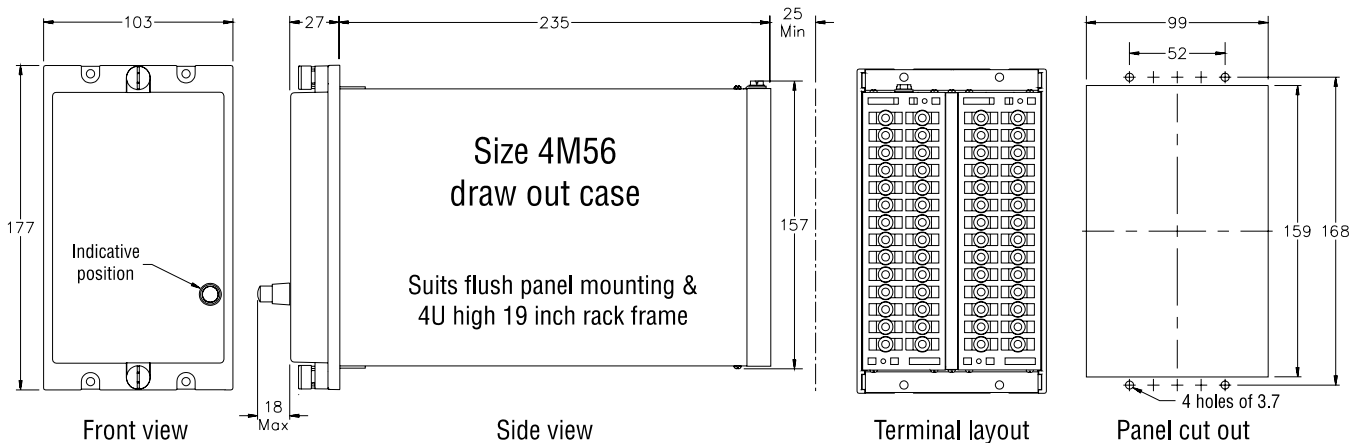

# 1B230

## Terminals & Wiring

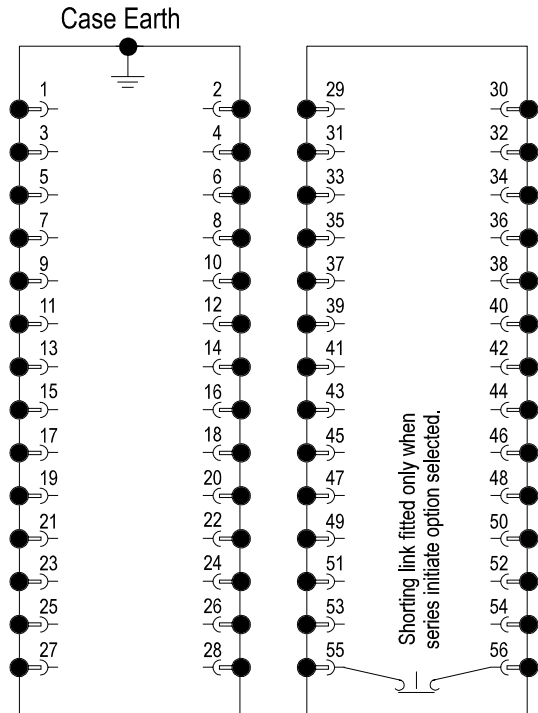

4M56 Case terminations (REAR VIEW)

### CASE

Size 4 draw out  
 56 M4 screw terminals  
 Flush panel mount or 4U high 1/4 width 19 inch rack mount  
 IP51 rating

### ACCESSORIES SUPPLIED WITH EACH RELAY

1 x M4 self threading mounting screw kit P/N 290-406-151  
 2 x M4 terminal screw kit (28 per kit) P/N 290-407-153  
 1 x Product Test Manual

### SHIPPING DETAILS

Each relay is supplied individually packed in pre formed cardboard cartons with internal moulded polystyrene former.

Weight: 3Kg

Size: 370(L) x 240(W) x 145(D)mm - Size 4 case

For large shipment individual cartons are packed in sturdy cardboard pallet boxes & surrounded by loose fill to absorb vibration & shock during transit.

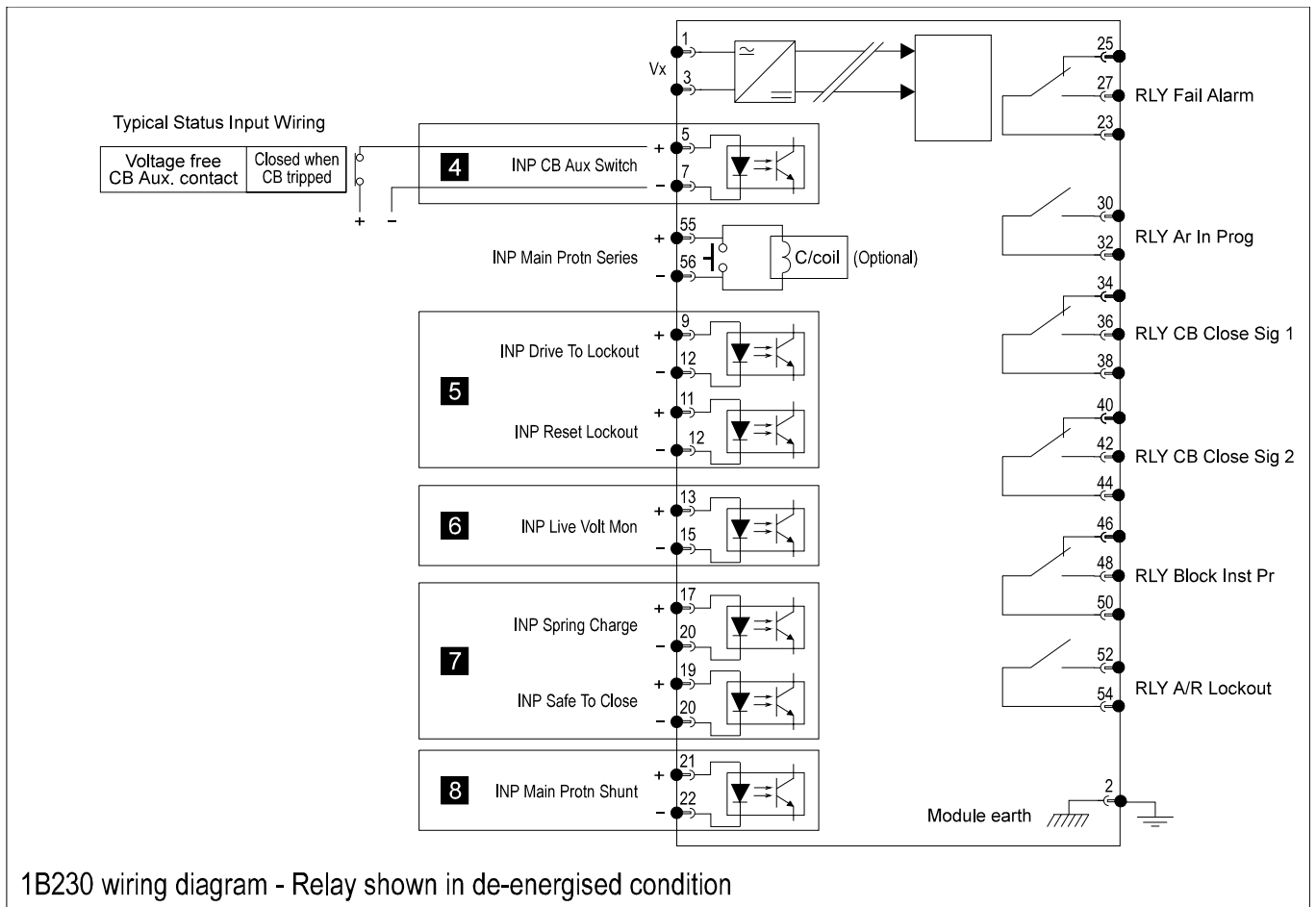

1B230 wiring diagram - Relay shown in de-energised condition

### 1B230 TYPICAL AUTO RECLOSE TIMING SEQUENCE

Two shot sequence;  
 INP Safe To Close used;  
 INP Spring Charge used;  
 Inhibit instantaneous protection after 2nd CB trip;  
 Live Line ON;  
 AUTO reset.

