

Features

- Compact & rugged construction
- Fully insulated module
- Suitable for high impedance differential BUS protection schemes
- Suitable for restricted earth fault REF protection schemes
- High energy absorption rating
- Pre-wired with heavy duty stud or screw terminals
- Specify 3 or 6 inch Metrosils
- Specify 1 phase or 3 phase
- Optional stabilizing resistors with convective cooling ports
- Specify nominal value of adjustable stabilizing resistors
- Specify stabilizing resistor power rating
- Rear swing door access for stabilizing resistor adjustment
- Heavy duty construction comprising aluminium side plates to ensure excellent mechanical & thermal performance

Application

The 2V75 Metrosil module is designed for application with high impedance differential protection schemes.

An external Metrosil unit having a non-linear resistance characteristic is required for each phase element to limit the peak voltage appearing across the secondary differential circuits under internal fault conditions.

The type of Metrosil characteristic required is dependant on the relay setting range. The differential protection relay application data should be consulted to determine the correct Metrosil rating.

For current operated differential protection relays (e.g. RMS 2C73), a series stabilizing resistor is employed to achieve the required voltage stability setting.

For voltage operated differential protection relays (e.g. RMS 2V73), the series stabilizing resistors are generally not required.



2V75 depicted in a size 8 rack or flush mount module

Operation

The 2V75 Module provides a compact, simple & cost effective means of fitting a pre-wired Metrosil & resistor combination into protection panels employing high impedance differential schemes.

Mounting is achieved by first fitting a special panel to the front of the cubicle. This panel is suitable for 19 inch rack or flush mounting.

The separate Metrosil module is then installed from the rear of the cubicle & latched onto the self aligning rails on the front mounting panel. Retention screws are provided to lock the Metrosil module in place.

The Metrosil module may, alternatively, be surface mounted in the rear of the cubicle.

Heavy duty screw terminals are provided on the rear of the Metrosil module to suit ring or crimp lug terminals. Internal wiring utilizes 2.5mm² cable.

The rear terminal door may be swung open to access the stabilizing resistors (where fitted) to allow adjustment.

The completed installation is compact while providing safety isolation, the desired level of ventilation for the stabilizing resistors & a means of simple adjustment.

RELATED EQUIPMENT

- ◆ Refer to the 2V73 Technical Bulletin for details on the RMS voltage operated differential / REF protection relay;
- ◆ Refer to the 2C73 Technical Bulletin for details on the RMS current operated differential / REF protection relay;
- ◆ Refer to the 1M123 & 1M124 Technical Bulletin for details on complete BUS protection rack solutions;
- ◆ Refer to the 2V68 Technical Bulletin for details on CT supervision applications;

2V75

MODULES WITH INTERNAL SHUNT WIRING

Select one of the following wiring configurations where shunt wiring is made internally.

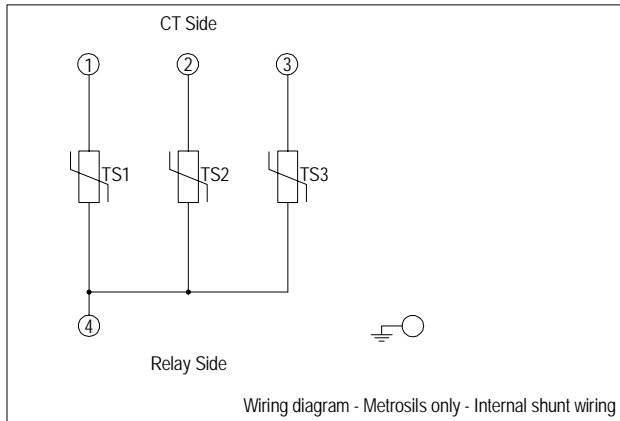
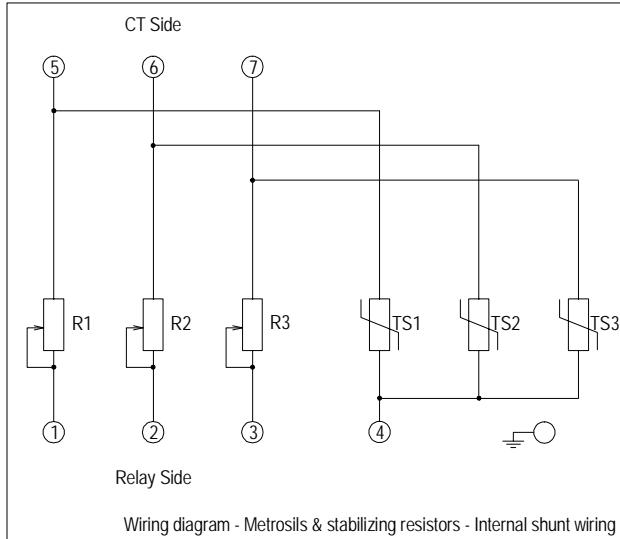

Module Configuration

MODULES SUITABLE FOR EXTERNAL SHUNT WIRING

Select one of the following wiring configurations where shunt wiring may be made externally to the module.

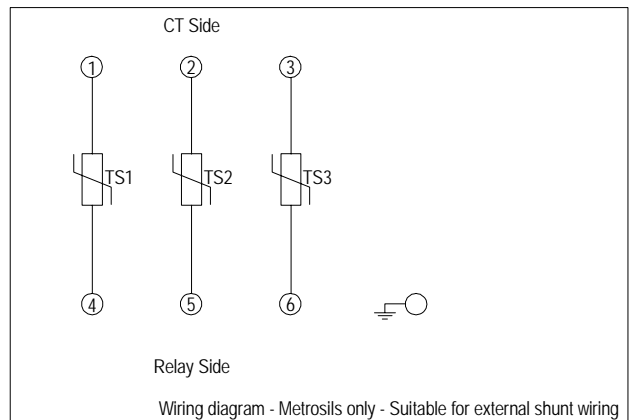
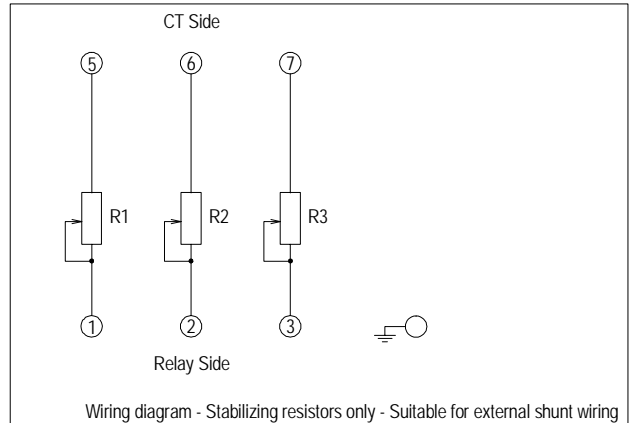
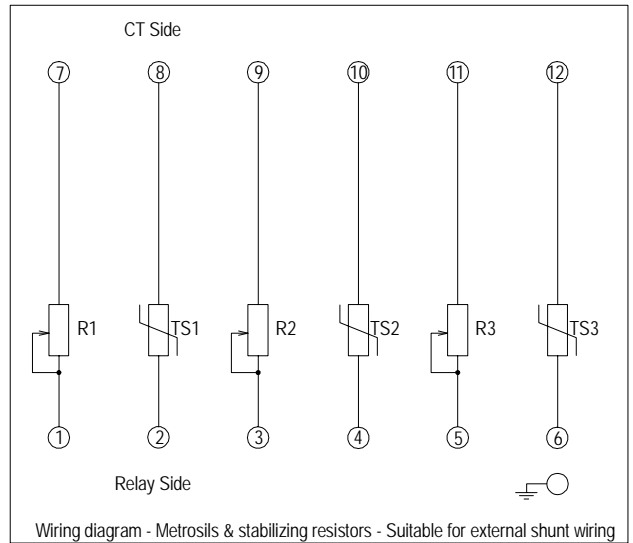

2V75

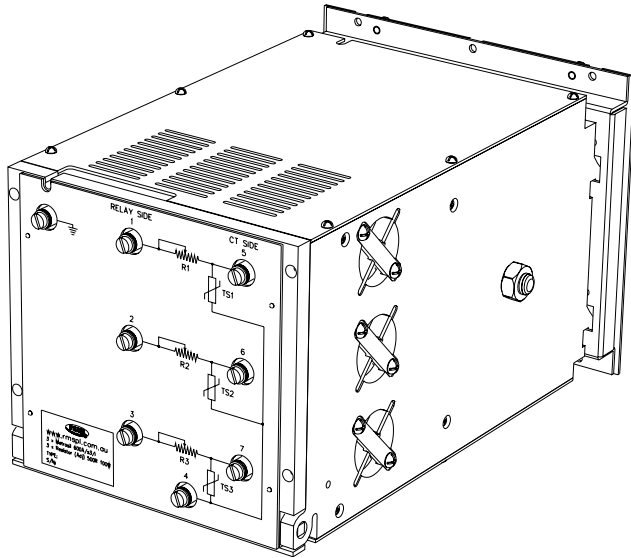

2V75 rear panel detail showing terminal wiring
(Rear terminal cover not shown)

Remove the 4 retaining pillars & swing open the rear panel to access the adjustable stabilizing resistors.

Technical Data

METROSIL SPECIFICATIONS

Refer page 3 for V-I curves.

Order code: [A]
Diameter: 152mm (6 inch)
Model: 600A / S3 / I SPEC 887
C-Value: Nominal: 1,000
Minimum: 850
Maximum: 1,150
B-Value: Nominal: 0.22
Minimum: 0.20
Maximum: 0.25
Energy absorption: 33kJ/s
Short time rating: 37A RMS/1s
15A RMS/3s
MetroSil part number: 2105C58001

Order code: [B]
Diameter: 76mm (3 inch)
Model: 300A / S3 / I SPEC 3063
C-Value: Nominal: 1,000
Minimum: 850
Maximum: 1,150
B-Value: Nominal: 0.22
Minimum: 0.20
Maximum: 0.25
Energy absorption: 8kJ/s
Short time rating: 11A RMS/1s
4A RMS/3s
MetroSil part number: 2105C58006

100W RESISTOR SPECIFICATIONS

Model: HTR100
Type: Wire wound
Resistance options: 250 Ohm (125-250 Ohm adjustable)
500 Ohm (250-500 Ohm adjustable)
1,000 Ohm (500-1,000 Ohm adjustable)
Resistor thermal rating: 100W Max. at nominal resistance setting

200W RESISTOR SPECIFICATIONS

Model: HTR200
Type: Wire wound
Resistance options: 250 Ohm (125-150 Ohm adjustable)
500 Ohm (250-500 Ohm adjustable)
1,000 Ohm (500-1,000 Ohm adjustable)
Resistor thermal rating: 200W Max. at nominal resistance setting

MODULE THERMAL RATING

100W Stabilizing resistors

The maximum short time power dissipation rating is 100W per stabilizing resistor (When set to the nominal resistance value). The 2V75 MetroSil module is rated well beyond the level required for normal protection operation & fault clearance times.

200W Stabilizing resistors

The maximum short time power dissipation rating is 200W per stabilizing resistor (When set to the nominal resistance value). The 2V75 MetroSil module is rated well beyond the level required for normal protection operation & fault clearance times.

The following V-I curves are for the standard M&I Metrosil discs available with the 2V75 module.

V - I Curve of 600A 6 Inch Metrosil Spec.887

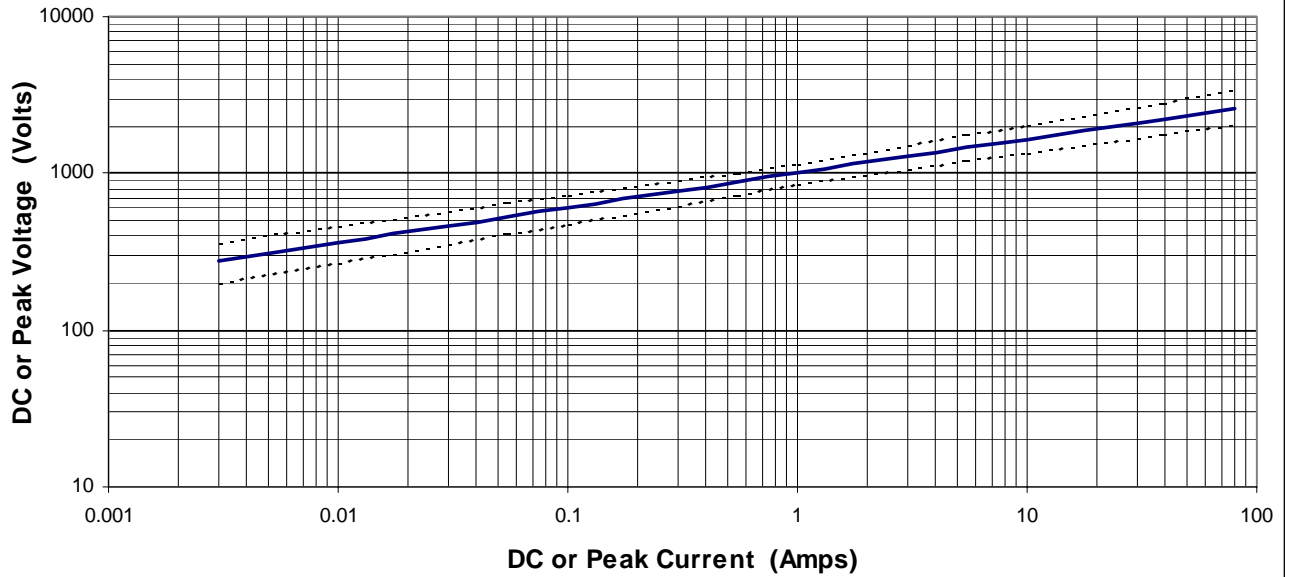

V - I Curve of 300A 3 Inch Metrosil Spec.3063

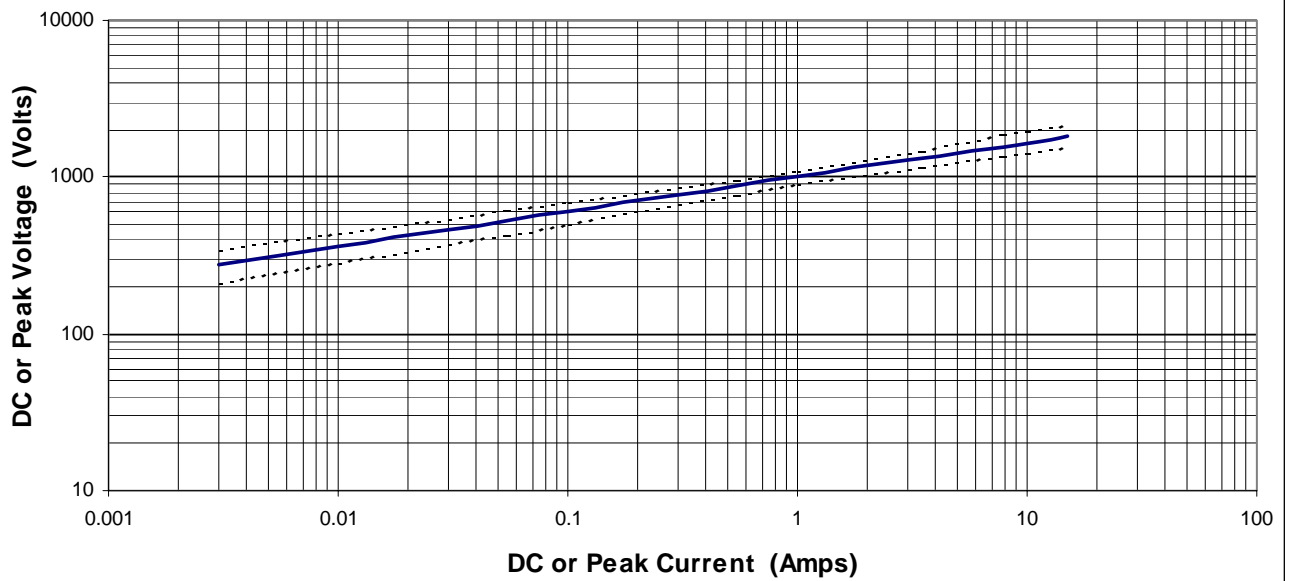

2V75

Mounting

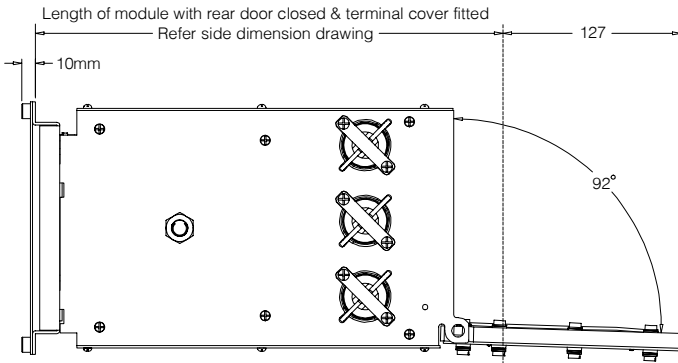

2V75 with rear open to access stabilizing resistors for adjustment

MOUNTING

Size 8, 4U 19 inch rack mounting (Half width)

or
Flush mount

or
Surface mount

When mounting other relays or equipment directly above the 2V75 module, it is recommended that a space equivalent to 1U be allowed to ensure that the air flow out of the top ventilation slots will not be impeded. Refer side view dimension drawing.

VENTILATION

Ventilation slots provided top & bottom promote convective cooling of the internal components. The wire wound ceramic resistors are securely mounted on high temperature rated aluminium spacers. The side panels are fabricated from 8mm aluminium & incorporate cooling ports at the both ends of each stabilizing resistor to allow cross ventilation.

INSULATION WITHSTAND

IEC60255-5 2KV RMS & 1.2/50 5KV impulse between all terminals & frame

Remove front label to access
Metrosil module retention screws

Internal MetroSil disk position
3" or 6" may be specified

Resistor cross
ventilation ports

Rear terminal
cover

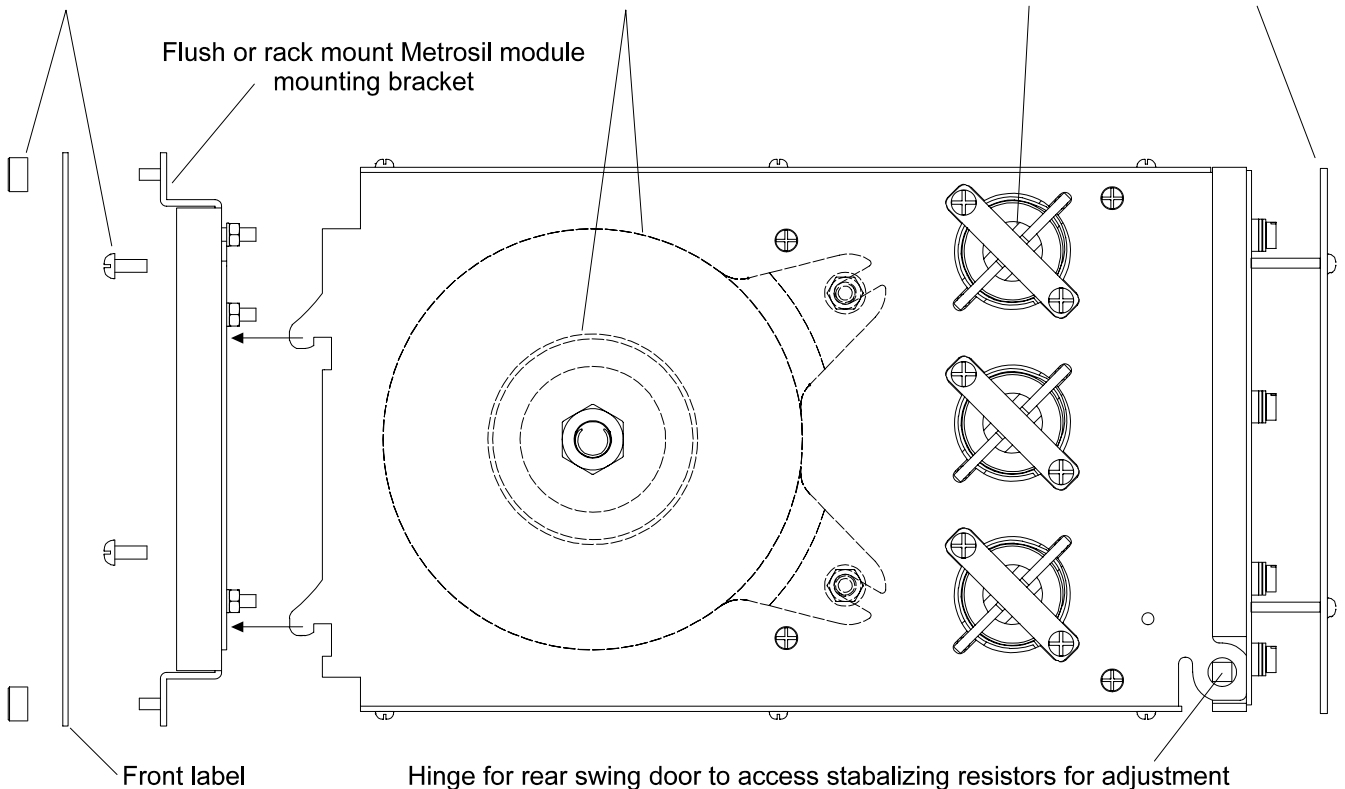

Side view showing the MetroSil module separated from the rack / flush mounting plate

2V75

2V75 Dimensions

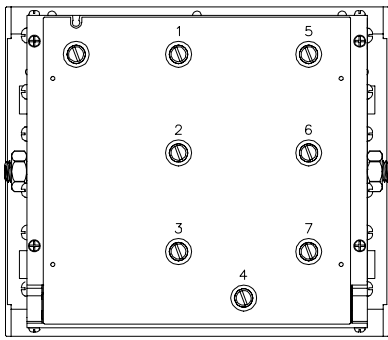

Rear view showing terminal numbers

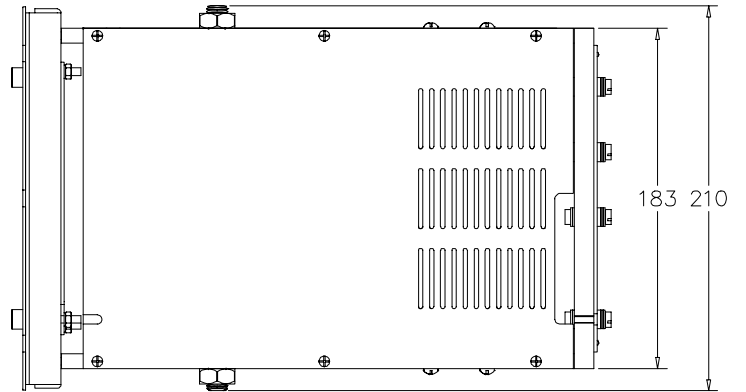

Top view showing stabilizing resistor ventilation slots (mm)

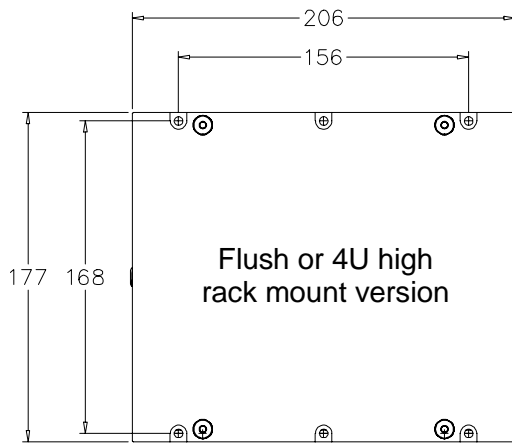

Front panel dimensions (mm)

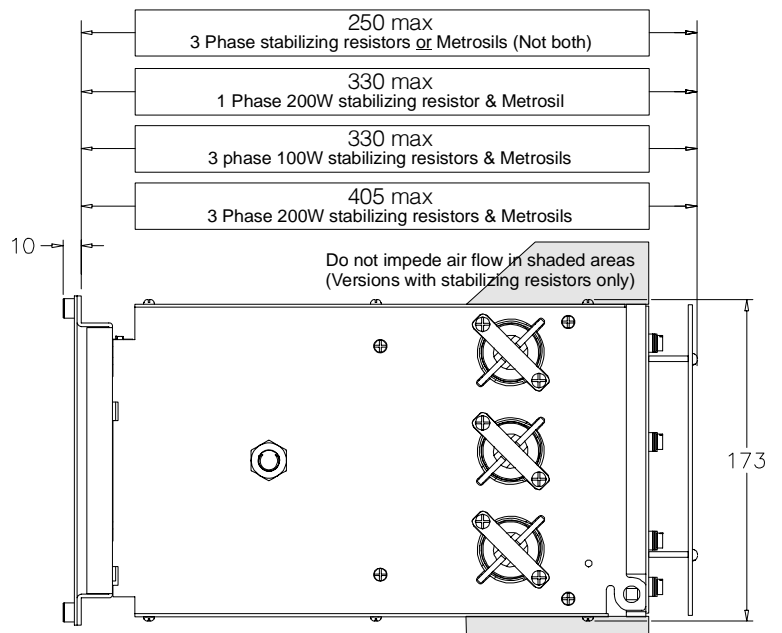

Side view dimensions (mm)

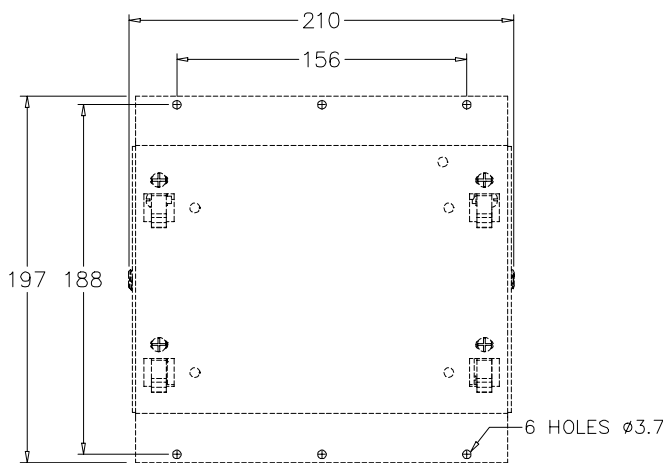

Surface mounting details (mm)

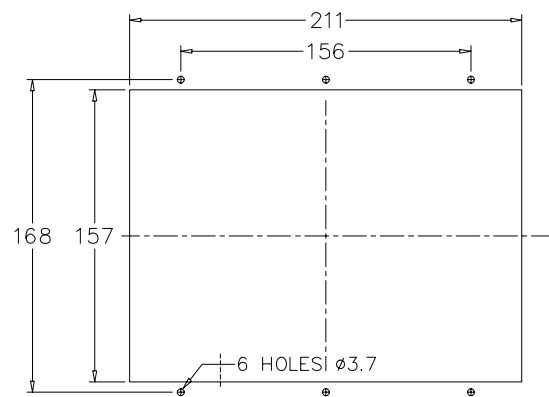

Flush mount panel cut out dimensions (mm)

2V75

Ordering Information

Generate the required ordering code as follows: e.g. 2V75-ABABBA

2V75 1 2 3 4 5 6

1 METROSIL SIZE

- A 152mm (Six inch)
- B 76mm (Three inch)
- C Not required (Resistors only fitted)

2 STABILIZING RESISTOR VALUE

- A Not required (Metrosil only fitted)
- B Required – 500 Ohms
- C Required – 1K Ohms
- D Required – 220 Ohms
- S Required – Specify value: _____ Ohm

3 MOUNTING HARDWARE

- A Rack or panel mount configuration
- B Rear cubicle surface mount (Module & bracket only)

4 STABILIZING RESISTOR POWER RATING

- A Not required (Metrosil only fitted)
- B 100W at nominal resistance
- C 200W at nominal resistance

5 NUMBER OF PHASES

- A Single phase
- B Three phase

6 SHUNT WIRING

- A Internal
- B External

Made in Australia
Relay Monitoring Systems Pty Ltd
P.O. Box 166
Huntingdale
Melbourne
Victoria 3166
Australia
Phone: +61 (3) 9561 0266
Fax: +61 (3) 9561 0277

E-mail: rms@rmspl.com.au

www.rmspl.com.au/spdl.htm

© 2010 Relay Monitoring Systems Pty Ltd

Due to RMS continuous product improvement policy this information is subject to change without notice.