

Features

- Bi-direction group intertripping of up to four (4) stations (sites)
- Operates using conventional metallic pilot wires
0 to 2K ohm pilot resistance
0 to 2uF pilot capacitance
- Inherent 5KV or 15KV isolation
No external components required
- Integrated pilot wire supervision system to identify location of pilot faults
- Extensive self supervision features to ensure tripping integrity
- Integrated trip circuit supply supervision
- Simple to set up & commission
- Flush, rack or projection mounting
- M4 screws for control wiring
- M5 studs for pilot cable connection with clear protective isolation cover (15kV version)

Application

Intertripping over copper pilots using a DC signal is commonly used where these pilots are already installed. While very reliable, traditional DC intertrip systems which provide a fully supervised two ended intertrip scheme with 15KV isolation are bulky & expensive.

The 3A300 has been designed to integrate a complete scheme allowing bi-directional group intertripping of up to four remotely connected sites. Inherent 5KV or 15KV isolation allows application on electrical networks where large induced voltages may be experienced on the pilots.

Figure 1 depicts a number of typical applications where group intertripping may be applied using the 3A300 system.

System reliability is provided by the extensive built in supervision facilities. Security is achieved through the high isolation & AC immunity of the intertrip receive elements.

The efficient compact design of the 3A300 makes it suitable for surface or panel mounting & allows the use of standard sub station batteries.



3A300 DC Supervision Station Front Panel
15KV isolation level size 8 case version depicted

Description

Each 3A300 station comprises the following functional elements:

- ◆ Intertrip send input which is interfaced to the local protection trip contact;
- ◆ Intertrip receive output contact which is interfaced to the local breaker;
- ◆ Isolated DC intertrip voltage for application to pilot wire as required;
- ◆ Pilot wire supervision system to monitor the pilot wire integrity;
- ◆ Trip voltage supply input to provide local trip circuit supply supervision;
- ◆ Self supervision circuitry to monitor & alarm in event of system failure;
- ◆ A control panel for setting & displaying the system status.

Intertripping

Intertripping is achieved by application of a DC signal onto the pilot for 2s at the send end. An intertrip can be initiated at any 3A300 station & all other 3A300 stations will respond by closing their trip receive contacts.

Pilot Wire Supervision

When activated, pilot wire supervision is based on a lower DC signal that is monitored by all stations & an alarm initiated in the event of a fault. Two modes (Continuous & pulse), may be selected.

AC Immunity

AC filtering is employed on the intertrip receive & supervision receive elements to provide immunity to AC voltages which may be induced on the pilot & otherwise cause mal operation.

Pilot Wire Isolation

5KV or 15KV power supply isolation is provided using a compact encapsulated isolating transformer utilizing triple insulated Teflon winding wire. The intertrip & pilot wire supervision send & receive channels are isolated using fibre optic links.

3A300

SYSTEM OPERATION

The 3A300 uses a DC/DC converter to generate a regulated DC intertrip voltage. This voltage is maintained on the isolated side of the circuit & is switched onto the pilot lines when an intertrip send command is applied.

A DC intertrip receive element is incorporated which will operate down to a tripping threshold of 70V DC providing adequate head room for voltage losses on the pilots & up to three other 3A300 stations on the same circuit.

When an intertrip send signal is applied to any 3A300 station, remote tripping at all other stations is effected.

Intertrip Send ●
Intertrip Receive ●

Refer to the typical applications shown in figure 2 & the functional block diagram depicted in figure 6.

PILOT WIRE CONNECTION

Connection of 2, 3 or 4 3A300 DC Intertrip stations onto a single pilot is possible. Where there is more than one slave station the master station should be located centrally.

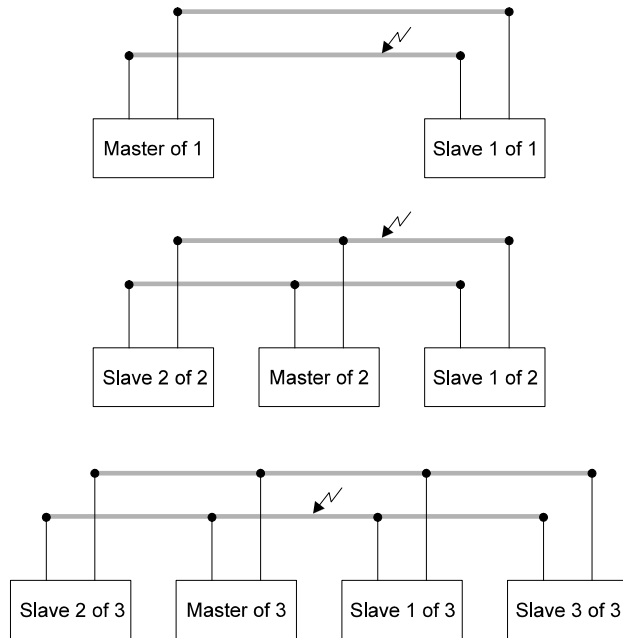

Figure 1

COMPATIBILITY WITH OTHER DC INTERTRIP SYSTEMS

It is possible to interface a 3A300 Intertrip station with existing DC intertrip receive relays. It is not possible however to utilize the integrated supervision facilities nor can the bi-directional intertripping capabilities be exploited.

Intertrip Applications

TYPICAL APPLICATIONS

Typical circuit applications are shown for 2, 3 & 4 station intertripping schemes.

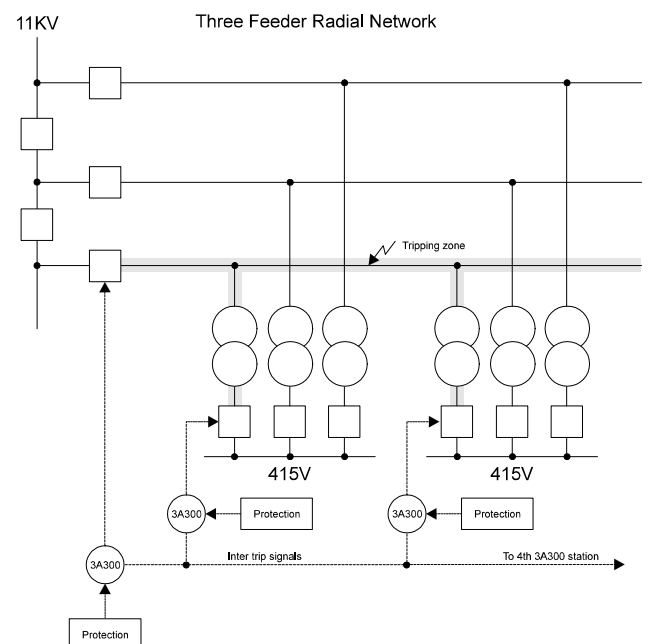
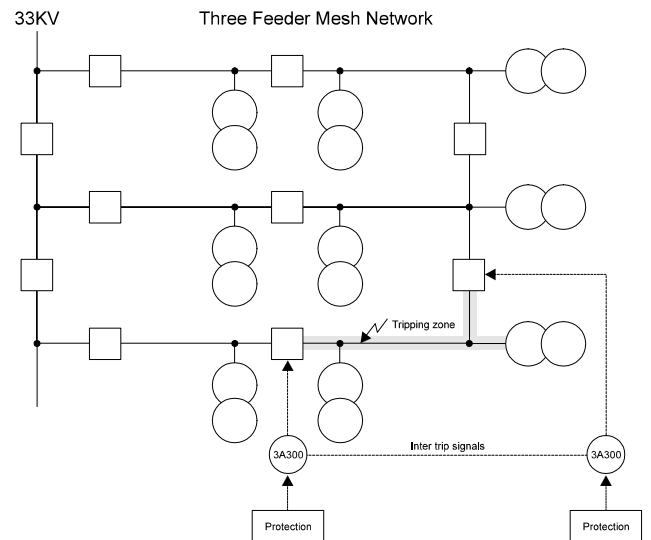
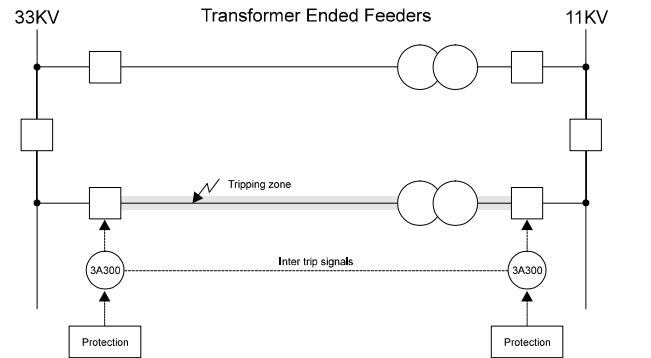

Figure 2

3A300

INTERTRIP TIMES

System intertrip times are defined as the time from application of the intertrip send signal to closure of the intertrip receive contacts at the remote station.

Intertrip send times are a combination of the series events which take place in the system when a send command is received:

1. Intertrip send signal processing

Typically 10ms. This high speed input requires a minimum operate current of 50mA at 48V DC to ensure security due to induced AC noise on the control wiring.

2. Intertrip voltage line charging curve

When applied the 180V DC trip voltage charges the line based on an RC timing curve. The time taken to reach the trip threshold at each remote station is dependant on the pilot line impedance & the number of stations. Typically 10ms.

3. Intertrip Receive Element

The intertrip receive element is designed for immunity to 50Hz AC signals up to 400V for 3s. This AC rejection filter adds a typical time delay of between 11 & 22ms.

4. Series Intertrip Receive Relay Contacts

Four high speed series relay contacts are provided for direct tripping of local circuit breakers. This introduces a 7ms delay.

5. Total End To End Intertrip Times

Pilot Line		2 Stations	3 Stations	4 Stations
0Ω	0uF	38ms	42ms	46ms
2,000Ω	0uF	40ms	45ms	52ms
0Ω	2uF	43ms	47ms	51ms
1,000Ω	1uF	45ms	50ms	55ms
2,000Ω	2uF	46ms	47ms	61ms

Typical intertrip times

INTERTRIP SEND INITIATION INPUT

Initiation from a fleeting or continuous input signal may be used as depicted in figure 3. The initiating station will not respond to its own intertrip send signal. During the 2s intertrip pulse the station sending the intertrip signal will not respond to any intertrip receipt signals. Pilot wire supervision functions are suspended during an intertrip event to avoid spurious alarms.

SYSTEM RESET TIME

The station initiating the intertrip send signal will reset 2s after the completion of the 2s intertrip pulse & removal of the initiate signal.

The receive stations will reset 2s after the intertrip signal has concluded. Front panel indicators are hand or electrical reset.

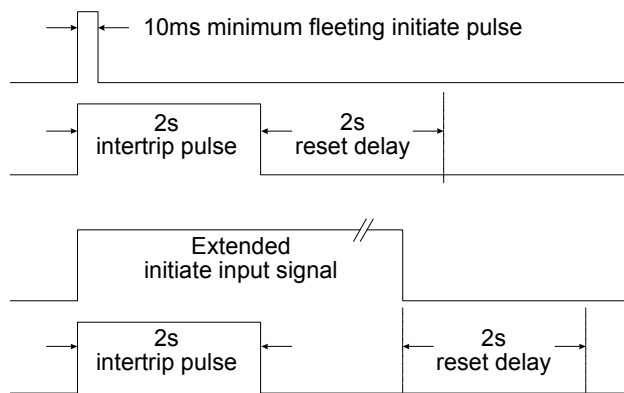

Figure 3

Intertrip Operation

INTERTRIP SEND CONFIGURATION

The intertrip send signal can be set to operate in two modes as shown in figure 4:

CPU Intertrip Mode (Default)

In this mode the intertrip send command is routed through the CPU which introduces a de-bounce time (Default factory setting of ~10ms) to improve system security & is the preferred mode of operation. The default factory configuration is the CPU mode with the direct intertrip send link not fitted.

Direct Intertrip Mode

In this mode the direct intertrip send link is fitted to allow the Intertrip send signal to be fed directly to the intertrip send circuit. This ensures that the intertrip send function will operate even in the event of CPU failure & reduces the typical intertrip times by the ~10ms de-bounce time.

If the direct intertrip mode is to be used it is recommended that the external wiring from the initiate contact to the intertrip send input be kept short & shielded cable employed to reduce the risk of induced voltage signals & possible mal operation. The relatively high operate current of this input is designed to improve security.

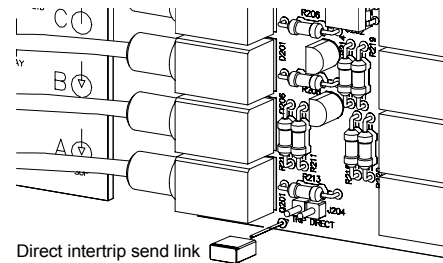

Figure 4

PILOT WIRE ISOLATION

The 5KV & 15KV RMS isolation level is achieved using a compact encapsulated isolating transformer & fibre optic links.

Isolating Power Supply

Isolation is provided between the pilot wires & all other case terminals. This is achieved within the device using a specially fabricated high voltage isolating transformer. *No external isolating components are required.*

Intertrip Send & Receive

Transmission of the intertrip send & receive signals across the high voltage isolation barrier is achieved using an optical transmitter, optic fibre cable, & optical receiver.

Supervision Signal Send & Receive

Supervision send & receive signals are transmitted across the high voltage isolation barrier using an optical transmitter, optic fibre cable & optical receiver.

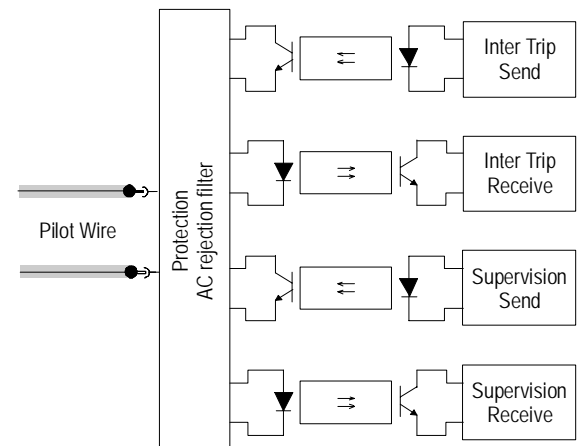
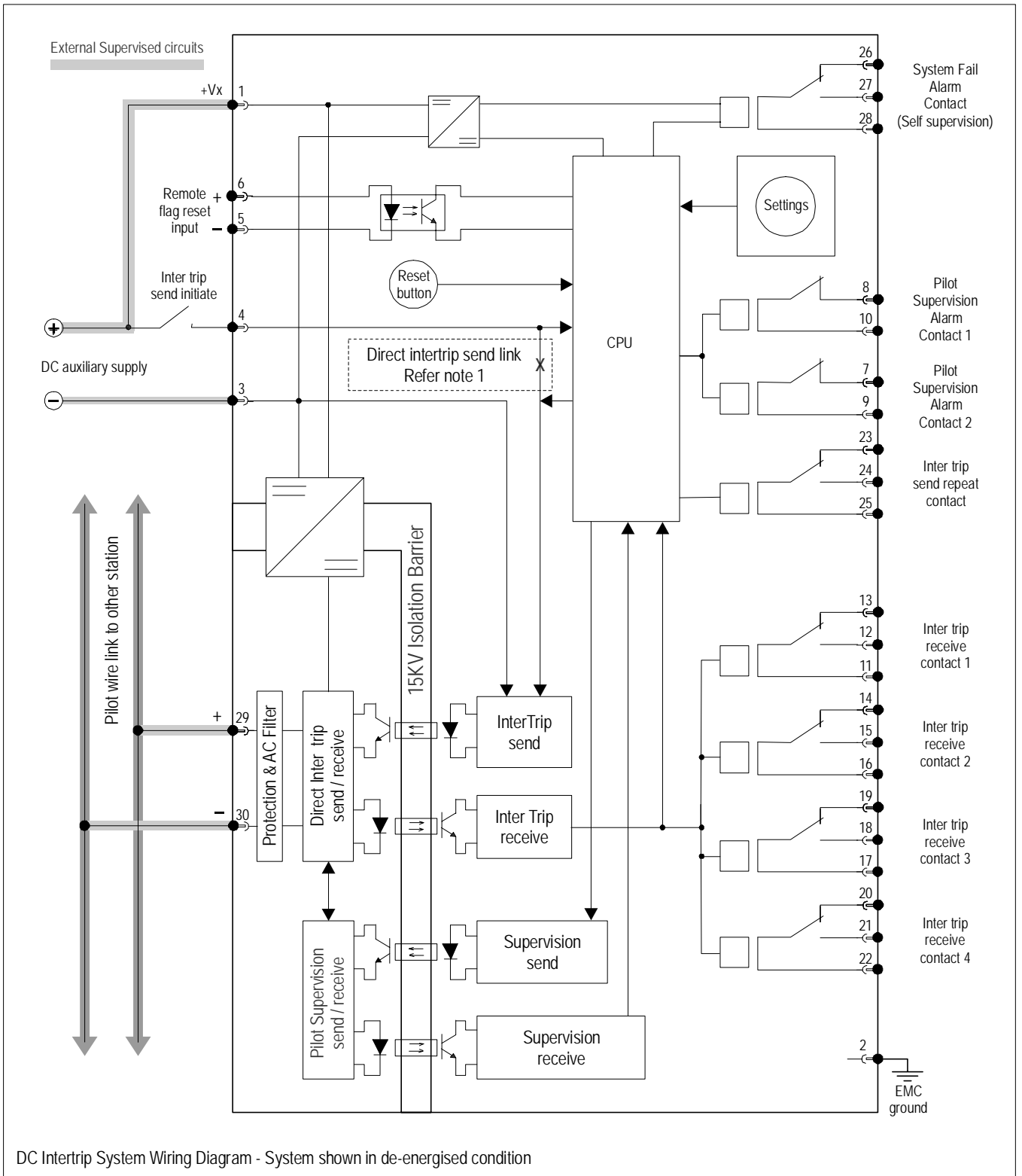

Figure 5: Fibre optic links across isolation barrier block diagram



DC Intertrip System Wiring Diagram - System shown in de-energised condition

Figure 6

Note 1: The factory default mode of operation is with the direct intertrip link removed. Refer to the Intertrip Send Configuration section for details. The direct intertrip send link may be fitted in the field by a qualified technician.

Note 2: If the 3A300 is mounted in a metal cubicle or rack the EMC ground must be connected to the chassis ground.

3A300

SUPERVISION SETTING MODE

The intertrip supervision mode is selected using the dial selection on the front panel. OFF, Continuous & Pulse modes are available as depicted in figure 7. Unless supervision is turned OFF, one station must be set as the Master & all other stations as Slaves.

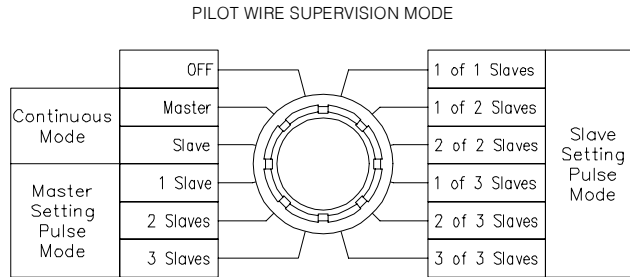

Figure 7

PULSE MODE PILOT WIRE SUPERVISION

In this mode the Master unit outputs a DC pulse code as per figure 8. At the 750ms point the Slave units decode this signal as the Master supervisory interrogation pulse & establish synchronization for the supervision sequence. Each Slave responds in turn with a single 250ms DC pulse. The Master unit & each other Slave unit detect this return DC pulse to maintain the pilot wire supervision healthy LED's (Figure 9).

An important attribute of this mode of operation is that each station monitors all other stations for their return pulse sequence to confirm correct supervision function.

If a station fails to detect a supervision pulse an alarm timer equivalent to three supervision cycles is started. This results in a nominal supervision time delay of 4.5s for 1 slave, 6s for 2 slaves & 7.5s for 3 slaves. Recovery of the lost supervision pulse during this interval will reset the timer. Expiration of the timer will cause the supervision alarm contacts to be set.

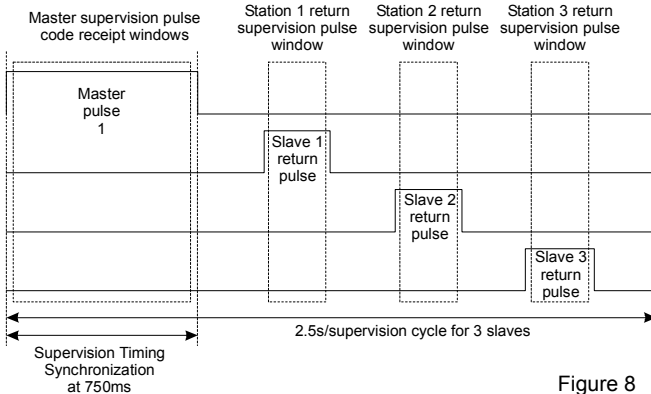

Figure 8

Timing diagram for a single supervision cycle

If the master station reset button or remote reset status input is activated for 2s a re-start will be initiated which will automatically re-synchronize the supervision system at all stations.

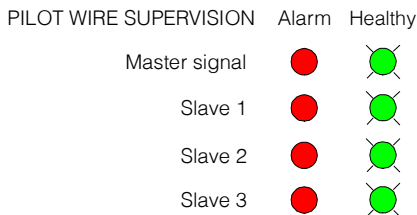

Figure 9

Flashing red alarm LED's indicate an ongoing pilot supervision failure condition. Solid red LED's indicate a pilot supervision alarm has occurred but has been corrected. Press the reset button to clear.

Only the green Healthy & red alarm LED's for connected slave stations are active.

Pilot Wire Supervision

PILOT OPEN CIRCUIT FAULT LOCATION (Pulse mode)

Both the master & slave stations are able to detect pilot open circuit faults. In the simple two station configuration (Figure 1) an open circuit fault will cause the slave to display a Master Signal alarm. The Master will display a Slave 1 alarm.

Where additional slaves are installed the alarm displayed will depend on their position on the pilot relative to the master station and the pilot open circuit. If they are on the other side of the master away from the fault they will display a Slave 1 alarm. If they are positioned after slave 1 away from the master they will display a Master Signal alarm.

PILOT SHORT CIRCUIT FAULT LOCATION (Pulse mode)

A loss of insulation resistance across the pilot cores will lead to a reduction in the supervision voltage level applied to the pilots. A low resistance or short circuit will cause the supervision signal to be eventually lost & the associated pilot fail alarms being signaled.

CONTINUOUS MODE PILOT WIRE SUPERVISION

In this mode the Master unit outputs a continuous 30V DC unloaded supervision signal. Each Slave & the Master monitors this signal & outputs an alarm if the signal is lost for a pre set time delay.

The advantage of this mode is simplicity. The disadvantage is that the master station will not detect pilot shorts or open circuits & the system does not provide any information on the location of the pilot fault.

In continuous supervision mode only the master signal LED's are utilized as depicted in figure 10. The slave alarm & healthy LED's remain extinguished in this mode.

Under normal conditions all stations will have the green Master signal Healthy LED energised. Failure of a slave station to detect the supervision signal from the master will change state to energize the red Alarm LED after a nominal delay of 7.5s. Supervision alarms must be cleared at each station using the front panel reset button or remote reset status input.

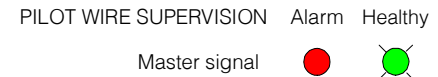

Figure 10

PILOT WIRE SUPERVISION ALARMS

A green Healthy & a red Alarm LED is provided to report faults for each 3A300 station connected on the scheme. The function of these LED's is dependant on the supervision setting mode. Pilot wire supervision alarms are inhibited during intertrip events.

The pilot wire supervision alarm relay contacts are normally closed and are picked up only when all pilot wire supervision alarm Healthy LED's are energized. The pilot wire supervision alarm relay contacts will drop out if any of the pilot supervision red alarm LED's are flashing.

When a fault is detected the corresponding Healthy LED is extinguished, the red Alarm LED flashes & the alarm relay contacts drop out.

Flashing red alarm LED's indicate an ongoing pilot supervision failure condition. Solid red LED's indicate a pilot supervision alarm has occurred but has been corrected. In this condition the alarm contacts self reset to the picked up condition & the corresponding green Healthy LED is re-energised.

Alarm LED's can be reset by pressing the front reset button or activating the remote reset status input. If the fault is persistent the alarm condition will be re-established after the nominal 7.5s delay time.

SUPERVISION OFF MODE

With the pilot wire supervision mode selection switch set to OFF all of the alarm & Healthy LED's remain extinguished. The alarm contact outputs remain inhibited.

This mode is useful for operating the 3A300 as an intertrip send station with existing DC intertrip relays.

3A300

SYSTEM RELIABILITY

System reliability is primarily achieved through the application of proven technology for the critical intertrip send & receive elements. The use of high integrity optical transmitters & receivers combined with periodic supervision minimizes the potential for un-detected failure to cause a non operation at the time of an intertrip event.

The DC/DC converter power supply is of robust design & incorporates considerable protection against pilot line transients & short circuit pilots. Continuous supervision of the DC intertrip & pilot supervision voltage levels is incorporated.

MANUAL SELF TEST SEQUENCE

When the 3A300 is first powered up a complete system self test routine is performed including a sequential LED test. The system monitoring described in this section then commences. A manual self test sequence can be initiated by pressing & holding down the reset button for 2s.

SELF SUPERVISION ALARM CONTACT

Extensive self supervision features have been incorporated to monitor complete system integrity & output an alarm in the event of failure.

Detection of any system fault will cause the green Self Supervision "healthy" LED to flash & the normally energized Self Supervision fail alarm contact to drop out.

SELF SUPERVISION



For diagnostic purposes three red alarm & three green healthy LED's are provided for fault identification. The function of these LED's are described in the following sections.

POWER SUPPLY

Auxiliary Supply Rail

Failure of the power supply will cause all LED's to be extinguished & the Self Supervision fail alarm contact to drop out.

Intertrip Send Voltage

Availability of the DC intertrip voltage is critical to ensure reliable intertripping whenever an intertrip send initiate signal is received. A voltage monitoring circuit is provided for this purpose. Failure of this element is reported via the Self Supervision fail alarm contact & the green healthy Intertrip Send Voltage LED being extinguished.

Intertrip Send Voltage



Supervision Send Voltage

Availability of the DC supervision voltage is required to ensure correct operation of the pilot wire supervision system. A voltage monitoring circuit is provided for this purpose. Failure of this element is reported via the Self Supervision fail alarm contact & the green healthy Supervision Send Voltage LED being extinguished. Failure is also likely to raise pilot wire supervision alarms depending on the supervision mode selected.

Pilot Supervision Voltage



CPU WATCH DOG

A CPU watchdog is employed to monitor the system for correct function. The CPU performs memory & program checks & if no fault is detected a check pulse is output to reset an independent alarm timer. Failure of the CPU to provide the periodic check pulse will cause the alarm timer to expire, the Self Supervision Healthy LED to be extinguished, the CPU Alarm LED to be energised & the Self Supervision fail alarm contact to drop out. This method is employed to ensure the self supervision system is fail safe in the event of its own failure.

CPU Alarm



Self Supervision

INTERTRIP SEND INPUT CIRCUIT

Provision has been made for supervision of the intertrip DC supply & the intertrip send element.

Loss of supply or failure of the intertrip send coil will result in the Intertrip Send Circuit Alarm LED to be energised & the Self Supervision fail alarm contact to drop out.

Intertrip Send Circuit Alarm



INTERTRIP RECEIVE OUTPUT CIRCUIT

Provision has been made for supervision of the intertrip output circuits on the non isolated side.

Failure of any of the four intertrip receive relay coils will cause the Intertrip Receive Circuit Alarm LED to be energised & the Self Supervision fail alarm contact to drop out.

Intertrip Receive Circuit Alarm



INTERTRIP SEND & RECEIVE OPTICAL LINK SELF TEST

The functional integrity of the optical fibre links depicted in figure 10 is monitored by the CPU. This is achieved independently at each station with a periodic 0.3ms intertrip pulse which is long enough to be captured by that stations intertrip receiver but not long enough to be detected by any other station on the pilot.

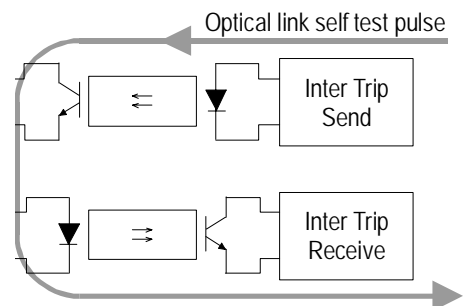

Failure of a test pulse signal being returned to the CPU will result in the Self Supervision fail alarm contact to drop out & **both** the Intertrip Send Circuit Alarm & Intertrip Receive Circuit Alarm LED's to be energised.

Intertrip Send Circuit Alarm



Intertrip Receive Circuit Alarm



The interval between the intertrip self test pulses is dependant on the pilot wire supervision mode setting. In continuous mode the test interval is 25s. In pulse mode the interval is 10 pulse cycles; ie 15s for 1 slave, 20s for 2 slaves & 25s for 3 slaves. In the event that an error is detected an additional 2.5s delay is added to re-check the optic fibre circuit before an alarm is issued.

PILOT SUPERVISION ACTIVITY MONITOR

A Pilot Supervision Activity LED is provided for confirmation that the supervision system is functioning correctly. In continuous supervision mode this LED is continuously energised to indicate correct operation.

In pulse supervision mode the LED is flashed each time the station outputs a supervision pulse to indicate correct function.

Pilot Supervision Activity



3A300

AUXILIARY SUPPLY

Vx: 40-150V DC

AUXILIARY SUPPLY BURDEN (At 110V DC)

Configured as Master: <12W in continuous supervision mode
<10W in pulse supervision mode
<16W in intertrip mode

Configured as Slave: <8W in continuous supervision mode
<8W in pulse supervision mode
<15W in intertrip mode

PILOT WIRE OUTPUT VOLTAGE (Unloaded)

Intertrip voltage: 180V DC +/-5%
Supervision voltage: 30V DC +/-5% - Set as Master

INTERTRIP SEND INITIATE INPUT

Intertrip send pick up range: 25-150V DC
Intertrip send drop off: <10V DC
Minimum pick up current: >20mA
Intertrip initiate signal pulse: >15ms will initiate a 2s intertrip pulse
Intertrip initiate reset: >50ms initiate interruption

The intertrip initiate input meets the requirements of ESI48-4 EB2 at 48V DC nominal initiate voltage. Where compliance is required for 110/125V DC nominal initiate voltages, an external 1,200 ohm 10W dropping resistor must be fitted in series with terminal 4.

PILOT INTERTRIP RECEIVE

Intertrip receive pick up: >70V DC
Intertrip receive drop off: <50V DC

PILOT SUPERVISION RECEIVE

Pilot supervision pick up: >9.1V DC
Pilot supervision drop off: <9.0V DC

REMOTE FLAG RESET INPUT

Operate voltage range: Refer ordering codes for ranges

PILOT WIRE SUPERVISION ALARM DELAY

Continuous mode: 7.5s fixed time delay
Pulse mode: 4.5s for 1 slave system
6.0s for 2 slave system
7.5s for 3 slave system

PILOT WIRE RESISTANCE & CAPACITANCE

The 3A300 system will operate with a maximum 'balanced' pilot line load of 2K ohm resistance & 2uF capacitance. As a guide a pilot wire pair will typically present a 60 ohm resistance & 60nF capacitance per kilometer. This load is depicted in the following figure:

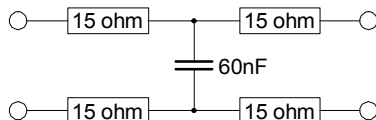

Using this pilot wire characteristic a maximum end to end pilot wire length of 30km is possible.

FRONT PANEL INDICATORS

Healthy LED colour: Green energized solid
Alarm LED colour: Red (Flashing & solid) energized

Self Supervision

Green
CPU Alarm Red
Intertrip Send Circuit Alarm Red
Intertrip Receive Circuit Alarm Red
Intertrip Send Voltage Green
Pilot Supervision Voltage Green
Pilot Supervision Activity Green flashing

Intertripping

Intertrip Send in Progress Latching - hand or electrical reset
Intertrip Receive in Progress Latching - hand or electrical reset

Pilot Wire Supervision

Master Signal Alarm red & Healthy green
Slave 1 Alarm red & Healthy green
Slave 2 Alarm red & Healthy green
Slave 3 Alarm red & Healthy green

Technical Data

AC IMMUNITY OF INTERTRIP RECEIVE ELEMENT

50Hz version: Up to 400V RMS at 50Hz for 3s
60Hz version: Up to 400V RMS at 60Hz for 3s

PILOT WIRE INPUT THERMAL RATING

500V DC & 350V AC continuous
565V DC & 400V AC for 3s

IMPEDANCE PRESENTED TO PILOTS

22.5K ohm & 10nF

OUTPUT CONTACTS

Intertrip receive: 4 C/O contacts
Intertrip send repeat: 1 C/O contact
Pilot wire supervision alarm: 2 N/C contacts
System fail alarm: 1 C/O contact

OUTPUT CONTACT RATINGS

IEC60255-0-2

Carry continuously 5A AC or DC
Make & carry 0.5s 20A AC or DC
L/R ≤ 40ms & V ≤ 300V 0.2s 30A AC or DC
Break capacity AC resistive 1,250VA
I ≤ 5A & V ≤ 300V DC resistive 250VA @ PF ≤ 0.4
DC inductive 75W
30W @ L/R ≤ 40ms
50W @ L/R ≤ 10ms
Minimum number of operations 10⁶ at maximum load
Minimum recommended load 0.5W limit 10mA / 5V

TRANSIENT OVERVOLTAGE

IEC60255-5 CLASS III

Between all terminals & earth 5kV 1.2/50us 0.5J
Between independent circuits without damage or flashover 5kV 1.2/50us 0.5J

INSULATION COORDINATION

IEC60255-5 CLASS III

Between all terminals & earth 2.0kV RMS for 1 minute
Between independent circuits 2.0kV RMS for 1 minute
Across normally open contacts 1.0kV RMS for 1 minute
Between all input terminals & pilot wire terminals 5KV RMS or 15KV RMS for 1 minute
Between all output terminals & pilot wire terminals 5KV RMS or 15KV RMS for 1 minute

AUXILIARY SUPPLY

IEC60255-11

Allowable breaks / dips in supply ≤ 20ms
Collapse to zero from nominal voltage

HIGH FREQUENCY DISTURBANCE

IEC60255-22-1 CLASS III

2.5kV 1MHz common mode No mal operation
1.0kV 1MHz differential mode

ELECTROSTATIC DISCHARGE

IEC60255-22-2 CLASS III

6kV contact discharge No mal operation

RADIO FREQUENCY INTERFERENCE

IEC60255-22-3

10V/m, 80 TO 1,000MHz No mal operation

FAST TRANSIENT

IEC60255-22-4

4kV, 5/50ns, 2.5KHz repetitive No mal operation

CONDUCTED RFI

IEC60255-22-6

10V, 0.15 to 80MHz No mal operation

TEMPERATURE RANGE

Operating: -5 to +55°C
Storage: -25 to +75°C

HUMIDITY

IEC68-2-1/2

40 °C & 95% RH non condensing

3A300

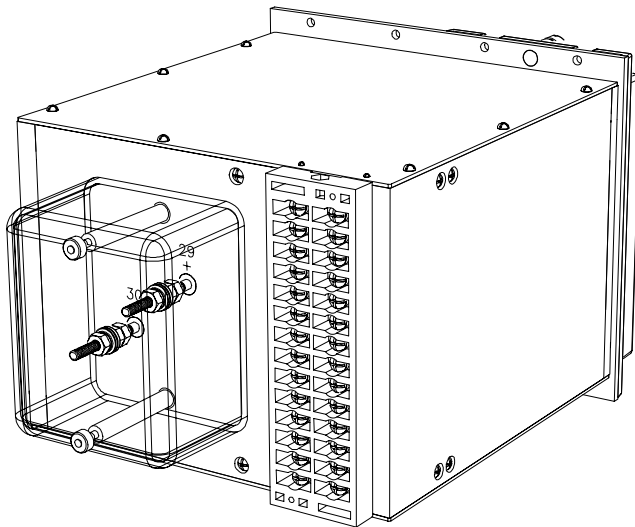

Rear view showing pilot wire & secondary terminations

Mounting Details

CASE
 19" rack or flush mounting: 4U high rear connection
 5KV isolation size 6 case
 15KV isolation size 8 case

Front connection surface mounting version also available.

IP rating: IP5x
 Construction: Acetal & fiberglass.
 Separate pilot wire termination cover provided for the 15KV isolation version.

REAR TERMINALS
 Pilot cables: M5 studs.
 Secondary wiring: 28 M4 screw terminals suitable for ring lugs

FRONT PANEL DETAILS & DIMENSIONS

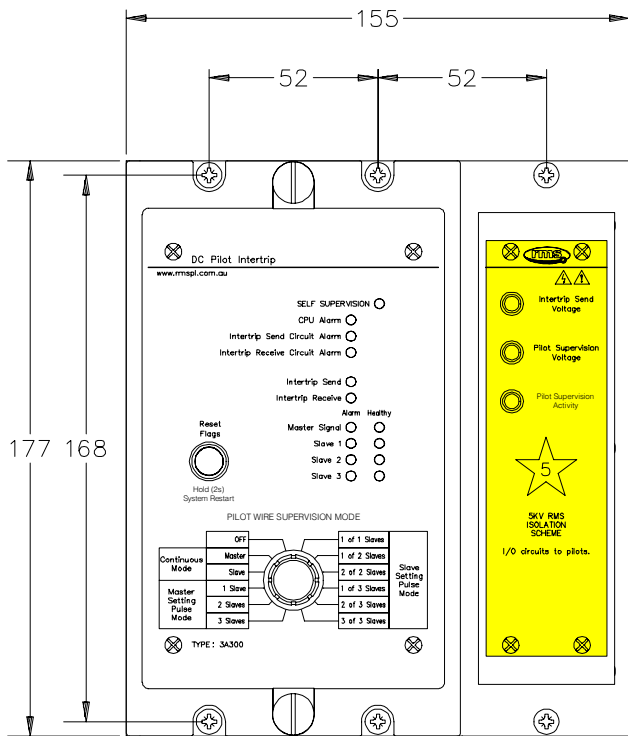

Size 6
5KV Isolation Version

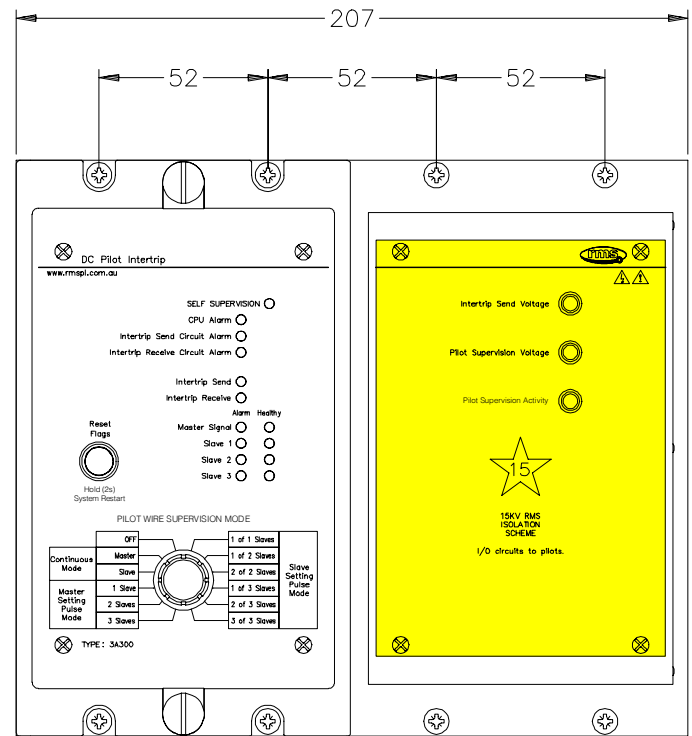

Size 8
15KV Isolation Version

Mounting Details

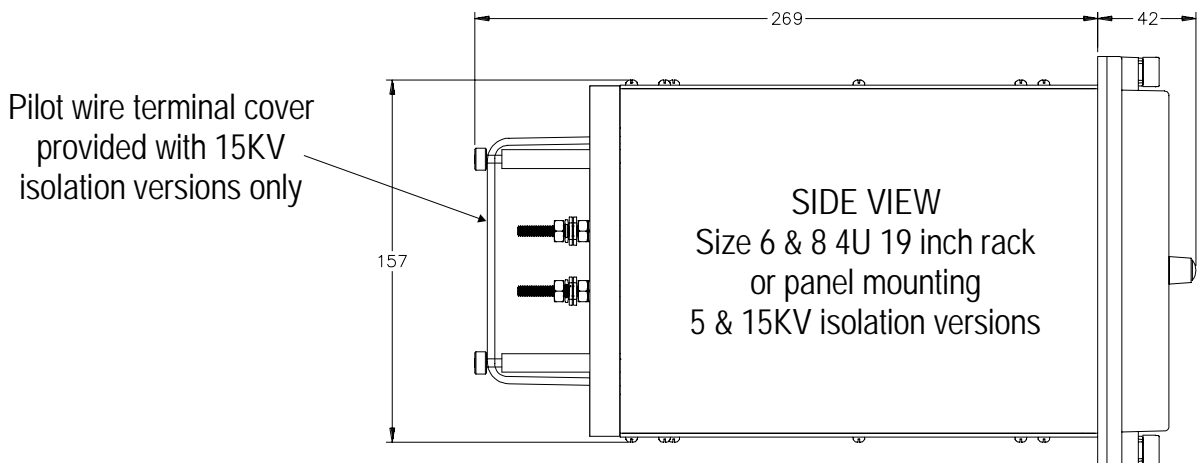
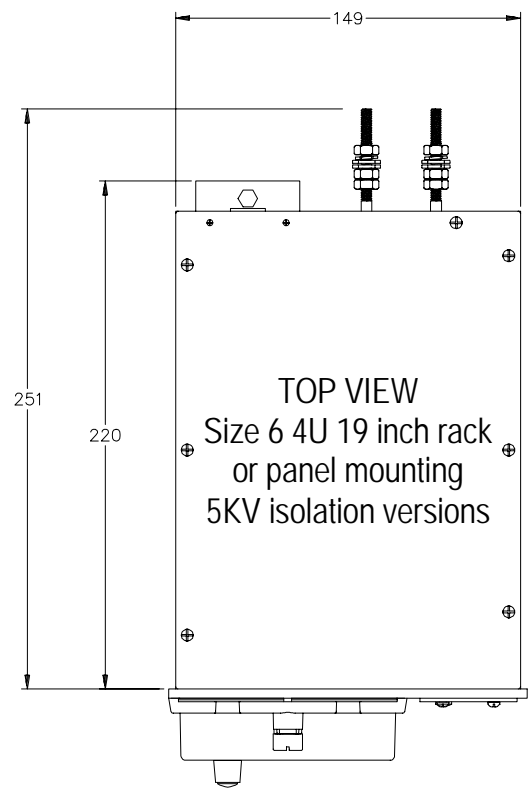
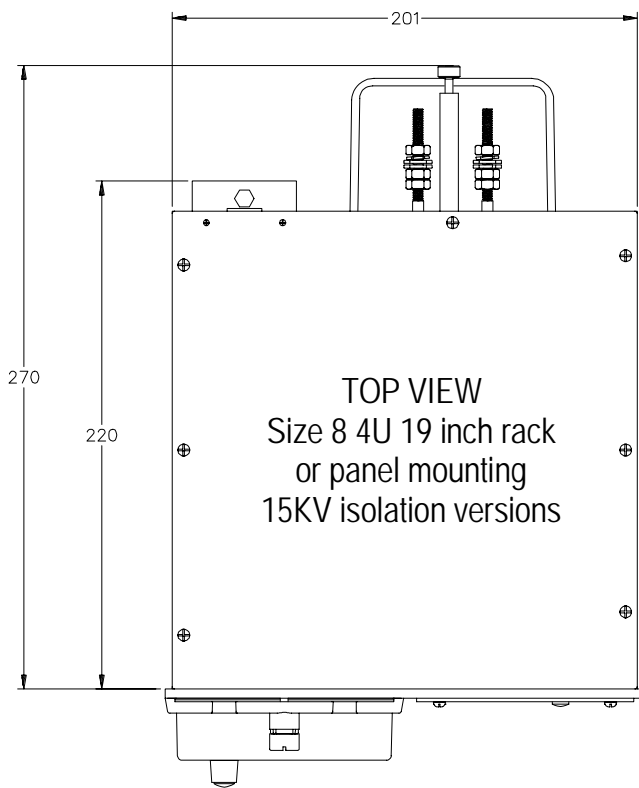
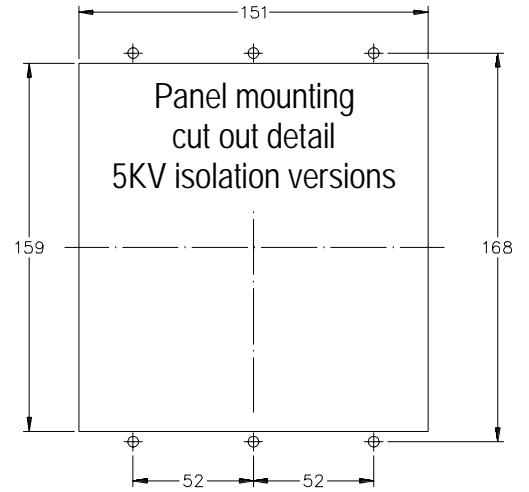
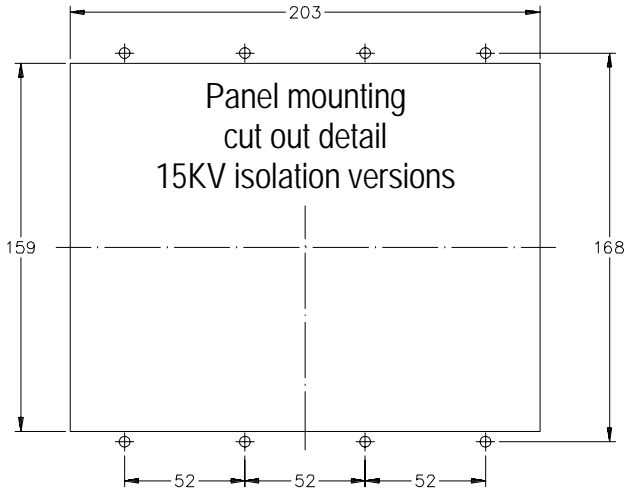

3A300

Ordering Information

Generate the required ordering code as follows: e.g. 3A300-BBBA

3A300 -

1	2	3	4
<input type="text"/>	<input type="text"/>	<input type="text"/>	<input type="text"/>

1 AUXILIARY SUPPLY RANGE

- B 40-150V DC with 50Hz AC rejection filter
- D 40-150V DC with 60Hz AC rejection filter

2 PILOT WIRE ISOLATION LEVEL

- A 5KV RMS
- B 15KV RMS

3 INTERTRIP & REMOTE RESET STATUS INPUTS

- A 24-80V DC
- B 75-150V DC

4 CASE MOUNTING

- A 4U high rack or flush mounting

Made in Australia
Relay Monitoring Systems Pty Ltd
P.O. Box 166
Huntingdale
Melbourne
Victoria 3166
Australia
Phone: +61 (3) 9561 0266
Fax: +61 (3) 9561 0277

E-mail: rms@rmspl.com.au

www.rmspl.com.au/spdl.htm

© 2010 Relay Monitoring Systems Pty Ltd

Due to RMS continuous product improvement policy this information is subject to change without notice.