

6RJ21

Fact Sheet

High Burden Self Reset High Speed Trip Relay

Features

- High speed operation
- High burden
- Self reset contacts
- High visibility latching flag indicator with hand reset mechanism
- 5 to 10 contacts
- Other contact arrangements up to 13 M or B available
- Compact size 2 draw out case
- 2HSM512 specification

Application

The effect of a fault on a power system is dependent on the speed with which the fault can be detected & isolated. The 6RJ Series multi-contact high-speed trip relays are used for this isolating function providing simultaneous tripping outputs.

A high speed coil provides fast operation (<10ms at nominal voltage), with specially constructed anti bounce buffers ensuring effective damping of the contacts to avoid excessive bounce.



6RJ21 in a 2M28-S draw out case

High Burden 5 to 10 Contact Tripping Relay

The 6RJ21 is a high burden self reset tripping relay suitable for application in high security circuit breaker tripping circuits & in particular where the initiating contact may be remote from the relay. The high burden may also allow the satisfactory operation of external series elements.

The 6RJ21 has a high burden to provide immunity to capacitance discharge currents & power to the coil is cut off at operation or is economized to a low figure to provide thermal protection.

High burden tripping relays are designed to withstand the 10uF capacitor discharge test such that the relay will not operate when a 10uF capacitor charged to 120% of nominal operating voltage is applied across the coil of the relay.

The contacts & trip flag indication operate on application of a control voltage. Contacts are reset upon removal of the control voltage. The flag is reset using the front panel push button provided the contacts are in the reset position.

Series Elements

External relay elements are often employed for additional flagging & alarm functions. These elements are typically much slower than the primary high speed tripping relay so care must be taken to ensure reliable operation of the series element before the series trip signal is cut off or economized. In these circumstances a 6RJ relay with a time delayed (TD) cut off should be employed.

6RJ21

Terminal Wiring

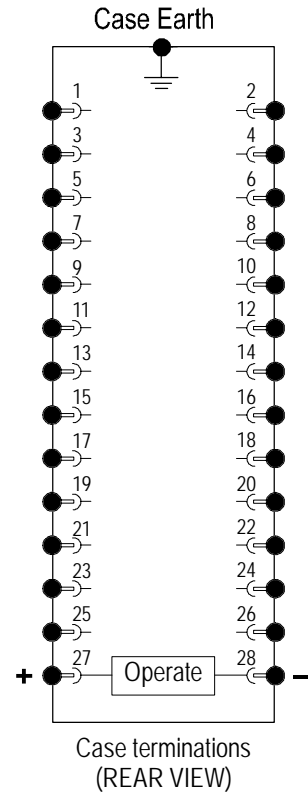

6RJ21-5 Terminal Numbers					
Contacts	1-3	2-4	5-7	6-8	9-11
5M	M	M	M	M	M
4M+1B	M	M	M	M	B
3M+2B	M	M	M	B	B
2M+3B	M	M	B	B	B
1M+4B	M	B	B	B	B
5B	B	B	B	B	B

6RJ21-10 Terminal Numbers										
	1-3	2-4	5-7	6-8	9-11	10-12	13-15	14-16	17-19	18-20
Contacts	1	2	3	4	5	6	7	8	9	10
10M	M	M	M	M	M	M	M	M	M	M
9M+1B	M	M	M	M	M	M	M	M	M	B
8M+2B	M	M	M	M	M	M	M	M	B	B
7M+3B	M	M	M	M	M	M	M	B	B	B
6M+4B	M	M	M	M	M	M	B	B	B	B
5M+5B	M	M	M	M	M	B	B	B	B	B
4M+6B	M	M	M	M	B	B	B	B	B	B
3M+7B	M	M	M	B	B	B	B	B	B	B
2M+8B	M	M	B	B	B	B	B	B	B	B
1M+9B	M	B	B	B	B	B	B	B	B	B
10B	B	B	B	B	B	B	B	B	B	B

Wiring terminal numbers for other contact configurations may be inferred from the above tables. For example for a 6 contact relay with 4M + 2B contacts use the 4M+6B contact row as far as terminals 10-12.

6RJ21

Technical Data

CONTACT BOUNCE & SELF CLEANING

Contact bounce occurs due to the speed at which the contacts meet. If too much coil power is used then the contacts will come together with too much force causing excessive bounce. It is therefore important to only fit relay coils with adequate power to provide the force required to switch the relay at the minimum operate voltage 65% of nominal.

In addition contact bounce can be greatly reduced through the addition of anti-bounce buffers. These components are added to each contact to provide a damping wiping motion when the contacts meet thus dissipating the force which would otherwise produce bounce.

Contacts are constructed from silver / copper alloy, shaped & positioned to ensure very reliable, low resistance operation. Over travel of the contacts during each operation causes a wiping action ensuring a clean "make".

The design of the contact surface is spherical such that when the contacts are driven to an over travel position they actually wipe. This wiping motion is part of the damping action mentioned above but also provides a wiping action which serves to clean the contact area.

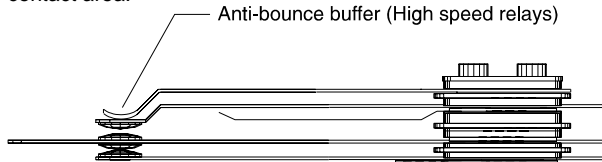

6R MATRIX relays are "All or Nothing" devices & continuous application of AC or DC voltages below the pick up level is not recommended.

AC VOLTAGES

Standard 2HSM relays are not intended for operation with AC voltages. Application of continuous AC voltage below the pick up level will cause excessive power dissipation in the capacitor discharge resistor & likely result in thermal damage to the device.

CONTACT RATINGS

Make & Carry Continuously

3,000 VA AC resistive with maximums of 660V & 12A
3,000 W DC resistive with maximums of 660V & 12A

Make & Carry for 3 Seconds

7,500 VA AC resistive with maximums of 660V & 30A
7,500 W DC resistive with maximums of 660V & 30A

AC Break Capacity

3,000 VA AC resistive with maximums of 660V & 12A

DC Break Capacity (Amps)

Voltage			24V	48V	125V	250V
Resistive rating		1	12	12	10	5
		2	12	2	0.5	0.25
L/R=40ms	Maximum break	1	30	15	5.5	3.5
		2	12	1	0.25	0.15
	1K operations (N3 Rating)	1	12	12	5	2.5

1 = With magnetic blowouts 2 = Without magnetic blowouts

6R MATRIX Pre-Defined relay versions are supplied as standard without magnetic blowouts. If magnetic blowouts are needed for special applications this requirement must be specified when seeking quotation & placing orders.

OPERATING BURDEN (Burden during pick up at nominal)
High burden relays: 150W Maximum

OPERATED BURDEN (Burden after pick up at nominal)
Self reset contacts: 5W Maximum

COIL THERMAL RATING

All operate circuits are designed to withstand continuous application of 120% of nominal voltage. The high speed operate coil element (150 watt max.) has a thermal rating of 30 seconds, however this is protected by use of the series economy coil.

CONTACT OPERATION

Self reset contacts. N/O contacts pick up when the relay is energised & drop out when the operate voltage is removed.

OPERATING TIME

Less than 10ms at nominal rated operating voltage.

FLAG OPERATION

Each relay element is supplied with an operation (target) indicator.

The indicator consists of a high visibility solid day glow orange mechanical flag which drops on energisation.

Drops on coil energisation.

Hand reset when the contacts are in the reset position.

OPERATING VOLTAGE RANGE

Guaranteed operation between 65% & 120% of nominal rated operating voltage.

RESET VOLTAGE

Self reset relays will reset at not less than 5% of nominal rated operate voltage.

AC VOLTAGES

Standard 6RJ relays are not intended for operation with AC voltages. Application of continuous AC voltage below the pick up level will cause excessive power dissipation in the capacitor discharge resistor & likely result in thermal damage to the device.

NOMINAL OPERATING VOLTAGES

24, 32, 48, 110, 125, 220, 240 & 250V DC available.

MINIMUM OPERATING CURRENT

High burden relays: 100mA

CONTACTS

10 contacts standard

Other contact arrangements up to 13 M or B available

User to specify combination of make & break contacts

INSULATION WITHSTAND in accordance with IEC 255-5:

2KV RMS & 1.2/50 5KV impulse between:

- ◆ all terminals & frame
- ◆ each contact group
- ◆ all contacts & coil

CAPACITOR DISCHARGE TEST

The 6RJ21 is a high burden tripping relay designed for high security applications where the circuit may be subject to voltage transients.

To allow for this contingency high burden tripping relays are designed to withstand a 10uF capacitor discharge test such that the relay will not operate when a 10uF capacitor charged to 120% of nominal operating voltage is applied across the coil of the relay.

6RJ21

CASE SIZE

2M28-S draw out case
Refer to the M Series case Technical Bulletin for additional details.

Ordering Codes

Generate the required ordering code as follows:

e.g. 6RJ21-10-D-8M2B

6RJ21

1

2

3

1 NUMBER OF CONTACTS

- 5 5 contacts
- 6 6 contacts
- : :
- : :
- 10 10 contacts

2 NOMINAL OPERATE VOLTAGE

- | | |
|-----------|-----------|
| A 24V DC | E 125V D |
| B 32V DC | G 220V DC |
| C 48V DC | H 240V DC |
| D 110V DC | F 250V DC |

3 CONTACT ARRANGEMENT (Not to exceed maximum)

Specify the number of "MAKES" followed by M; i.e. 8M
Specify the number of "BREAKS" followed by B; i.e. 2B

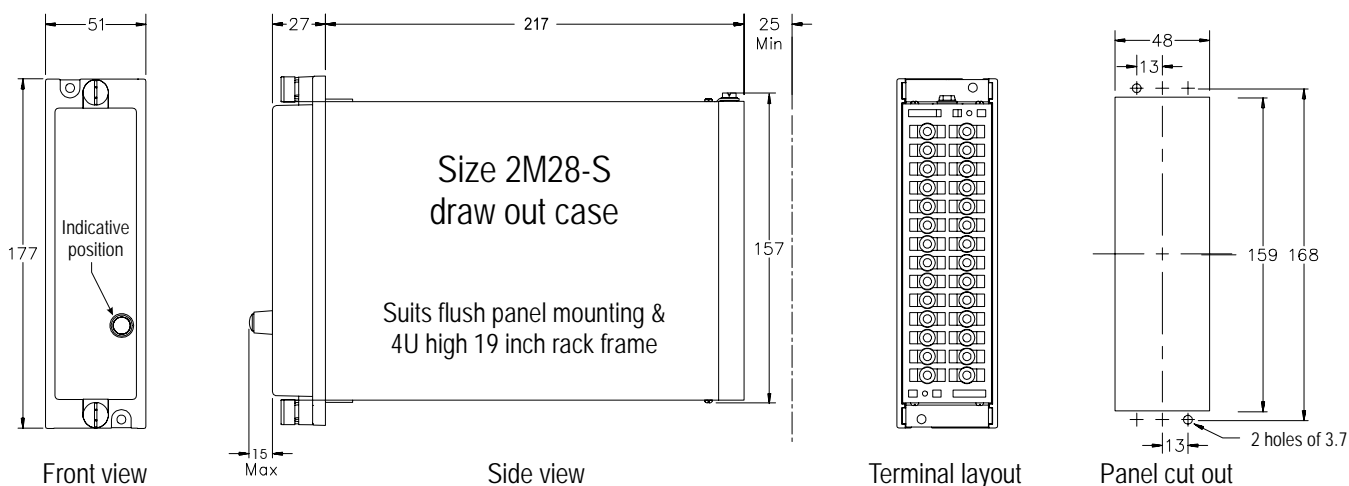

Made in Australia
Relay Monitoring Systems Pty Ltd
P.O. Box 166
Huntingdale
Melbourne
Victoria 3166
Australia
Phone: +61 (3) 9561 0266
Fax: +61 (3) 9561 0277

E-mail: rms@rmspl.com.au

www.rmspl.com.au/spdl.htm

© 2010 Relay Monitoring Systems Pty Ltd

Due to RMS continuous product improvement policy this information is subject to change without notice.