

Features

- Four time ranges
0-0.99s, 0-9.9s, 0-99s, 0-990s
- High accuracy & repeatability – timing compensated for output relay delay
- Time settings easily selected by digital thumb wheel switches
- Selectable delay operate or delay release
- Optional reset functions
Instantaneous (Fast), definite time, count down
- 4 C/O output contacts
- Wide auxiliary supply range with fail alarm contact
- Timing in progress LED
- Non-volatile trip indication
- Multi voltage timer initiate input
- Multi voltage flag reset input
- Size 2M draw out case

Application

The DDB20 time delay relay is particularly suitable for use in protection & control schemes where precision time delays are required.

CB FAIL

A typical use is for providing a definite time delay in circuit breaker failure protection. For example: The transformer multi-trip relays energize the DDB20 timer & if the circuit breaker (CB) fails to clear the fault within the pre-set (0.6s) the timer times out & operates a multi-trip relay. This in turn trips all CB's on the section of the busbar connected to the CB, which has failed to trip.

INDUCTION DISC RESET EMULATION

Replacement of induction disc timing elements with solid-state relays can result in a loss of grading & reduced functionality due to the different reset characteristics. For example, the inherent slow reset time of induction disc relays provide an advantage in sensitive overcurrent schemes where pecking faults could go undetected due to the timer being instantaneously reset each time the current momentarily falls below the start setting. The DDB20 may be specified with a number of reset functions to avoid this problem & to suit specific protection applications.



DDB20 depicted in a 2M28 case.

Operation

A crystal oscillator & embedded micro controller based timing circuit are employed to provide accurate timing & flexible functionality. When a control signal is applied to the timer initiate input, a counter begins counting down from the thumb wheel switch setting. When the zero is detected, the output relay contacts & flag operate.

Three time ranges are selected via a front panel switch. An internal configuration switch can be used to select a x10 range multiplier to provide up to 990s of precision time delay. Two timing modes are available:

Time delay **ON** mode (Relay starts timing after the initiate control signal is applied & output contact picks up after the pre-set time delay has elapsed) or;

Time delay **OFF** mode (Relay output contact picks up instantaneously when the initiate control signal is applied, starts timing after the initiate control signal is removed & drops out after the pre-set time delay has elapsed).

An amber LED on the front panel indicates when the relay has been initiated & flashes during timing.

The DDB20 timer may be specified with a number of different reset functions to provide instantaneous reset, definite time reset or induction disc reset emulation. These functions are specified at time of order.

A switchmode power supply provides a very wide auxiliary operating range. A relay fail alarm is provided in the form of a C/O contact which is picked up when the auxiliary supply rail & CPU watchdog status is healthy.

DDB20

TIMING FUNCTION / INITIATE SIGNAL INPUT (Status input)

For accurate timing functions the DDB20 detects application or removal of an external voltage control signal. This mode is set using internal configuration switch 2 (Refer order code details). Refer to Table 2 for timing initiate P/U & D/O times.

DELAY OPERATE TIMING FUNCTION

This timing mode is selected using internal configuration switch 3.

The relay is permanently connected to the auxiliary supply & is initiated by the application of a control signal. Application of the initiate signal starts the pre set timing cycle. During timing the front panel initiate LED will flash & then go on solid once the thumbwheel time setting has elapsed, this sets the output relay & visual indicator. The initiate LED is extinguished & the output contacts reset when the initiate signal is removed. After system reset the visual indicator may be reset locally using the front panel push button or remotely via the flag reset input.

To achieve a simple but less accurate delay **ON** function, the initiate signal may be connected directly to the auxiliary supply. Timing will then commence when power is applied to the relay while removal of power will reset the time delay & output relay. This mode is only suitable for longer time delay settings as the switch mode power supply takes 100 – 500ms (Depending on Vx), to start which adds to the inherent time delay.

Delay Operate (ON)

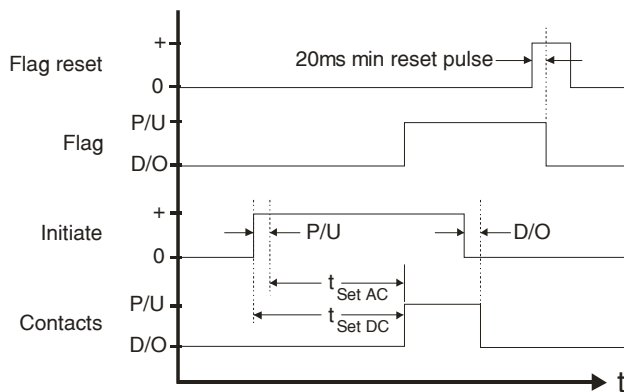

Removal of the initiate signal during timing will reset the time delay (Refer timing reset options). After time out the contacts are reset to the D/O condition upon removal of the initiate signal. The flag can be reset provided the timer initiate signal is removed.

Timing Functions

DELAY RELEASE TIMING FUNCTION

This timing mode is selected using internal configuration switch 3.

The relay is permanently connected to the auxiliary supply. Application of the initiate control signal, causes the output relay to set instantaneously (Rset). It will remain in this state until the control signal is removed; this starts the timing cycle & resets the output relay when the preset time delay is reached.

Delay Release (OFF)

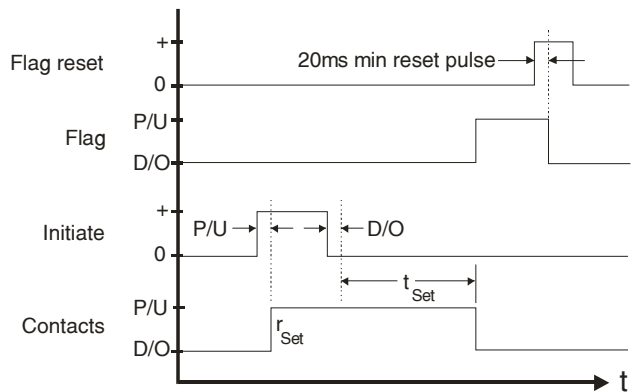

Re-application of the initiate signal during timing will reset the time delay (Refer timing reset options). After time out the contacts are reset to the P/U condition. The flag can be reset at any time, except during timing.

TIMING RESET OPTIONS

Instantaneous

If reset before the preset time delay is reached the timing element will reset (D/O) as per Table 2.

Definite Time Reset (Treset)

If reset before the preset time delay is reached the delay timer will pause until the reset time has elapsed before resetting. If the timer is re-initiated before the reset time has elapsed, the delay timer will restart the timing sequence from the paused timing point.

Count Down Reset

If reset before the preset time delay is reached, the timer will count down toward reset. If the timer is re-initiated before reset is reached the timer will start counting back up towards the time delay pre set.

RESET FUNCTION DIAGRAM

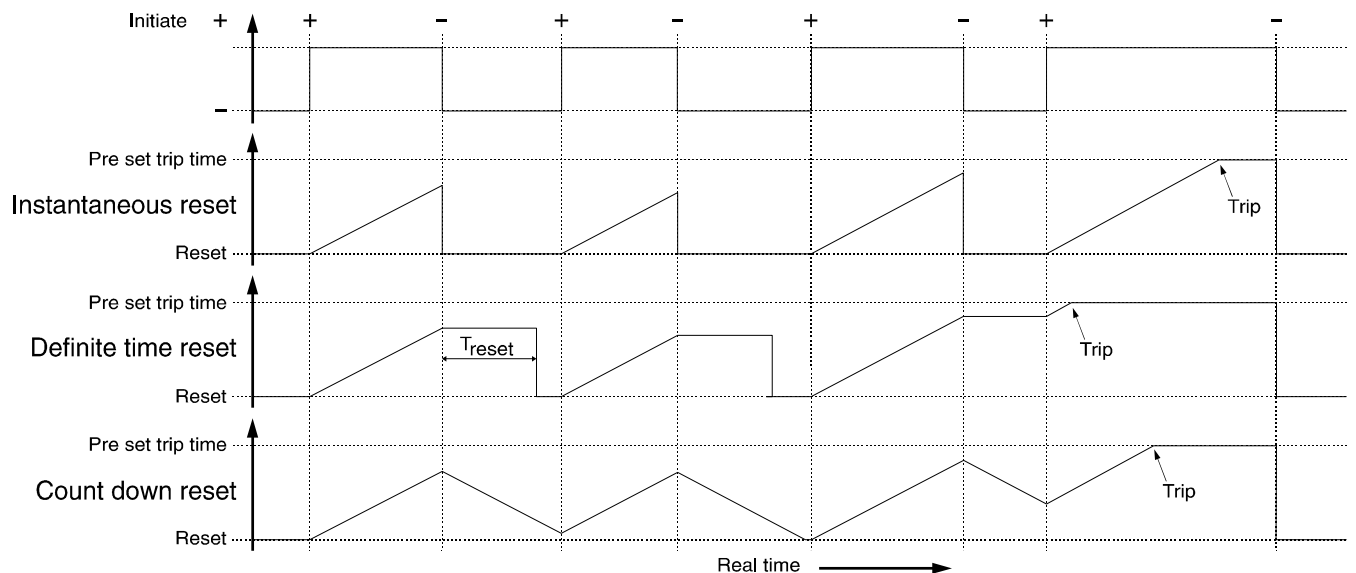

DDB20

Technical Data

AUXILIARY SUPPLY

40-300V DC & 40-275V AC or 20-70V DC switchmode supply.

BURDEN (110V DC nominal supply)

Less than 2 watts during idle & timing.

Less than 4 watts when output relays are energized.

RELAY FAIL ALARM

A C/O alarm contact is maintained in the energized state when all of the following conditions are met:

- The auxiliary supply is applied
- The internal 24V DC rail is within acceptable limits
- The CPU hardware watchdog maintains a pulsing output

A CPU software watchdog records "suspect" events to an assert register & if necessary performs a soft restart.

TIME SETTING RANGES

The DDB20 relay allows for precision time settings of between zero (Minimum operate time) & 990 seconds. This is achieved by the use of two decimal thumb wheel switches & a range multiplication switch on the front panel. A 10x setting multiplier is activated when configuration switch 5 is set to OFF to extend timer range 3 up to 990s.

Range Selector Setting	Achievable Time Setting Range	Resolution of Time Setting
Range 1	Zero to 0.99 Sec	0.01 Sec
Range 2	Zero to 9.9 Sec	0.1 Sec
Range 3	Zero to 99 Sec	1 Sec
Range setting x10	Zero to 990 Sec	10 Sec

Table 1

TIME DELAY SETTING CHANGES

The time delay & function settings should only be changed when the timing initiate LED is extinguished. Time delay settings are read at the beginning of each timing sequence.

TIMER INITIATE STATUS INPUT DELAY

Initiate input	Minimum	AC Rejection Filter	
		ON	OFF
DC	P/U	<16ms	<4ms
	D/O	<4ms	<16ms
AC	P/U	N/A	<23ms
	D/O	N/A	<33ms

Table 2

MINIMUM OUTPUT CONTACT OPERATE TIME

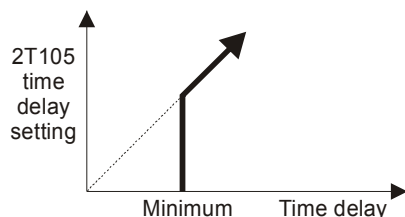

The minimum output contact operate time is equal to the timer initiate status input delays in Table 2 + 6ms. Time delay settings ≤ to this figure will result in a relay contact operate time equal to the minimum.

TIMING ACCURACY

Maximum timing error as a % of setting + uncertainty in ms.

Initiate input	AC Rejection Filter	
	ON	OFF
DC	-0.19% ±0.2ms	
AC	N/A	-0.19% ±10ms

Table 3

CONFIGURATION SWITCHES

Configuration switches are accessible to the user & can be set by withdrawing the relay module & following the instructions on the side plate label. A bank of 5 switches are provided as depicted below & are read each time the DDB20 is powered up:

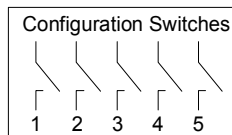

STATUS INPUT OPERATING VOLTAGE (AC rejection filter)

The operating range of the status inputs are set using internal configuration switch 1. This setting may be pre defined when ordering.

18 - 300V DC

Set Configuration Switch to **ON**

In this mode the universal status input will reject AC signals that may be induced on the control wiring. Suitable for high security applications where a DC battery supply is available.

18 - 300V DC & 18 - 275V AC

Set Configuration Switch to **OFF**

In this mode the universal status input is designed to operate on both AC & DC input voltages. Suitable for applications where an AC auxiliary voltage is available such as transformer or generator control panels.

STATUS INPUT MINIMUM OPERATING CURRENT

10mA P/U for 1ms then reducing to 1.5mA after 4ms.

While the function of the configuration switches may vary for special custom models, the standard functions & default settings are described in the Ordering Information section.

FRONT PANEL INDICATORS

Four LED indicators are provided on the front panel:

Power	On solid when auxiliary supply healthy	Green
Timing	Flashing during timing	Amber
Trip	On solid when output relay operated	Red
Range x10	On when the x10 time range selected	Green

The trip LED status is stored in non volatile memory & will be restored when the DDB20 is powered up after loss of the auxiliary supply. The preserved trip LED state is reset using the front panel flag reset button or status input.

A hand & remote reset magnetic disc flag (permanent memory) indicator may be specified as an option. Note that an auxiliary supply is required to reset the flag circuits.

TRANSIENT OVERVOLTAGE

Between all terminals & earth
Between independent circuits without damage or flashover

IEC60255-5 CLASS III
5kV 1.2/50us 0.5J
5kV 1.2/50us 0.5J

INSULATION COORDINATION

Between all terminals & earth
Between independent circuits
Across normally open contacts

IEC60255-5 CLASS III
2.0kV RMS for 1 minute
2.0kV RMS for 1 minute
1.0kV RMS for 1 minute

AUXILIARY SUPPLY

Allowable breaks / dips in supply
Collapse to zero from nominal voltage

IEC60255-11

≤ 20ms

HIGH FREQUENCY DISTURBANCE

2.5kV 1MHz common mode
1.0kV 1MHz differential mode

IEC60255-22-1 CLASS III
≤ 3% variation

ELECTROSTATIC DISCHARGE

6kV contact discharge

IEC60255-22-2 CLASS III
≤ 5% variation

RADIO FREQUENCY INTERFERENCE

10V/m, 80 TO 1,000MHz

IEC60255-22-3
≤ 5% variation

FAST TRANSIENT

4kV, 5/50ns, 100kHz repetitive

IEC60255-22-4
≤ 3% variation

CONDUCTED RFI

10V, 0.15 to 80MHz

IEC60255-22-6
≤ 5% variation

TEMPERATURE RANGE

Operating:
Storage:

IEC68-2-1/2
-10 to +55°C
-25 to +75°C

HUMIDITY

40°C & 95% RH non condensing

IEC68-2-78

OUTPUT RELAY CONTACT CONFIGURATION

4 C/O contacts

OUTPUT CONTACT DWELL TIME

Once operated all time delayed output contacts have a minimum dwell time of 100ms.

OUTPUT CONTACT RATINGS

IEC60255-0-2

Carry continuously	5A AC or DC
Make & carry	0.5s 20A AC or DC
L/R ≤ 40ms & V ≤ 300V	0.2s 30A AC or DC
	AC resistive 1,250VA
Break capacity	AC inductive 250VA @ PF ≤ 0.4
I ≤ 5A & V ≤ 300V	DC resistive 75W
	DC inductive 30W @ L/R ≤ 40ms
	50W @ L/R ≤ 10ms
Minimum number of operations	10 ⁶ at maximum load
Minimum recommended load	0.5W limit 10mA / 5V

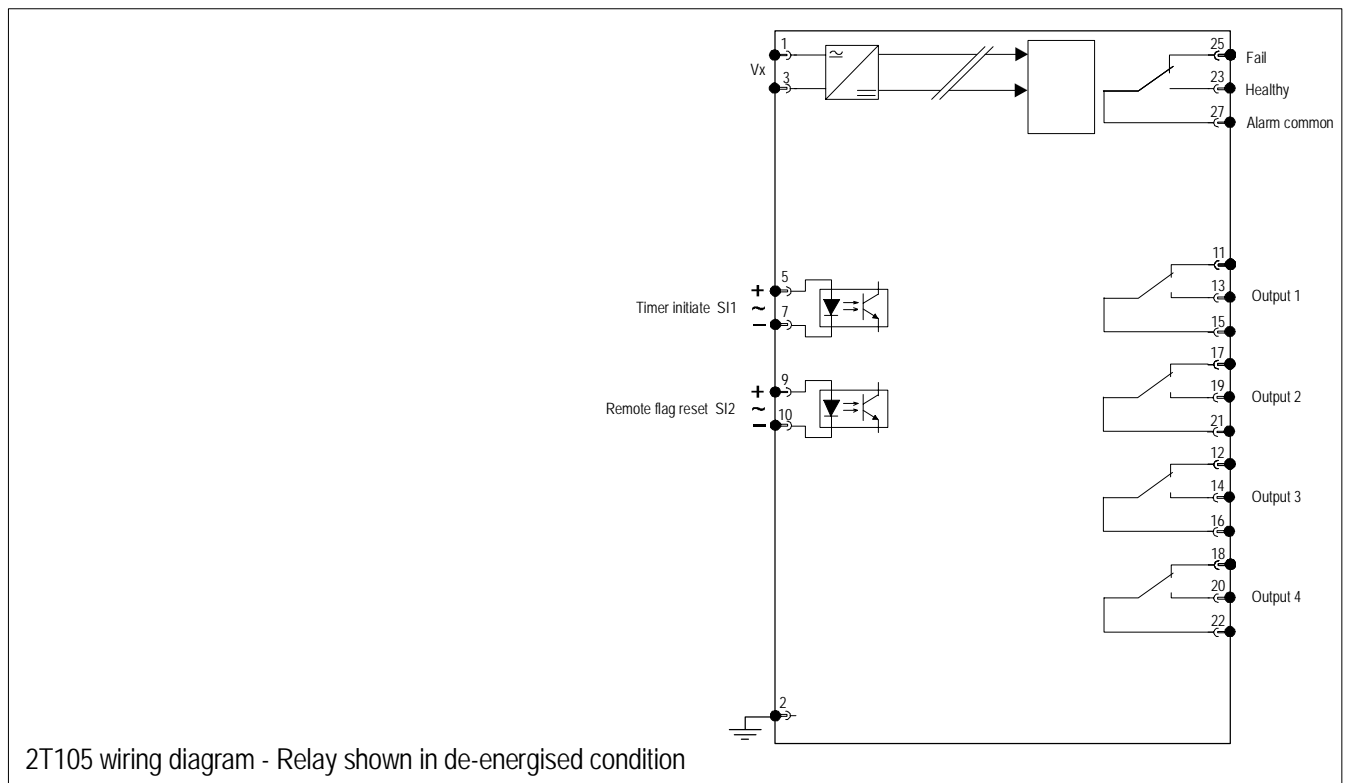

DDB20

Case Details

CASE

Size 2M28-S draw out case

28 M4 screw terminals

Flush panel mount or 4U high 1/8 width 19 inch rack mount

ACCESSORIES SUPPLIED WITH EACH RELAY

1 x M4 self threading mounting screw kit

P/N 290-406-151

1 x M4 terminal screw kit

P/N 290-407-153

1 x Product Test Manual

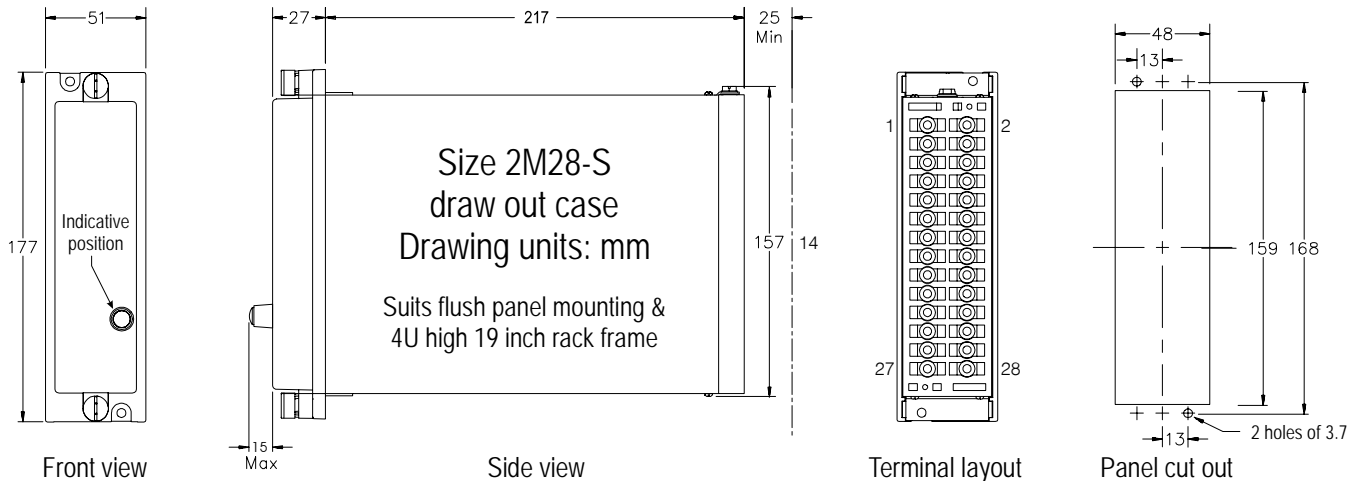
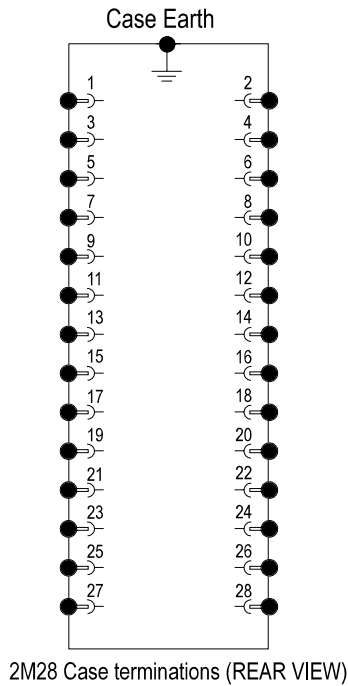

DDB20

CONFIGURATION CODE (Optional specification)

The configuration code can be set in the field by withdrawing the relay module & following the instructions on the side plate label.

The configuration code may be specified at time of order so that the relay will be shipped from the factory pre-set to meet customer requirements. e.g. CONFIG-01011

If a configuration code is not specified the factory default will be set as indicated below. i.e. CONFIG-11111

Specify factory Configuration	Configuration Switches				
CONFIG	1	2	3	4	5

1 STATUS INPUT OPERATION

- 1 ON DC operation only - AC rejection ON (Default)
- 0 OFF AC / DC operation - AC rejection OFF

2 TIMER INITIATE INPUT

- 1 ON Apply volts to initiate (Default)
- 0 OFF Remove volts to initiate

3 TIME DELAY FUNCTION

- 1 ON Time delay OPERATE (Default)
- 0 OFF Time delay RELEASE

4 OUTPUT RELAY FUNCTION

- 1 ON All outputs contacts are time delayed (Default)
- 0 OFF Output contact 4 will operate instantaneously irrespective of the front panel time delay settings.

5 TIME RANGE MULTIPLIER

- 1 ON Selected time range x1 (Default)
- 0 OFF Selected time range x10

Ordering Information

ORDER CODE

The order code determines the production build in the factory & cannot be changed in the field.

Generate the required order code as follows: e.g. DDB20-BAA

General Type	Order Code		
	1	2	3
DDB20			

1 AUXILIARY SUPPLY RANGE

- A 20-70V DC
- B 40-275V AC & 40-300V DC

2 TIMING RESET FUNCTION

- A Instantaneous reset
- B Definite time reset – Treset ____ s
Specify a Treset delay in the range 0.1 to 255s in 0.1s steps
- C Count down reset

3 TRIP FLAG

- A Red LED non volatile trip indication (Standard)
- B Magnetic disc trip flag

Made in Australia
Relay Monitoring Systems Pty Ltd
P.O. Box 166
Huntingdale
Melbourne
Victoria 3166
Australia
Phone: +61 (3) 9561 0266
Fax: +61 (3) 9561 0277

E-mail: rms@rmspl.com.au

www.rmspl.com.au/spdl.htm

© 2010 Relay Monitoring Systems Pty Ltd

Due to RMS continuous product improvement policy this information is subject to change without notice.