

Order Number

Serial Number

Number in Batch

## PRODUCT/TEST MANUAL

**2HSA514K16**

**125V DC HANDRESET MULTI-TRIP RELAY 20M**

Issue Level	Date	Summary of changes
A	27/09/2005	Initial issue.

Due to RMS continuous product improvement policy this information is subject to change without notice.  
This document is uncontrolled and subject to copyright.

Author	Checked & Registered	.pdf file created	Released
ERL	DG	DG	

## 1. ASSOCIATED DRAWINGS

Reyrolle Drawing 2112W50173  
PCI 145 ALPHA Reference Build specification  
PL201 Sample Inspection Plan

## 2. HIGH VOLTAGE TESTING

Using the standard Matrix High Voltage test fixture apply 2KV RMS 50Hz between terminals as in 2.a), 2.b) below.

Repeat the test using three 5KV 1/50us pulses of each polarity between terminals as in 2.a), 2.b) below.

- a) All terminals together to frame
- b) Coil to all contacts plus frame

## 3. TEST PROCEDURE

- a) Determine the sample size for the batch by referring to the Sample Plan on PL 201
- b) Select the samples at random from the batch and check that the minimum and maximum contact gap meets the requirements of PCI 145, using feeler gauges measure the contact gap on all contacts on all contact stacks.  
Check
- c) Manually operate the relay to its latched position, push the armature towards the pole face of the relay. Ensure that a minimal amount of backlash is present and that the contacts have sufficient over travel by ensuring that all of the contacts have made before the armature is fully latched.  
Check
- d) Plug the relay into the Matrix Test panel.
- e) Adjust the auxiliary supply to 120% of nominal (150VDC)
- f) Operate the "CRO & Cap Discharge" switch to on, push "High Speed Relay" button. Ensure that the relay does not operate or the contacts make, a slight flicker is acceptable.  
Check
- g) Connect the coaxial lead from "CH2 Trigger" on the test jig to the external trigger input on the Oscilloscope; connect the "CH1" lead on the test jig to channel 1 input on the oscilloscope. Set the time base to 2 mS. Press the "Start" button and note the waveform on the oscilloscope, the time from the trigger point to the rising edge (N/O contacts) of the waveform on first touch is 12 mS for switch positions 1 - 20  
Check
- h) Make sure that the contact wiring of the relay corresponds to the connection diagram on the side of the relay.  
Check
- i) Check that the relay operates satisfactorily at 120% (150 volts) and 50% (62.5volts DC) and that the armature is fully home.  
Check
- j) Ensure that after the relay has operated and latched that the current in the operating circuit is zero.  
Check

**TEST PROCEDURE (Cont.)**

**4. GENERAL & FUNCTIONAL**

- a) Plug the "Alpha 20 contact" test jig into the test rack and plug in the test relay. Slowly operate the armature by hand and note when each of the front panel LED's illuminate, all LED's should be on by the time the armature is fully home.
- b) Fit elastic band on the flag to prevent damage to the flag mechanism during transport.
- c) Check that the relay is electrically sound and mechanically robust as per Standard Inspection & Test Schedule 903-000-026.

Check

**PASS**

TESTED BY: \_\_\_\_\_ DATE: \_\_\_\_\_

## 6. TEST SETUP & WAVEFORMS

### CONTACT TEST SETUP

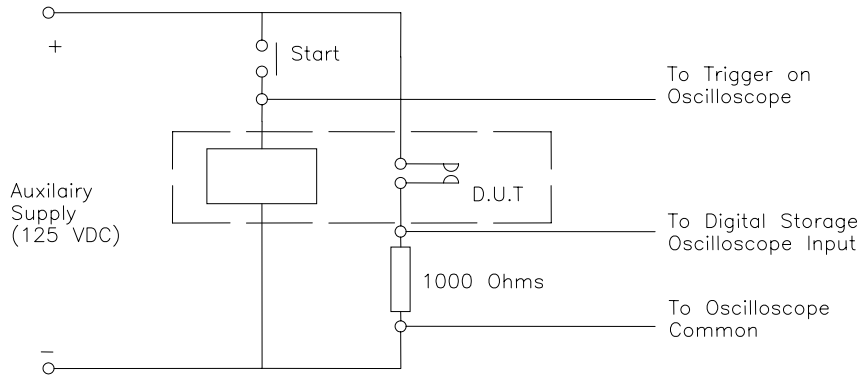

Contact Test Setup. Pictorial representation shown actual schematic contains switches and various components.

### CONTACT OPERATE WAVEFORMS

Below are the "Ideal" waveforms to indicate the difference between the N/O & N/C contacts

