

PRODUCT/TEST MANUAL

2T104K1

DIGITAL DELAY ON/DELAY OFF TIMER



Order Number

Serial Number

Issue	Date	Summary of changes
A	29/02/00	Initial issue.

Due to RMS continuous product improvement policy this information is subject to change without notice.
This document is uncontrolled and subject to copyright.

Author	Checked & Registered	.pdf file created	Released
ERL	MW	MW	

1. BROAD DESCRIPTION

The 2T104 time delay on energisation relay is particularly suitable for use in protection and control schemes where precision time delays are required.

A crystal oscillator and digital dividing circuit are employed to provide the timebase for a pre-settable down counter chain. When positive supply is applied to the control input, the down counter is loaded with the thumbwheel switch setting and begins counting down. When zero is detected, the output relay picks up and the down counter stops. The three time ranges can be selected via a front panel switch which changes the divide ratio of the timebase circuit. Front panel LED's indicate the relay status.

2. SPECIFICATIONS

INITIATE INPUT	75-150 Volts DC +/- 10% Energise initiate input to actuate timer functions
REM FLAG RESET INPUT	75-150 Volts DC +/- 10%
ACCURACY	The setting and repeat accuracy is: ±0.5% of setting (plus the inherent minimum time).
AUXILIARY SUPPLY	40 - 300 V DC Switchmode power supply
RESET TIME	Electronic reset time is between 20 and 50 millisecond. Output relay dropout time is less than 20 millisecond and removal of auxiliary supply will reset the relay in this time.
INSULATION WITHSTAND	In accordance with AS2481-1981 (clause 5-4), IEC 255-5: 2KV RMS between input and frame, output and frame, and output and input. 1.2/50 5KV impulse between each terminal and earth, between circuits not normally connected together and between terminals of the same circuit.
NOISE IMMUNITY	Withstands the high frequency interference test detailed in AS2481-1981 (clause 5-5 App. D), IEC 255-22-1.
OUTPUT CONTACTS	The output relay is fitted with four changeover contacts as standard.
OUTPUT RELAY CONTACT RATINGS	
Make and Carry Continuously	
3000 VA AC resistive with maximums of 660 Volt and 12 Amp 3000 VA DC resistive with maximums of 660 Volt and 12 Amp	
Make and Carry of 0.5 Second	
7500 VA AC resistive with maximums of 660 Volt and 30 Amp 7500 VA DC resistive with maximums of 660 Volt and 30 amp	
OPERATION INDICATOR	The standard relay has a hand resettable magnetic disc (permanent memory) indicator fitted to give visual indication that the output relay element has operated..

3. TEST EQUIPMENT REQUIRED

- DC Auxiliary Supply
- Frequency Counter
- Digital Voltmeter
- Oscilloscope
- Electronic Counter (for measuring operate times)
- High Voltage Test Equipment

4. ASSOCIATED DRAWINGS

- 164-104-101 Wiring Diagram
- 660-308-201 Circuit Diagram
- 660-308-300 Loading Diagram

5. HIGH VOLTAGE TESTING

- a) Apply 2KV RMS 50 Hz between terminal groups 1 and 2 in Table 1 for 1 minute.
- b) Apply 3 5KV 1/50us pulses of each polarity between terminal groups 1 and 2 in Table 1.

TABLE 1

Group 1	Group 2
1,3,5,7,9,10,23,25,27	11,15,12,16,19,21,20,22
1,3,9,10,11,15,12,16	5,7,23,25,27,19,21,20,22
1,3,5,7,11,15,19,21	9,10,23,25,27,12,16,20,22
All terminals	Frame

6. CALIBRATION & TEST PROCEDURE

Connect timing apparatus to measure interval between energisation of the initiate input and output relay contact closure. Set JO5 jumper N/O (Pins 1 & 2)

Note : The instantaneous operate time of the relay has to be added to the time setting thumbwheel

- b) Set range switch to range A and time to 000.
- c) Record pick-up time for auxiliary voltage of 40 V.

Maximum	Actual	Unit
50	<input style="width: 100px; height: 20px;" type="text"/>	ms

- d) Record drop-out time for auxiliary voltage of 300 V

Maximum	Actual	Unit
20	<input style="width: 100px; height: 20px;" type="text"/>	ms

- e) Record times for the following settings (range A)

Setting	Minimum	Maximum	Nominal	Actual	Unit
111	121	161	151	<input style="width: 100px; height: 20px;" type="text"/>	ms
222	232	272	262	<input style="width: 100px; height: 20px;" type="text"/>	ms
444	454	494	484	<input style="width: 100px; height: 20px;" type="text"/>	ms
888	898	938	928	<input style="width: 100px; height: 20px;" type="text"/>	ms

6. CALIBRATION & TEST PROCEDURE (Cont)

f) Set time to 100 and set range to B.

Minimum	Maximum	Nominal	Actual	Unit
1.01	1.05	1.04	<input type="text"/>	s

g) Set range switch to C and record pick-up time.

Minimum	Maximum	Nominal	Actual	Unit
10.01	10.05	10.04	<input type="text"/>	s

7. GENERAL & FUNCTIONAL

a) Check for correct operation of magnetic disc flag.

OK

b) Check that the magnetic flag can be remotely reset

OK

c) Check operation of the relay fail alarm

OK

d) Check that the relay is electrically sound and mechanically robust as per Standard Inspection & Test Schedule 903-000-026.

PASS

TESTED BY : _____ DATE : _____

8. CONNECTION DIAGRAM

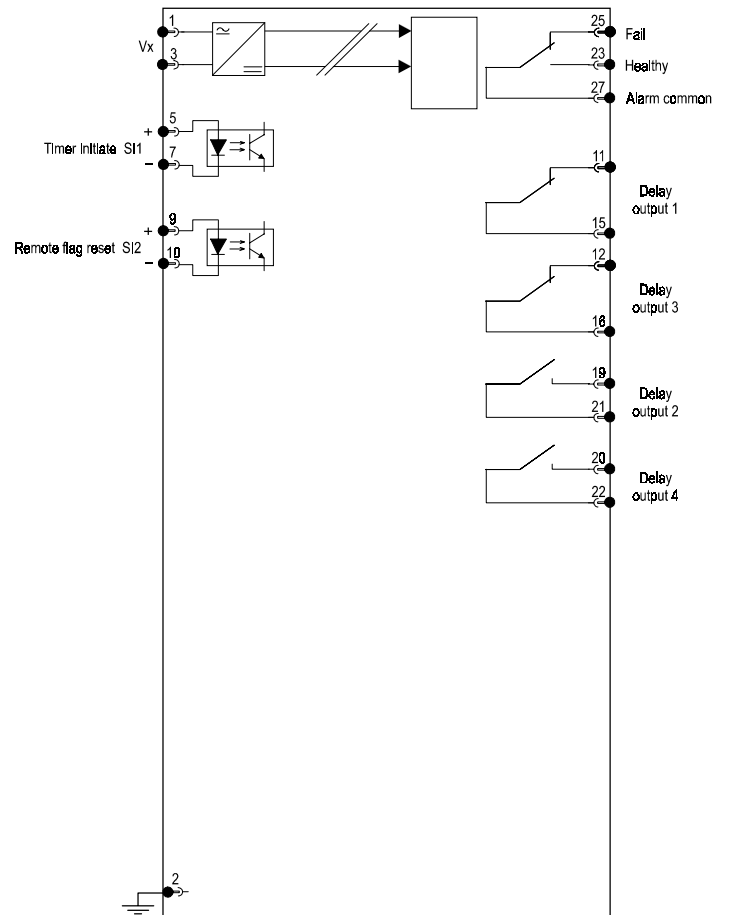

2T104 wiring diagram - Relay shown in de-energised condition