



REYROLLE

2V73 User Guide

High Impedance Differential Relay

relay monitoring systems pty ltd

Advanced Protection Devices



User Guide



Test Manual

2V73 User Guide

About This Manual

This User Guide covers all 2V73 relays manufactured from May 2003. Earlier relays do not necessarily incorporate all the features described. Our policy of continuous may means that extra features & functionality may have been added.

The 2V73 User Guide is designed as a generic document to describe the common operating parameters for all relays built on this platform. Some relay applications are described but for specific model information the individual "K" number Product / Test manuals should be consulted.

The copyright and other intellectual property rights in this document, and in any model or article produced from it (and including any Registered or unregistered design rights) are the property of Relay Monitoring Systems Pty Ltd. No part of this document shall be reproduced or modified or stored in another form, in any data retrieval system, without the permission of Relay Monitoring Systems Pty Ltd, nor shall any model or article be reproduced from this document without consent from Relay Monitoring Systems Pty Ltd.

While the information and guidance given in this document is believed to be correct, no liability shall be accepted for any loss or damage caused by any error or omission, whether such error or omission is the result of negligence or any other cause. Any and all such liability is disclaimed.

Contact Us

© Relay Monitoring Systems Pty Ltd 2001-2008
6 Anzed Court • Mulgrave 3170 • AUSTRALIA
Phone 61 3 9561 0266 • Fax 61 3 9561 0277
Email rms@rmspl.com.au • Web www.rmspl.com.au

To download a PDF version of this guide:
http://www.rmspl.com.au/userguide/2v73_user_guide.pdf

To download the model specific Test Manual:
<http://www.rmspl.com.au/search.asp>

How this guide is organised

This guide is divided into five parts:

Part 1 Overview

About this Manual

Contents

Test Manual

Part 2 Mechanical Configuration

Part 3 Technical Bulletin

Part 4 Installation

Handling of Electronic Equipment

Safety

Unpacking

Accessories

Storage & Handling

Equipment Operating Conditions

Relay Dimensions & Other Mounting Accessories

Equipment Connections

Commissioning

Decommissioning & Disposal

Part 5 Maintenance

Mechanical Inspection

Test Intervals

Test Method

Defect Report Form



Test Manual

This User Guide covers all 2V73 relay versions & describes the generic features & attributes common across all versions.

Different relay versions are required to cater for varying customer requirements such as auxiliary voltage range, I/O configuration, case style, relay functionality etc.

The product ordering code described in the Technical Bulletin is used to generate a unique version of the relay specification & is called a type number. The type number takes the form 2V73Kxx where the Kxx is the "K" or version number.

Refer to: www.rmspl.com.au/handbook/parta3.pdf
for a complete description of the RMS "K" number system.

Each 2V73 version has a specific Test Manual which provides details on the unique attributes of the relay. Each Test Manual includes the following information:

- Test Certificate
- Specific technical variations from the standard model if applicable
- Test & calibration record
- Wiring diagram

A Test Manual is provided with each relay shipped.

If you require a copy of the Test Manual for an RMS product the following options are available:

- Check the RMS web site at: www.rmspl.com.au/search.asp
- RMS CD catalogue select: [List all Product/Test Manuals](#) under [Technical Library](#)
- Contact RMS or a representative & request a hard copy or PDF by email.



Mechanical Configuration

Great care has been taken to design a rugged, cost effective & flexible mechanical solution for the *MATRIX* range of RMS protection relays. The *MATRIX* range provides a compact draw out case solution with M4 screw terminals:

- 2M28 Size 2 with 28 terminals
- 4M28 Size 4 with 28 terminals
- 4M56 Size 4 with 56 terminals

Complete details & attributes for the M (*MATRIX*) cases & accessories may be found at:

<http://www.rmspl.com.au/mseries.htm>

The 2V73 is configured in a 2M28 case & the following photographs depict the general mechanical configuration. It should be noted that re-usable screw rivets are used to bind the draw out relay module. A 1/16" hex key is required for disassembly.

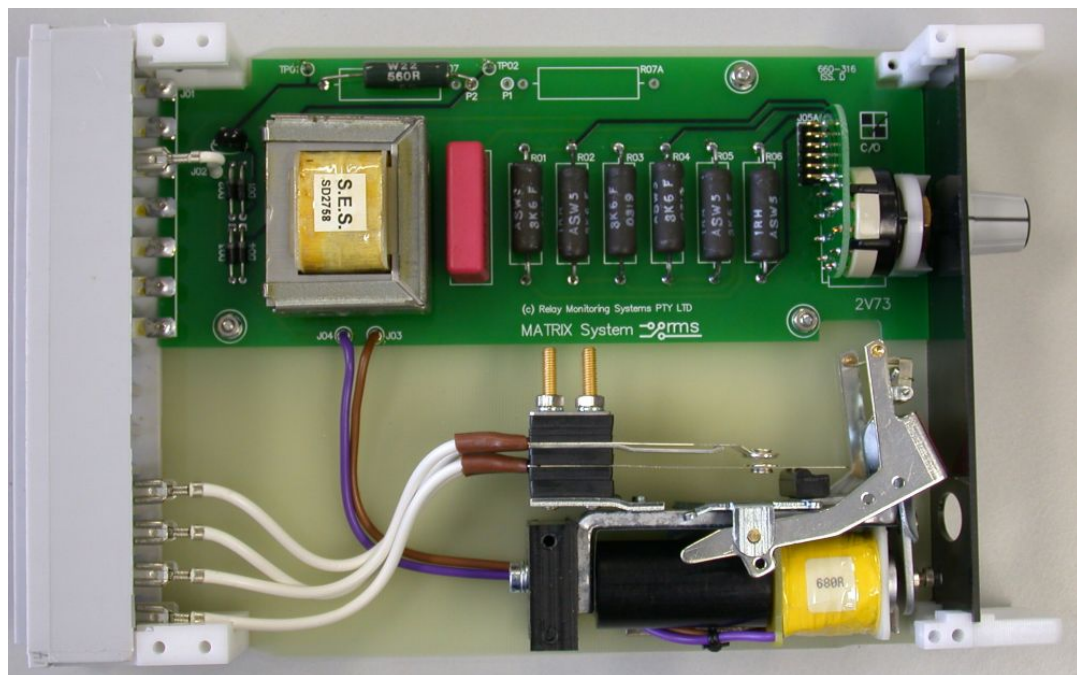

REYROLLE

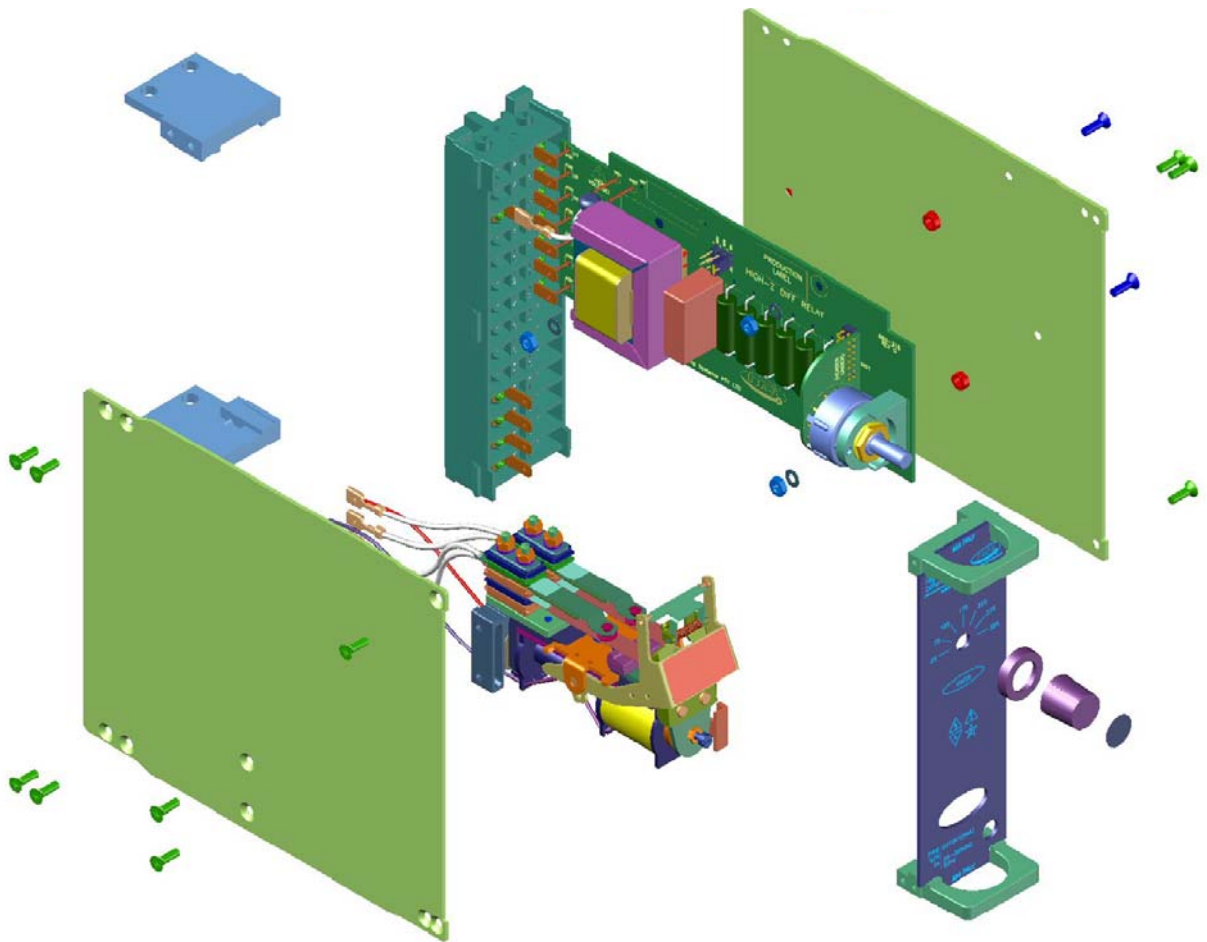

2V73 relay assembly depicted in a 2M28 case

REYROLLE



Mechanical flag option allowing local reset without auxiliary voltage – standard model



Magnetic flag option allowing remote electrical reset

Technical Bulletin

The detailed technical attributes, functional description & performance specifications for the 2V73 are described in the attached Technical Bulletin. For the most up to date version go to:

www.rmspl.com.au/handbook/2v73.htm

For any specific attributes of a particular version refer to the Test Manual for that type (K) number.

The order of precedence for technical information is as follows:

- Test Manual
- Technical Bulletin
- User Guide

Features

- High speed operation
- High sensitivity
- Wide range of settings
- High stability
- 25-115V & 25-325V versions
- 50Hz & 60Hz versions
- Insensitive to DC
- Hand reset mechanical flag
- Optional remote reset flag
- Rugged attracted armature sensing elements
- Use 3 independent units for 3 phase applications
- Size 2M draw out case

Application

The 2V73 relay provides high speed differential protection for various items of power system plant including generators, busbars, motors & the individual windings of power transformers. It is also suitable for restricted earth fault protection applications.

When circulating current protection schemes are subjected to sudden & often asymmetrical growth in system currents due to through faults, the line current transformers can quickly reach saturation. In this condition, variation in transformer magnetizing characteristics can cause large ratio errors with a consequent circuit imbalance & false tripping of the protective relay scheme.

In order to ensure protection stability, a high impedance differential relay set to operate at a slightly higher voltage than that developed in the worst case of the above condition for a through fault current may be used. On a balanced earth fault system for example, this is when one CT of a group is saturated while the others remain unaffected. The saturated CT presents a low impedance path in parallel with the relay, which effectively limits the voltage applied to avoid operation. On internal faults however, this limitation does not exist & voltages of twice the relays pick up settings are easily reached.

The 2V73 relay is a single phase device built in a compact size 2M draw out case suitable for rack and flush mounting. Where 3 phase monitoring is required, 3 single phase units should be employed.

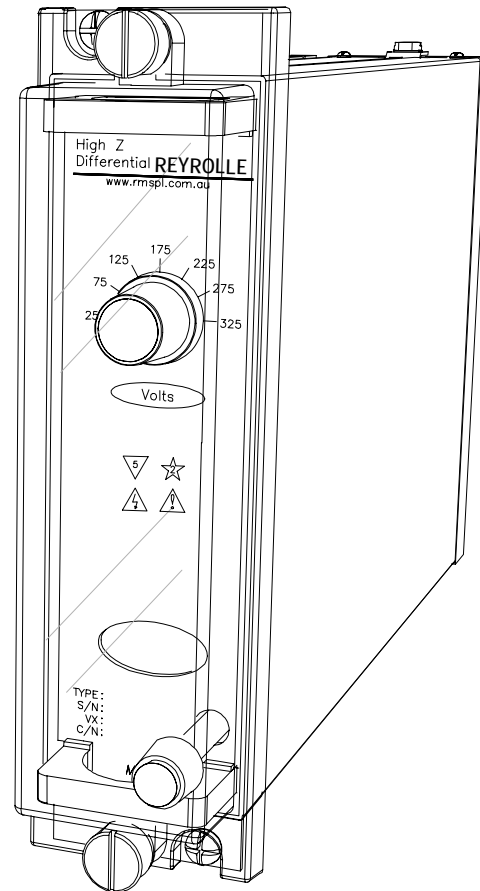

2V73 depicted in a 2M28 case

Operation

The relay measuring element is basically an attracted armature unit of simple & rugged construction powered from a bridge rectifier. The relay can be set in steps (25-115V in 15V steps or 25-325V in 50V steps), by using the front panel mounted selector switch. A capacitor is connected in series with the operating coil to make the relay insensitive to the DC component of fault current. The setting can thus be calculated in terms of RMS AC quantities without regard for the degree of offsets produced by the point on wave at which the fault occurs. An inductor connected in series with the capacitor forms a resonant circuit tuned to the relays rated frequency.

An external Metrosil unit having a non-linear resistance characteristic is required for each phase element to limit the peak voltage appearing across the secondary differential circuits under internal fault conditions. The type of Metrosil characteristic required is dependant on the relay setting range. For AC applications the following equation can be used to determine an approximate AC characteristic:

$$V = 0.84 C (I)^B$$

V = RMS voltage, I = RMS Amps, C & B are fixed constants for the selected Metrosil. For the setting range of 25 to 325V a Metrosil with nominal C = 1,000 & B = 0.22 is suitable to provide a 400V continuous rating & current overload short time rating as follows: 15A for 3s, 21A for 2s & 37A for 1s.

RELATED EQUIPMENT

- ◆ Refer to the 2V75 Fact Sheet for details on the RMS Metrosil modules;
- ◆ Refer to the 1M123 & 1M124 Fact Sheet for details on complete BUS protection rack solutions;
- ◆ Refer to the 2V68 Fact Sheet for details on CT supervision applications;
- ◆ The 2V73 is a voltage operated relay. For a current operated version refer to the 2C73 Fact Sheet.



DERIVED RELAY POWER

During internal fault conditions, the relay & Metrosil current & the magnetizing current of all the connected CT's is supplied from the fault current.

EFFECTIVE OPERATING CURRENT

The primary operating current is given by: $I_{op} = n (I_R + N I_O)$

I_R = Relay operating current & Metrosil current at setting voltage as per the table below.

I_O = CT magnetizing current at setting voltage (A)

n = CT turns ratio

N = Number of connected CT's

The operating currents shown in the following tables are for both 3 inch & 6 inch Metrosil's connected to the 2V73 as per the wiring diagram.

Range A (Volts)	25	75	125	175	225	275	325
Nominal (mA)	15	15	15	15	17	21	29
Limits (mA)	13	13	13	13	13	15	18
	to	to	to	to	to	to	to
	16	17	17	20	27	39	61

Range B (Volts)	25	40	55	70	85	100	115
Nominal (mA)	14	14	14	14	14	14	14
Limits (mA)	13	13	13	13	13	13	13
	to	to	to	to	to	to	to
	16	16	16	17	17	17	17

Should the natural effective operating current after applying the above formula be lower than desired, it can be raised to the required level by adding a shunt resistor across the differential relay input circuit.

SELECTION OF OPTIMUM RELAY SETTING

The required relay setting (V_s) is calculated using the following formula:

$$V_s = \frac{I_f}{n} (R_{ct} + 2 R_w) \text{ Volts}$$

I_f = Max. primary through fault current for which stability is required (RMS Amps)

n = CT turns ratio

R_{ct} = CT secondary winding resistance (Ohms)

R_w = Resistance of each lead between the relay & CT (Ohms)

A value of V_s is calculated for each CT circuit in the differential system, & the relay setting finally chosen above the highest of these calculated values.

RECOMMENDED METROSIL's (Refer 2V75 Fact Sheet)

Type	Specification	Rated Energy	Part No.
6" 3 ϕ	600A/S3/I/S887	33kJ	2105C58001
6" 1 ϕ	600A/S1/S887	33kJ	2105C58002
3" 3 ϕ	300A/S3/I/S3063	8kJ	2105C58006
3" 1 ϕ	300A/S1/S646	8kJ	2105C58004

CURRENT TRANSFORMERS (CT's)

The 2V73 type relay is suitable for use with 0.5A, 1A & 5A CT's at 50 or 60Hz. The CT's used in circulating current differential protection systems must be of equal turns ratio & have a reasonably low secondary winding resistance. The CT knee point voltage (Point on magnetization curve at which a 10% increase in excitation voltage produces a 50% increase in excitation current) should be at least twice the voltage setting.

REYROLLE

SETTING RANGE

25-325V AC in 50V steps
25-115V AC in 15V steps

FREQUENCY

Specify 50Hz or 60Hz operation

OUTPUT RELAY OPERATION INDICATOR

Hand reset mechanical indicator.

REMOTE RESET FLAG OPTION

No auxiliary is required when the hand reset mechanical flag is specified. To facilitate remote flag resetting, a magnetic type flag may be specified which requires a separate auxiliary for the flag to set & reset to function. This auxiliary is low burden & must be continuously applied to the flag auxiliary input.

Magnetic flag reset operating range:

Specify: 24 to 150V DC or
140 to 300 V DC

PICK UP ACCURACY

+/-10% of setting & +/-3V on the 25V setting.

OUTPUT RELAY CONTACTS

2 N/O

OPERATE TIMES

Pick up: <20ms at 4 times V_s
Drop out: <50ms

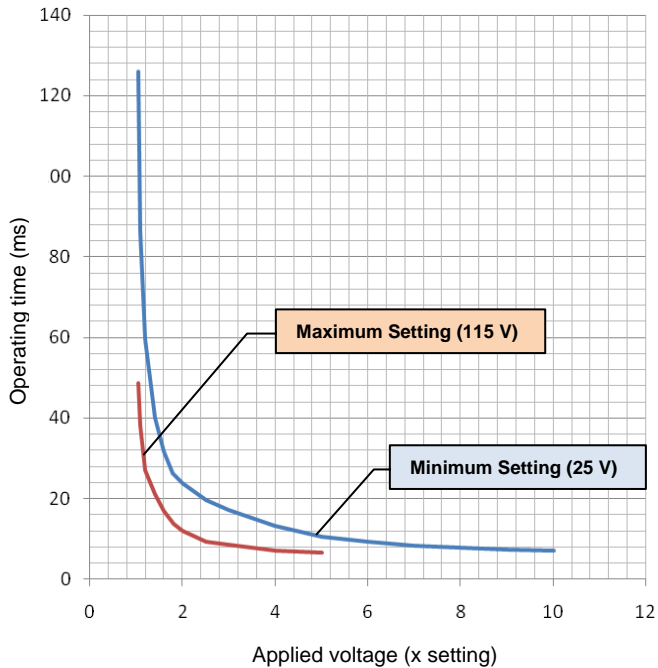

Figure 1 – 2V73 Operating Characteristic

Technical Data

THERMAL WITHSTAND – RELAY ALONE

Range	Continuous	1s
25-175V	2 x setting	8x setting
25-325V	1.5 x setting	6x setting

6R RELAY CONTACT RATINGS

Make & Carry Continuously

3,000 VA AC resistive with maximums of 660V & 12A
3,000 W DC resistive with maximums of 660V & 12A

Make & Carry for 0.5 Seconds

7,500 VA AC resistive with maximums of 660V & 30A
7,500 W DC resistive with maximums of 660V & 30A

AC Break Capacity

3,000 VA AC resistive with maximums of 660V & 12A

DC Break Capacity (Amps)

Voltage		24V	48V	125V	250V
Resistive rating		12	1.5	0.5	0.25
L/R=40ms	Maximum break *	12	1	0.25	0.15

TRANSIENT OVERVOLTAGE

Between all terminals & earth
Between independent circuits without damage or flashover

IEC60255-5 CLASS III

5kV 1.2/50us 0.5J
5kV 1.2/50us 0.5J

INSULATION COORDINATION

Between all terminals & earth
Between independent circuits
Across normally open contacts

IEC60255-5 CLASS III

2.0kV RMS for 1 minute
2.0kV RMS for 1 minute
1.0kV RMS for 1 minute

HIGH FREQUENCY DISTURBANCE

2.5kV 1MHz common mode
1.0kV 1MHz differential mode

IEC60255-22-1 CLASS III

≤ 3% variation

ELECTROSTATIC DISCHARGE

6kV contact discharge

IEC60255-22-2 CLASS III

≤ 5% variation

RADIO FREQUENCY INTERFERENCE

10V/m, 80 TO 1,000MHz

IEC60255-22-3

≤ 5% variation

FAST TRANSIENT

4kV, 5/50ns, 2.5KHz repetitive

IEC60255-22-4

≤ 3% variation

CONDUCTED RFI

10V, 0.15 to 80MHz

IEC60255-22-6

≤ 5% variation

TEMPERATURE RANGE

Operating:
Storage:

IEC68-2-1/2

-5 to +55°C
-25 to +75°C



High impedance differential protection application
(Use 3 units for 3 phase configuration)

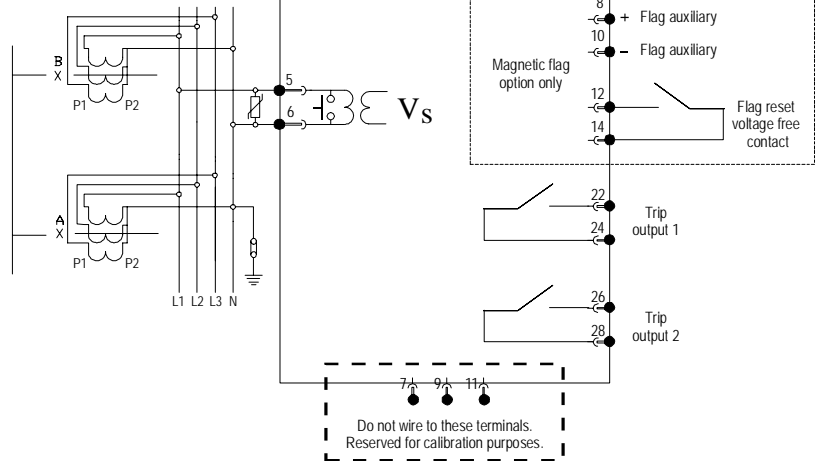

Restricted earth fault application

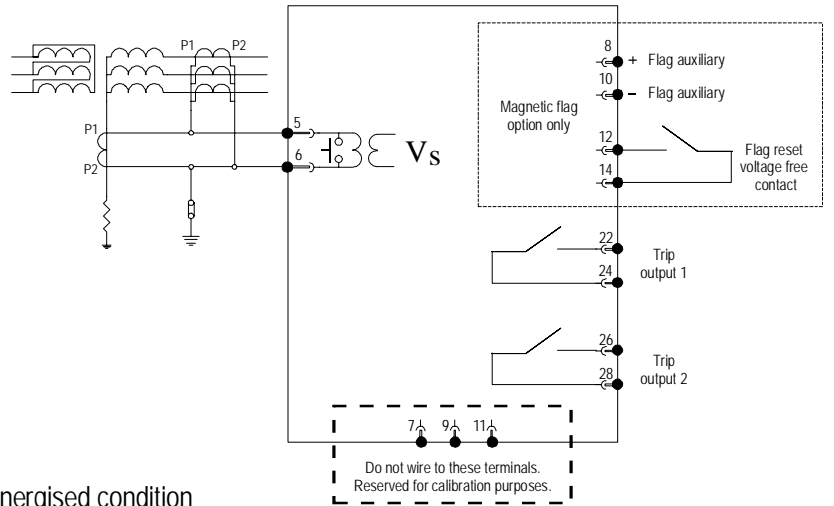

2V73 wiring diagrams - Relay shown in de-energised condition

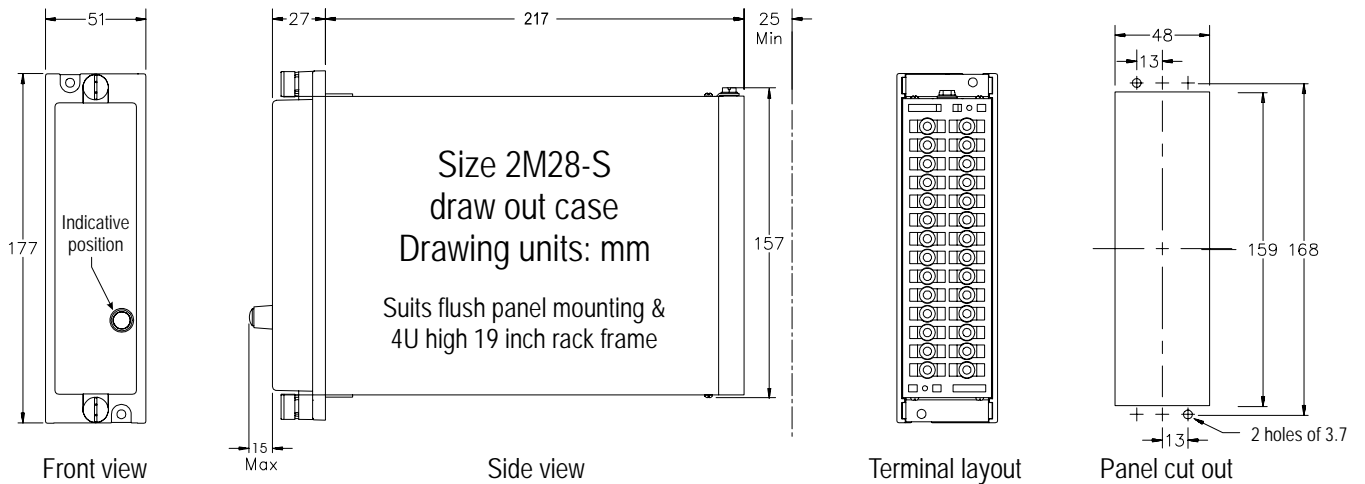

CERTIFIED QUALITY
MANAGEMENT SYSTEM
ISO 9001

REYROLLE

CASE

Size 2M28-S draw out case

28 M4 screw terminals

Flush panel mount or 4U high 1/8 width 19 inch rack mount

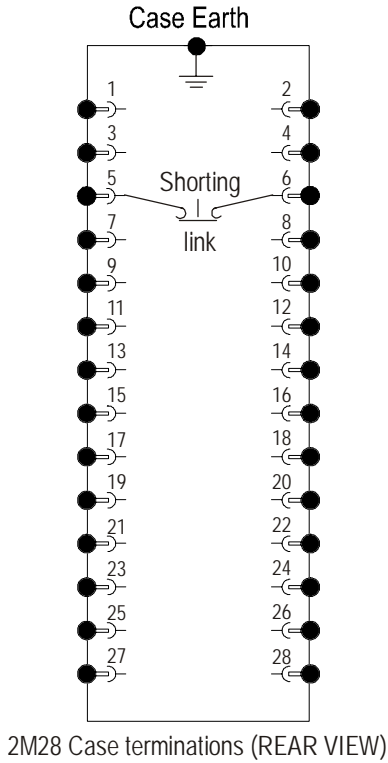

Ordering Information

Generate the required ordering code as follows: e.g. 2V73 BAA

General Type	Order Code		
	1	2	3
2V73			

1 SETTING RANGE

- A 25-325V AC in 50V steps
- B 25-115V AC in 15V steps

2 RATED FREQUENCY

- A 50 Hz
- B 60 Hz

3 FLAG TRIP INDICATION

- A Mechanical flag – no flag auxiliary required
- B Magnetic flag – 24 to 150V DC auxiliary
- C Magnetic flag – 140 to 300 V DC auxiliary

Installation

Handling of Electronic Equipment

A person's normal movements can easily generate electrostatic potentials of several thousand volts. Discharge of these voltages into semiconductor devices when handling electronic circuits can cause serious damage, which often may not be immediately apparent but the reliability of the circuit will have been reduced.

The electronic circuits of Relay Monitoring Systems Pty Ltd products are immune to the relevant levels of electrostatic discharge when housed in the case. Do not expose them to the risk of damage by withdrawing modules unnecessarily.

Each module incorporates the highest practicable protection for its semiconductor devices. However, if it becomes necessary to withdraw a module, the following precautions should be taken to preserve the high reliability and long life for which the equipment has been designed and manufactured.

1. Before removing a module, ensure that you are at the same electrostatic potential as the equipment by touching the case.
2. Handle the module by its front-plate, frame, or edges of the printed circuit board.
3. Avoid touching the electronic components, printed circuit track or connectors.
4. Do not pass the module to any person without first ensuring that you are both at the same electrostatic potential. Shaking hands achieves equipotential.
5. Place the module on an antistatic surface, or on a conducting surface which is at the same potential as yourself.
6. Store or transport the module in a conductive bag.

If you are making measurements on the internal electronic circuitry of an equipment in service, it is preferable that you are earthed to the case with a conductive wrist strap.

Wrist straps should have a resistance to ground between 500k – 10M ohms. If a wrist strap is not available, you should maintain regular contact with the case to prevent the build up of static.

Instrumentation which may be used for making measurements should be earthed to the case whenever possible.

REYROLLE

Safety Section

This Safety Section should be read before commencing any work on the equipment.

The information in the Safety Section of the product documentation is intended to ensure that products are properly installed and handled in order to maintain them in a safe condition. It is assumed that everyone who will be associated with the equipment will be familiar with the contents of the Safety Section.

Explanation of Symbols & Labels

The meaning of symbols and labels which may be used on the equipment or in the product documentation, is given below.

Caution: refer to product information



Caution: risk of electric shock

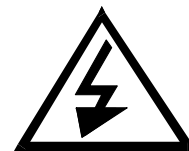

Functional earth terminal

Note: this symbol may also be used for a protective/safety earth terminal if that terminal is part of a terminal block or sub-assembly eg. power supply.

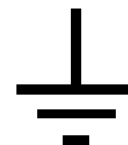

REYROLLE

Unpacking

Upon receipt inspect the outer shipping carton or pallet for obvious damage.

Remove the individually packaged relays and inspect the cartons for obvious damage.

To prevent the possible ingress of dirt the carton should not be opened until the relay is to be used. Refer to the following images for unpacking the relay:



Outer packing carton showing shipping documentation pouch.
Address label on top of carton.



Inner packing carton showing front label detailing the customer name, order number, relay part number & description, the relay job number & packing date. (Size 2 inner packing carton depicted)

REYROLLE

Unpacking (Continued)



Inner packing carton with lid open showing protective foam insert.

CD depicted supplied with digital relay models or upon request at time of order.



Inner packing carton with protective foam insert removed showing relay location.



Where mechanical flags are fitted the yellow transit wedge must be removed before operation using a gentle twisting action. The wedge should be stored with the original packaging material.

REYROLLE

Relay Module Side Label Depicting Product Details



Relay Module Side Label Depicting Wiring Diagram (6R MATRIX relays only)

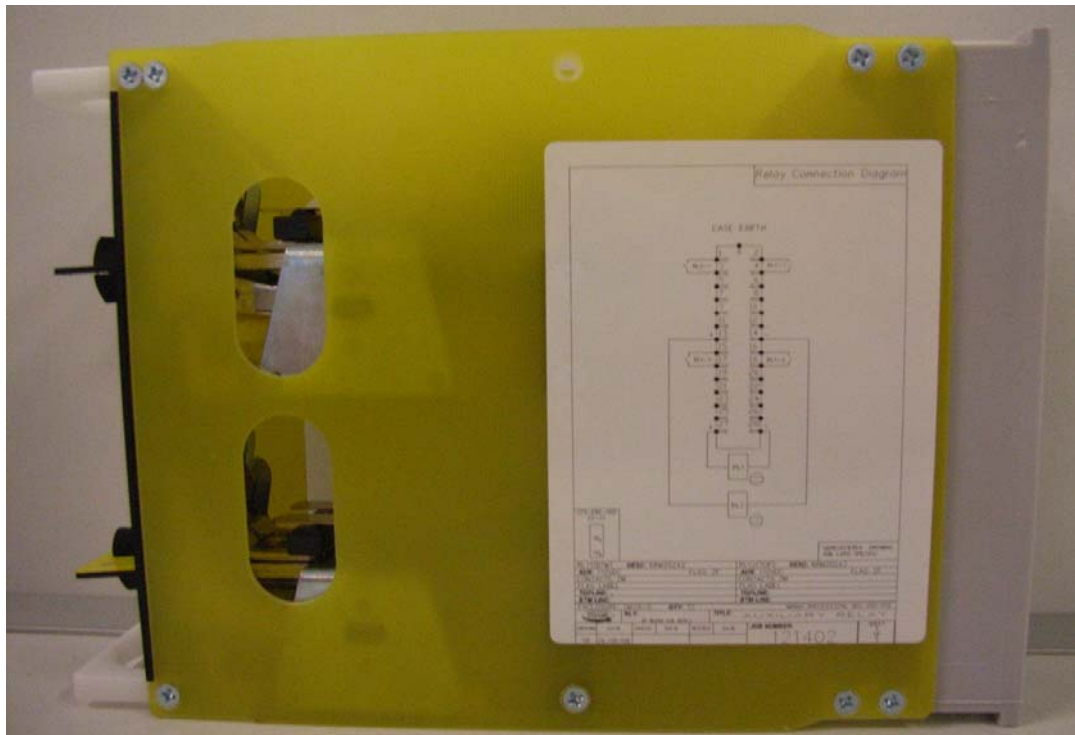

REYROLLE

Accessories Supplied With Each Relay



Self threading M4 mounting screws



M4 terminal screws with captured lock washers

Storage & Handling

If damage has been sustained a claim should immediately be made against the carrier, also inform Relay Monitoring Systems Pty Ltd and the nearest RMS agent

When not required for immediate use, the relay should be returned to its original carton and stored in a clean, dry place.

Relays which have been removed from their cases should not be left in situations where they are exposed to dust or damp. This particularly applies to installations which are being carried out at the same time as constructional work.

If relays are not installed immediately upon receipt they should be stored in a place free from dust and moisture in their original cartons.

Dust which collects on a carton may, on subsequent unpacking, find its way into the relay; in damp conditions the carton and packing may become impregnated with moisture and the de-humidifying agent will lose its efficiency.

REYROLLE

Equipment Operating Conditions

The equipment should be operated within the specified electrical and environmental limits.

Protective relays, although generally of robust construction, require careful treatment prior to installation and a wise selection of site. By observing a few simple rules the possibility of premature failure is eliminated and a high degree of performance can be expected.

Care must be taken when unpacking and installing the relays so that none of the parts are damaged or their settings altered and must at all times be handled by skilled persons only.

Relays should be examined for any wedges, clamps, or rubber bands necessary to secure moving parts to prevent damage during transit and these should be removed after installation and before commissioning.

The relay should be mounted on the circuit breaker or panel to allow the operator the best access to the relay functions.

Relay Dimensions & Other Mounting Accessories

Refer drawing in Technical Bulletin. Relevant Auto Cad files & details on other accessories such as 19 inch sub rack frames, semi projection mount kits & stud terminal kits may be down loaded from:

<http://www.rmspl.com.au/mseries.htm>

REYROLLE

Equipment Connections

Personnel undertaking installation, commissioning or servicing work on this equipment should be aware of the correct working procedures to ensure safety. The product documentation should be consulted before installing, commissioning or servicing the equipment.

Terminals exposed during installation, commissioning and maintenance may present hazardous voltage unless the equipment is electrically isolated.

If there is unlocked access to the rear of the equipment, care should be taken by all personnel to avoid electric shock or energy hazards.

Voltage and current connections should be made using insulated crimp terminations to ensure that terminal block insulation requirements are maintained for safety. To ensure that wires are correctly terminated, the correct crimp terminal and tool for the wire size should be used.

Before energising the equipment it must be earthed using the protective earth terminal, or the appropriate termination of the supply plug in the case of plug connected equipment. Omitting or disconnecting the equipment earth may cause a safety hazard.

The recommended minimum earth wire size is 2.5mm², unless otherwise stated in the technical data section of the product documentation.

Before energising the equipment, the following should be checked:

1. Voltage rating and polarity;
2. CT circuit rating and integrity of connections;
3. Protective fuse rating;
4. Integrity of earth connection (where applicable)

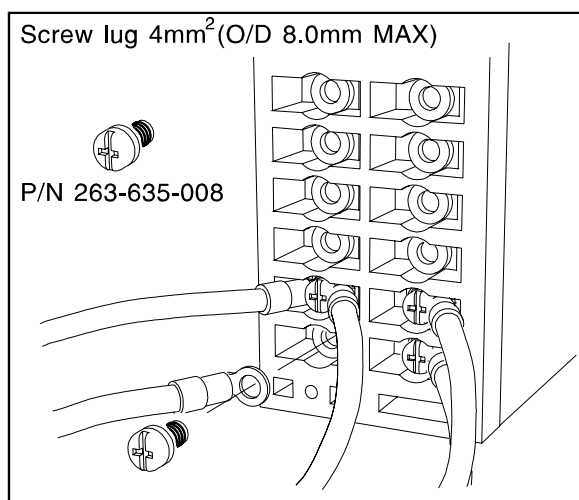

REYROLLE

Current Transformer Circuits

Do not open the secondary circuit of a live CT since the high voltage produced may be lethal to personnel and could damage insulation.

External Resistors

Where external resistors are fitted to relays, these may present a risk of electric shock or burns, if touched.

Insulation & Dielectric Strength Testing

Insulation testing may leave capacitors charged up to a hazardous voltage. At the end of each part of the test, the voltage should be gradually reduced to zero, to discharge capacitors, before the test leads are disconnected.

Insertion of Modules

These must not be inserted into or withdrawn from equipment whilst it is energised, since this may result in damage.

Electrical Adjustments

Pieces of equipment which require direct physical adjustments to their operating mechanism to change current or voltage settings, should have the electrical power removed before making the change, to avoid any risk of electric shock.

Mechanical Adjustments

The electrical power to the relay contacts should be removed before checking any mechanical settings, to avoid any risk of electric shock.

Draw Out Case Relays

Removal of the cover on equipment incorporating electromechanical operating elements, may expose hazardous live parts such as relay contacts.

Insertion & Withdrawal of Heavy Current Test Plugs

When using a heavy current test plug, CT shorting links must be in place before insertion or removal, to avoid potentially lethal voltages.

REYROLLE

Commissioning Preliminaries

Carefully examine the module and case to see that no damage has occurred during transit. Check that the relay serial number on the module, case and cover are identical, and that the model number and rating information are correct.

Carefully remove any elastic bands/packing fitting for transportation purposes.

Check that the external wiring is correct to the relevant relay diagram or scheme diagram. The relay diagram number appears inside the case.

Particular attention should be paid to the correct wiring and value of any external resistors indicated on the wiring diagram/relay rating information.

Note that shorting switches shown on the relay diagram are fitted internally across the relevant case terminals and close when the module is withdrawn. It is essential that such switches are fitted across all CT circuits.

If a test block system is to be employed, the connections should be checked to the scheme diagram, particularly that the supply connections are to the 'live' side of the test block.

Earthing

Ensure that the case earthing connection above the rear terminal block, is used to connect the relay to a local earth bar.

Insulation

The relay, and its associated wiring, may be insulation tested between:

- all electrically isolated circuits
- all circuits and earth

An electronic or brushless insulation tester should be used, having a dc voltage not exceeding 1000V. Accessible terminals of the same circuit should first be strapped together. Deliberate circuit earthing links, removed for the tests, subsequently must be replaced.

REYROLLE

Commissioning Tests

If the relay is wired through a test block it is recommended that all secondary injection tests should be carried out using this block.

Ensure that the main system current transformers are shorted before isolating the relay from the current transformers in preparation for secondary injection tests.

DANGER

DO NOT OPEN CIRCUIT THE SECONDARY CIRCUIT OF A CURRENT TRANSFORMER SINCE THE HIGH VOLTAGE PRODUCED MAY BE LETHAL AND COULD DAMAGE INSULATION.

It is assumed that the initial preliminary checks have been carried out.

Relay CT shorting switches

With the relay removed from its case, check electrically that the CT shorting switch is closed.

Primary injection testings

It is essential that primary injection testing is carried out to prove the correct polarity of current transformers.

Before commencing any primary injection testing it is essential to ensure that the circuit is dead, isolated from the remainder of the system and that only those earth connections associated with the primary test equipment are in position.

Decommissioning & Disposal

Decommissioning: The auxiliary supply circuit in the relay may include capacitors across the supply or to earth. To avoid electric shock or energy hazards, after completely isolating the supplies to the relay (both poles of any dc supply), the capacitors should be safely discharged via the external terminals prior to decommissioning.

Disposal: It is recommended that incineration and disposal to water courses is avoided. The product should be disposed of in a safe manner.

Maintenance

Mechanical Inspection

Relay Assembly

Inspect the relay for obvious signs of damage or ingress of moisture or other contamination.

Relay Module

Isolate the relay, remove the front cover & carefully withdraw the relay module from the case.

Care must be taken to avoid subjecting the relay element to static discharge which may damage or degrade sensitive electronic components.

Inspect the relay module for signs of any overheating or burn marks which may have been caused by overvoltage surge or transient conditions on the power supply or digital status inputs.

Inspect the VT & CT stages for degradation of insulation on the terminal wiring & transformer windings.



Remove cover by unscrewing black thumb screws & withdraw the relay module from the case.



CERTIFIED QUALITY
MANAGEMENT SYSTEM
1503001

Due to RMS continuous product improvement policy this information is subject to change without notice. 2V73_User_Guide-5/Iss E/30/10/08

REYROLLE

Relay Case

Inspect the outer terminals checking insulation integrity & tightness.

Inspect inside the case and use a blower to remove dust.

Inspect the inner terminals for worn, distorted or tarnished contacts and if necessary clean the contacts using a brush dipped in a suitable substance.



Outer case terminal block showing CT shorting link across terminal 5-6.

Test Intervals

The maintenance tests required will largely depend upon experience and site conditions, but as a general rule it is recommended that the following inspection and tests are performed every twelve months.

- ◆ Mechanical Inspection
- ◆ Check of Connections
- ◆ Insulation Resistance Test
- ◆ Fault Setting Tests by Secondary Injection
- ◆ Tests using Load Current
- ◆ Check the continuity of the neutral CT loop with a bell test set or an ohmmeter



CERTIFIED QUALITY
MANAGEMENT SYSTEM
— 1 5 0 9 0 0 1 —

Due to RMS continuous product improvement policy this information is subject to change without notice. 2V73_User_Guide-5/lss E/30/10/08

REYROLLE

Test Method

The following method is used to determine the actual pickup of the 2V73 relay:

1. A ramp rate of 40 volts per second is used to bring the voltage to within approximately 5 volts of setting, then the rate is changed to 0.4 Volts per second until the relay picks up.
2. The closure of 2V73 contacts stops the ramping and the actual pick up voltage can be read from the display.
3. This procedure is repeated for each range setting of the 2V73.

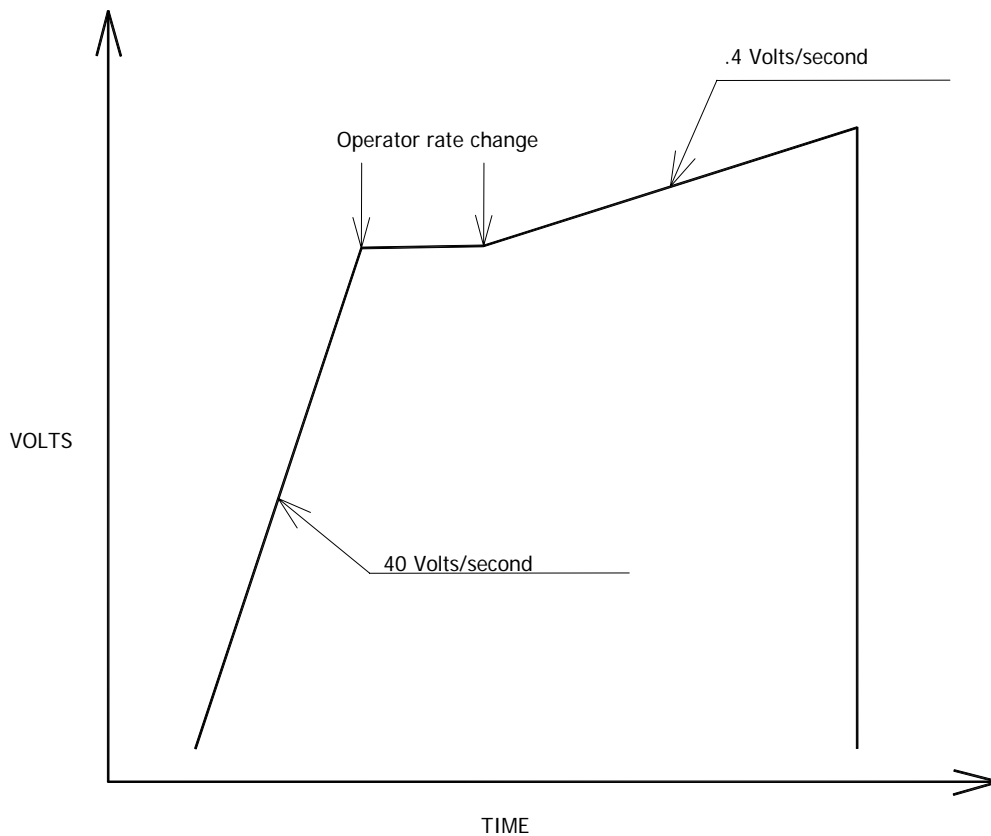

CERTIFIED QUALITY
MANAGEMENT SYSTEM
ISO 9001

Due to RMS continuous product improvement policy this information is subject to change without notice. 2V73_User_Guide-5/lss E/30/10/08

REYROLLE

Defect Report Form

Please copy this sheet and use it to report any defect which may occur.

Customers Name & Address:	Contact Name:
	Telephone No:
	Fax No:
Supplied by:	Date when installed:
Site:	Circuit:

When Defect Found

Date:	Commissioning?	Maintenance?	Systems Fault?	Other, Please State:
Product Part No:			Serial Number:	
Copy any message displayed by the relay:				
Describe Defect:				
Describe any other action taken:				
Signature:		Please Print Name:		Date:

For RMS use only

Date Received:	Contact Name:	Reference No:	Date Acknowledged:	Date of Reply:	Date Cleared:
----------------	---------------	---------------	--------------------	----------------	---------------

