



# 3A300 User Guide

## About This Manual

---

This User Guide covers all 3A300 relays manufactured from May 2004. Earlier relays do not necessarily incorporate all the features described. Our policy of continuous may means that extra features & functionality may have been added.

The 3A300 User Guide is designed as a generic document to describe the common operating parameters for all relays built on this platform. Some relay applications are described but for specific model information the individual “K” number Product / Test manuals should be consulted.

The copyright and other intellectual property rights in this document, and in any model or article produced from it (and including any Registered or unregistered design rights) are the property of Relay Monitoring Systems Pty Ltd. No part of this document shall be reproduced or modified or stored in another form, in any data retrieval system, without the permission of Relay Monitoring Systems Pty Ltd, nor shall any model or article be reproduced from this document without consent from Relay Monitoring Systems Pty Ltd.

While the information and guidance given in this document is believed to be correct, no liability shall be accepted for any loss or damage caused by any error or omission, whether such error or omission is the result of negligence or any other cause. Any and all such liability is disclaimed.

## Contact Us

---

© Relay Monitoring Systems Pty Ltd 2003-2004  
6 Anzed Court • Mulgrave 3170 • AUSTRALIA  
Phone 61 3 9561 0266 • Fax 61 3 9561 0277  
Email [rms@rmspl.com.au](mailto:rms@rmspl.com.au) • Web [www.rmspl.com.au](http://www.rmspl.com.au)

To download a PDF version of this guide:  
[http://www.rmspl.com.au/userguide/3A300\\_user\\_guide.pdf](http://www.rmspl.com.au/userguide/3A300_user_guide.pdf)

To download the model specific Test Manual:  
<http://www.rmspl.com.au/search.asp>

# How this guide is organised

---

*This guide is divided into five parts:*

---

## Part 1 Overview

About this Manual

Contents

Test Manual

Mechanical Configuration

---

## Part 2 Technical Bulletin

---

## Part 3 Description of Operation

Supervision Modes

Intertrip Function

Intertrip Event Operate Times

---

## Part 4 Installation

Handling of Electronic Equipment

Safety

Unpacking

Accessories

Storage & Handling

Recommended Mounting Position

Relay Dimensions & Other Mounting Accessories

Equipment Connections

Commissioning

---

## Part 5 Maintenance

Mechanical Inspection

Test Intervals

Defect Report Form

---



CERTIFIED QUALITY  
MANAGEMENT SYSTEM  
— ISO 9001 —

Due to RMS continuous product improvement policy this information is subject to change without notice. 3A300\_Guide\_Reyrolle Iss/E/31/05/06

## Test Manual

This User Guide covers all 3A300 relay versions & describes the generic features & attributes common across all versions.

Different relay versions are required to cater for varying customer requirements such as auxiliary voltage range, I/O configuration, case style, relay functionality etc.

The product ordering code described in the Technical Bulletin is used to generate a unique version of the relay specification & is called a type number. The type number takes the form 3A300Kxx where the Kxx is the “K” or version number.

Refer to: [www.rmspl.com.au/handbook/PARTA3.pdf](http://www.rmspl.com.au/handbook/PARTA3.pdf)  
for a complete description of the RMS “K” number system.

Each 3A300 version has a specific Test Manual which provides details on the unique attributes of the relay. Each Test Manual includes the following information:

- Test Certificate
- Specific technical variations from the standard model if applicable
- Test & calibration record
- Wiring diagram

A Test Manual is provided with each relay shipped.

If you require a copy of the Test Manual for an RMS product the following options are available:

- Check the RMS web site at: [www.rmspl.com.au/search.asp](http://www.rmspl.com.au/search.asp)
- RMS CD catalogue select: [List all Product/Test Manuals](#) under [Technical Library](#)
- Contact RMS or a representative & request a hard copy or PDF by email.



# REYROLLE

## Mechanical Configuration

Great care has been taken to design a rugged, cost effective & flexible mechanical solution for the 3A300 DC Intertrip system. The 3A300 is housed in a fully insulated case to ensure a high degree of isolation between the pilot circuit & all other connection.

The following photographs depict the general mechanical configuration:



3A300 15KV isolation version rear view showing terminal layout.



CERTIFIED QUALITY  
MANAGEMENT SYSTEM  
ISO 9001

# REYROLLE

## Mechanical Configuration



3A300 top view with cover removed showing the connection between the blue pilot wire side PCB and the isolated side PCB using optical fibre links & isolating transformer (Bottom right).

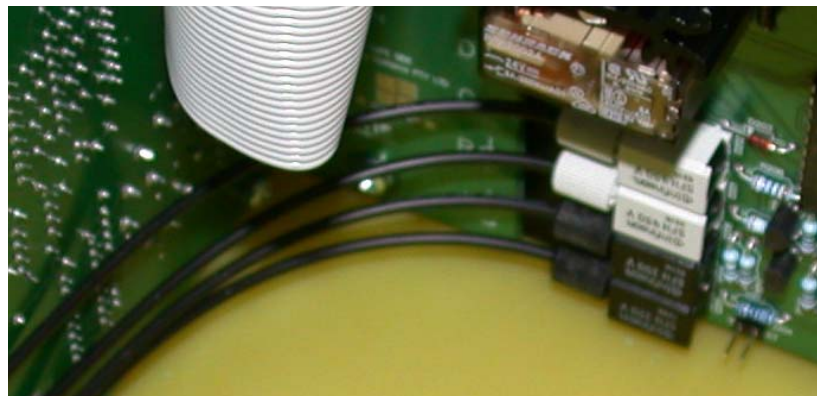

Close up of 4x optical fibre communication links between the pilot wire side PCB & isolated PCB.



CERTIFIED QUALITY  
MANAGEMENT SYSTEM  
ISO 9001

Due to RMS continuous product improvement policy this information is subject to change without notice. 3A300\_Guide\_Reyrolle Iss/E/31/05/06

## Technical Bulletin

The detailed technical attributes, functional description & performance specifications for the 3A300 are described in the attached Technical Bulletin. For the most up to date version go to:

[www.rmspl.com.au/handbook/3A300.htm](http://www.rmspl.com.au/handbook/3A300.htm)

For any specific attributes of a particular version refer to the Test Manual for that type (K) number.

The order of precedence for technical information is as follows:

- Test Manual
- Technical Bulletin
- User Guide



### Features

- Bi-direction group intertripping of up to four (4) stations (sites)
- Operates using conventional metallic pilot wires  
0 to 2K ohm pilot resistance  
0 to 2uF pilot capacitance
- Inherent 5KV or 15KV isolation  
No external components required
- Integrated pilot wire supervision system to identify location of pilot faults
- Extensive self supervision features to ensure tripping integrity
- Integrated trip circuit supply supervision
- Simple to set up & commission
- Flush, rack or projection mounting
- M4 screws for control wiring
- M5 studs for pilot cable connection with clear protective isolation cover

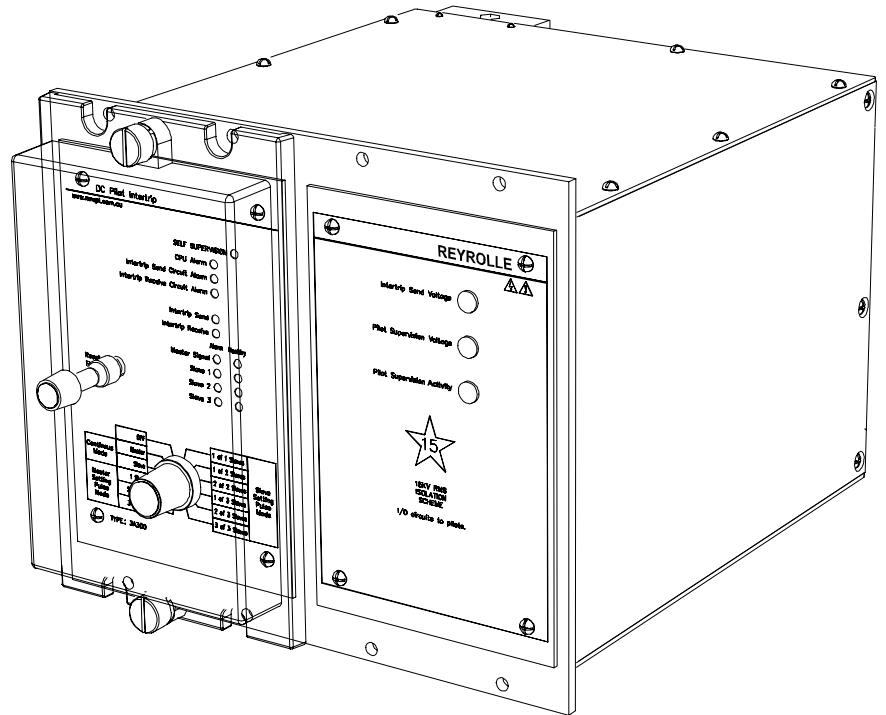

3A300 DC Supervision Station Front Panel  
15KV isolation level size 8 case version depicted

### Application

Intertripping over copper pilots using a DC signal is commonly used where these pilots are already installed. While very reliable, traditional DC intertrip systems which provide a fully supervised two ended intertrip scheme with 15KV isolation are bulky & expensive.

The 3A300 has been designed to integrate a complete scheme allowing bi-directional group intertripping of up to four remotely connected sites. Inherent 5KV or 15KV isolation allows application on electrical networks where large induced voltages may be experienced on the pilots.

Figure 1 depicts a number of typical applications where group intertripping may be applied using the 3A300 system.

System reliability is provided by the extensive built in supervision facilities. Security is achieved through the high isolation & AC immunity of the intertrip receive elements.

The efficient compact design of the 3A300 makes it suitable for surface or panel mounting & allows the use of standard sub station batteries.

### Description

Each 3A300 station comprises the following functional elements:

- ◆ Intertrip send input which is interfaced to the local protection trip contact;
- ◆ Intertrip receive output contact which is interfaced to the local breaker;
- ◆ Isolated DC intertrip voltage for application to pilot wire as required;
- ◆ Pilot wire supervision system to monitor the pilot wire integrity;
- ◆ Trip voltage supply input to provide local trip circuit supply supervision;
- ◆ Self supervision circuitry to monitor & alarm in event of system failure;
- ◆ A control panel for setting & displaying the system status.

#### Intertripping

Intertripping is achieved by application of a DC signal onto the pilot for 2s at the send end. An intertrip can be initiated at any 3A300 station & all other 3A300 stations will respond by closing their trip receive contacts.

#### Pilot Wire Supervision

When activated, pilot wire supervision is based on a lower DC signal that is monitored by all stations & an alarm initiated in the event of a fault. Two modes (Continuous & pulse), may be selected.

#### AC Immunity

AC filtering is employed on the intertrip receive & supervision receive elements to provide immunity to AC voltages which may be induced on the pilot & otherwise cause mal operation.

#### Pilot Wire Isolation

5KV or 15KV power supply isolation is provided using a compact encapsulated isolating transformer utilizing triple insulated Teflon winding wire. The intertrip & pilot wire supervision send & receive channels are isolated using fibre optic links.

# REYROLLE

## SYSTEM OPERATION

The 3A300 uses a DC/DC converter to generate a regulated DC intertrip voltage. This voltage is maintained on the isolated side of the circuit & is switched onto the pilot lines when an intertrip send command is applied.

A DC intertrip receive element is incorporated which will operate down to a tripping threshold of 70V DC providing adequate head room for voltage losses on the pilots & up to three other 3A300 stations on the same circuit.

When an intertrip send signal is applied to any 3A300 station, remote tripping at all other stations is effected.

- Intertrip Send ●
- Intertrip Receive ●

Refer to the typical applications shown in figure 2 & the functional block diagram depicted in figure 6.

## PILOT WIRE CONNECTION

Connection of 2, 3 or 4 3A300 DC Intertrip stations onto a single pilot is possible. Where there is more than one slave station the master station should be located centrally.

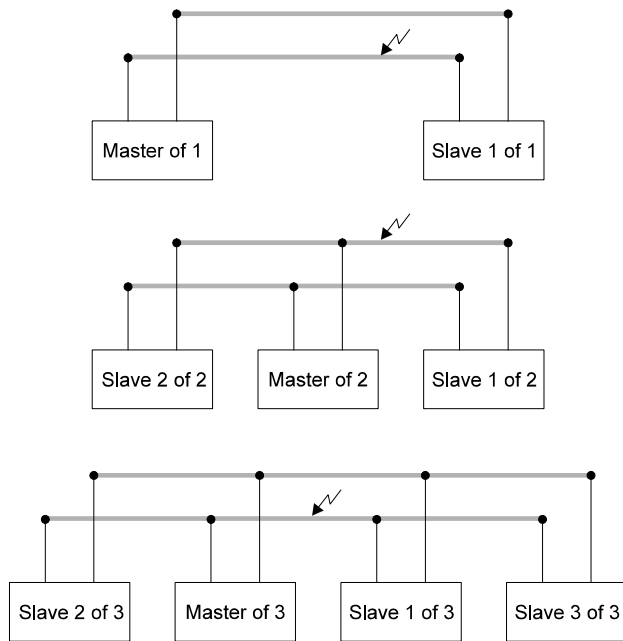

Figure 1

## COMPATIBILITY WITH OTHER DC INTERTRIP SYSTEMS

It is possible to interface a 3A300 Intertrip station with existing DC intertrip receive relays. It is not possible however to utilize the integrated supervision facilities nor can the bi-directional intertripping capabilities be exploited.

# Intertrip Applications

## TYPICAL APPLICATIONS

Typical circuit applications are shown for 2, 3 & 4 station intertripping schemes.

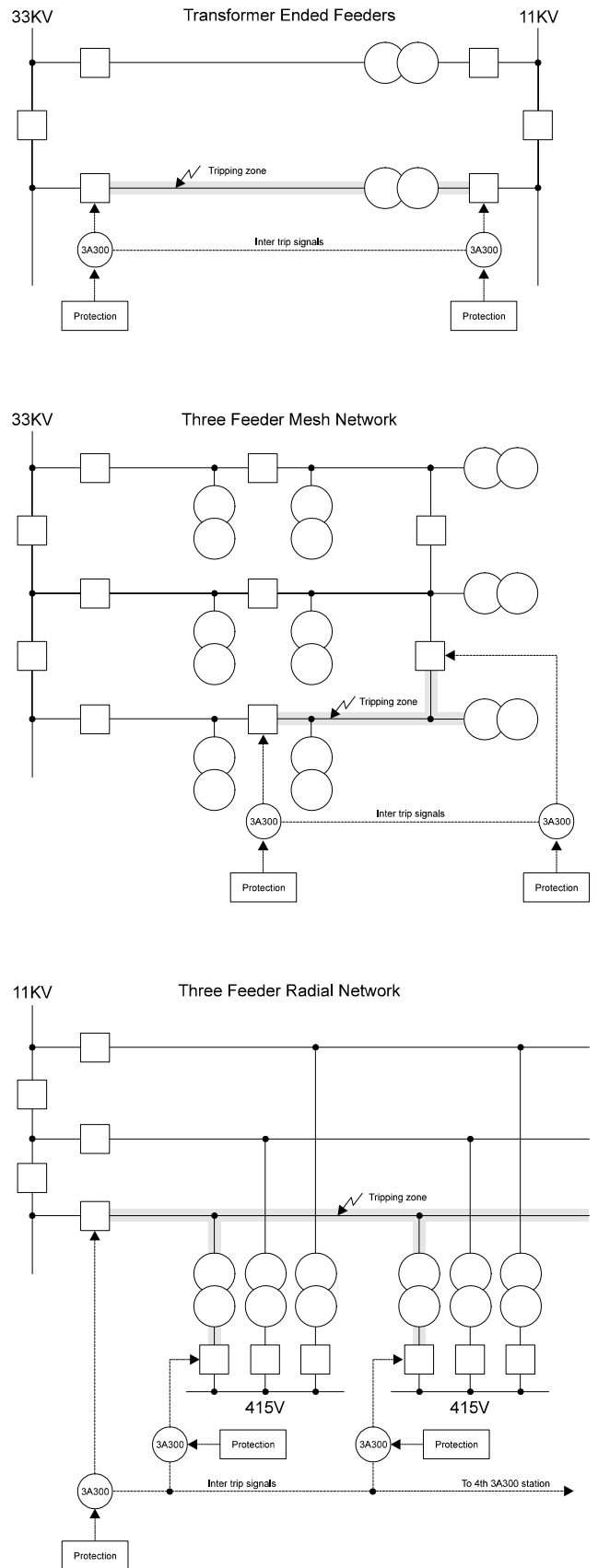

Figure 2

# REYROLLE

## INTERTRIP TIMES

System intertrip times are defined as the time from application of the intertrip send signal to closure of the intertrip receive contacts at the remote station.

Intertrip send times are a combination of the series events which take place in the system when a send command is received:

### 1. Intertrip send signal processing

Typically 10ms. This high speed input requires a minimum operate current of 50mA at 48V DC to ensure security due to induced AC noise on the control wiring.

### 2. Intertrip voltage line charging curve

When applied the 180V DC trip voltage charges the line based on an RC timing curve. The time taken to reach the trip threshold at each remote station is dependant on the pilot line impedance & the number of stations. Typically 10ms.

### 3. Intertrip Receive Element

The intertrip receive element is designed for immunity to 50Hz AC signals up to 400V for 3s. This AC rejection filter adds a typical time delay of between 11 & 22ms.

### 4. Series Intertrip Receive Relay Contacts

Four high speed series relay contacts are provided for direct tripping of local circuit breakers. This introduces a 7ms delay.

### 5. Total End To End Intertrip Times

Pilot Line		2 Stations	3 Stations	4 Stations
0Ω	0uF	38ms	42ms	46ms
2,000Ω	0uF	40ms	45ms	52ms
0Ω	2uF	43ms	47ms	51ms
1,000Ω	1uF	45ms	50ms	55ms
2,000Ω	2uF	46ms	47ms	61ms

Typical intertrip times

## INTERTRIP SEND INITIATION INPUT

Initiation from a fleeting or continuous input signal may be used as depicted in figure 3. The initiating station will not respond to its own intertrip send signal. During the 2s intertrip pulse the station sending the intertrip signal will not respond to any intertrip receipt signals. Pilot wire supervision functions are suspended during an intertrip event to avoid spurious alarms.

## SYSTEM RESET TIME

The station initiating the intertrip send signal will reset 2s after the completion of the 2s intertrip pulse & removal of the initiate signal.

The receive stations will reset 2s after the intertrip signal has concluded. Front panel indicators are hand or electrical reset.

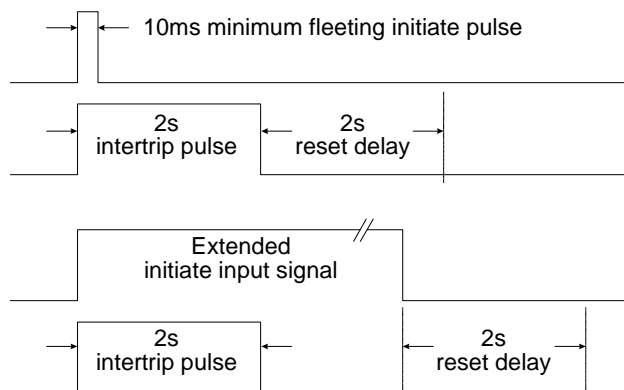

Figure 3

# Intertrip Operation

## INTERTRIP SEND CONFIGURATION

The intertrip send signal can be set to operate in two modes as shown in figure 4:

### CPU Intertrip Mode (Default)

In this mode the intertrip send command is routed through the CPU which introduces a de-bounce time (Default factory setting of ~10ms) to improve system security & is the preferred mode of operation. The default factory configuration is the CPU mode with the direct intertrip send link not fitted.

### Direct Intertrip Mode

In this mode the direct intertrip send link is fitted to allow the Intertrip send signal to be fed directly to the intertrip send circuit. This ensures that the intertrip send function will operate even in the event of CPU failure & reduces the typical intertrip times by the ~10ms de-bounce time.

If the direct intertrip mode is to be used it is recommended that the external wiring from the initiate contact to the intertrip send input be kept short & shielded cable employed to reduce the risk of induced voltage signals & possible mal operation. The relatively high operate current of this input is designed to improve security.

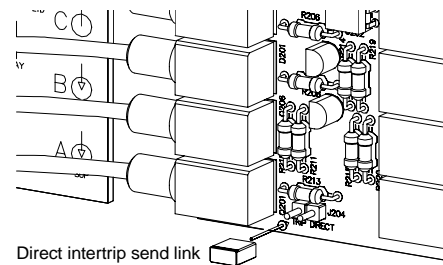

Figure 4

## PILOT WIRE ISOLATION

The 5KV & 15KV RMS isolation level is achieved using a compact encapsulated isolating transformer & fibre optic links.

### Isolating Power Supply

Isolation is provided between the pilot wires & all other case terminals. This is achieved within the device using a specially fabricated high voltage isolating transformer. *No external isolating components are required.*

### Intertrip Send & Receive

Transmission of the intertrip send & receive signals across the high voltage isolation barrier is achieved using an optical transmitter, optic fibre cable, & optical receiver.

### Supervision Signal Send & Receive

Supervision send & receive signals are transmitted across the high voltage isolation barrier using an optical transmitter, optic fibre cable & optical receiver.

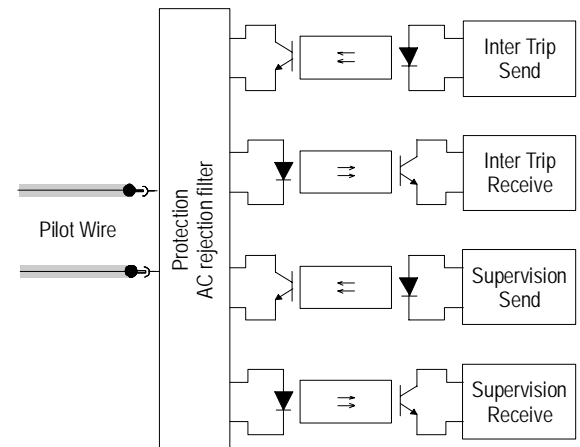
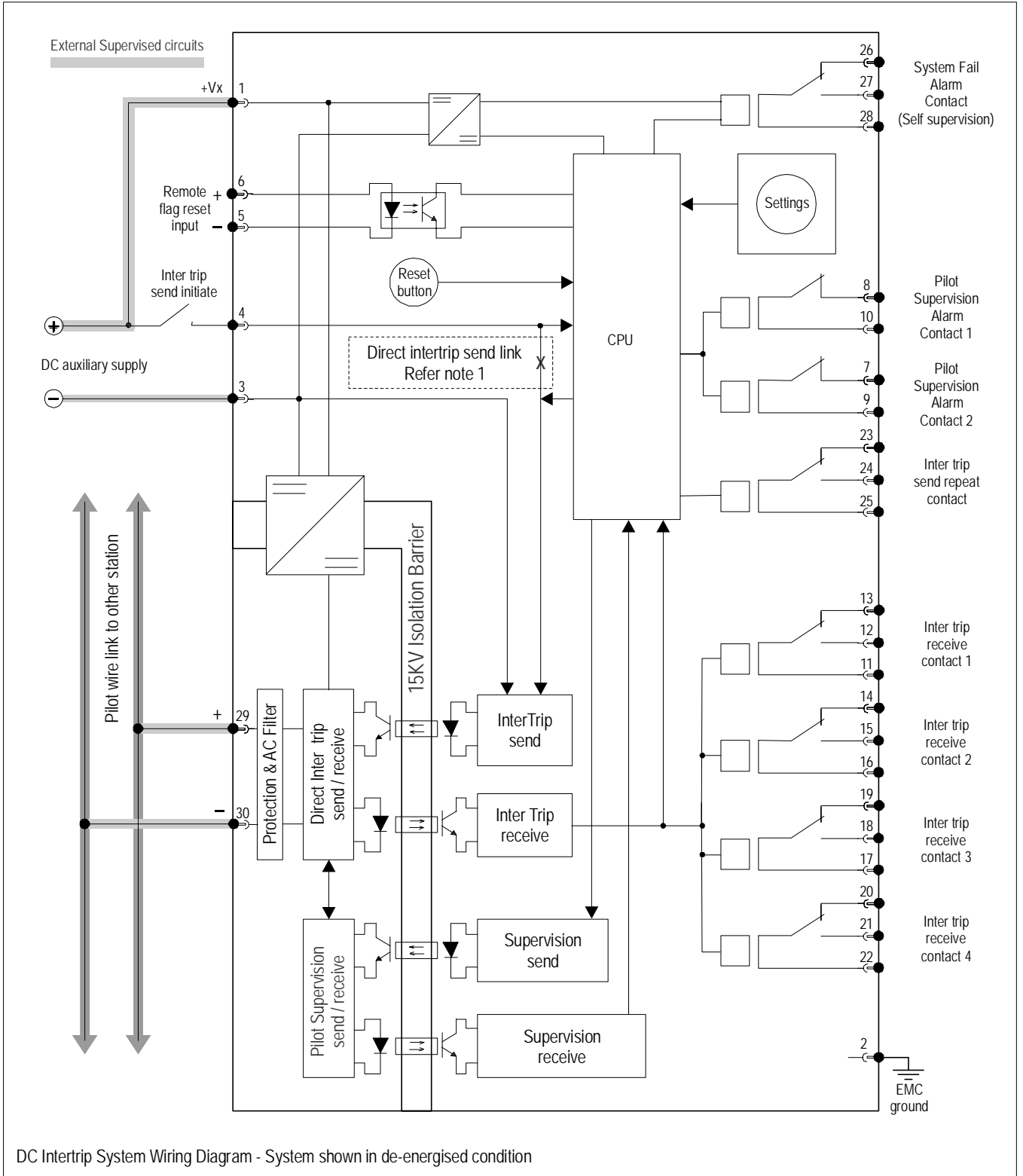

Figure 5: Fibre optic links across isolation barrier block diagram



DC Intertrip System Wiring Diagram - System shown in de-energised condition

Figure 6

- Note 1:** The factory default mode of operation is with the direct intertrip link removed. Refer to the Intertrip Send Configuration section for details. The direct intertrip send link may be fitted in the field by a qualified technician.
- Note 2:** If the 3A300 is mounted in a metal cubicle or rack the EMC ground must be connected to the chassis ground.

# REYROLLE

## SUPERVISION SETTING MODE

The intertrip supervision mode is selected using the dial selection on the front panel. OFF, Continuous & Pulse modes are available as depicted in figure 7. Unless supervision is turned OFF, one station must be set as the Master & all other stations as Slaves.

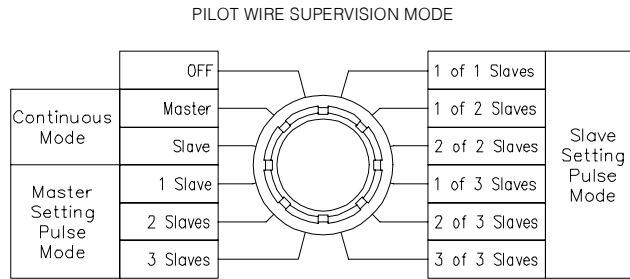

Figure 7

## PULSE MODE PILOT WIRE SUPERVISION

In this mode the Master unit outputs a DC pulse code as per figure 8. At the 750ms point the Slave units decode this signal as the Master supervisory interrogation pulse & establish synchronization for the supervision sequence. Each Slave responds in turn with a single 250ms DC pulse. The Master unit & each other Slave unit detect this return DC pulse to maintain the pilot wire supervision healthy LED's (Figure 9).

An important attribute of this mode of operation is that each station monitors all other stations for their return pulse sequence to confirm correct supervision function.

If a station fails to detect a supervision pulse an alarm timer equivalent to three supervision cycles is started. This results in a nominal supervision time delay of 4.5s for 1 slave, 6s for 2 slaves & 7.5s for 3 slaves. Recovery of the lost supervision pulse during this interval will reset the timer. Expiration of the timer will cause the supervision alarm contacts to be set.

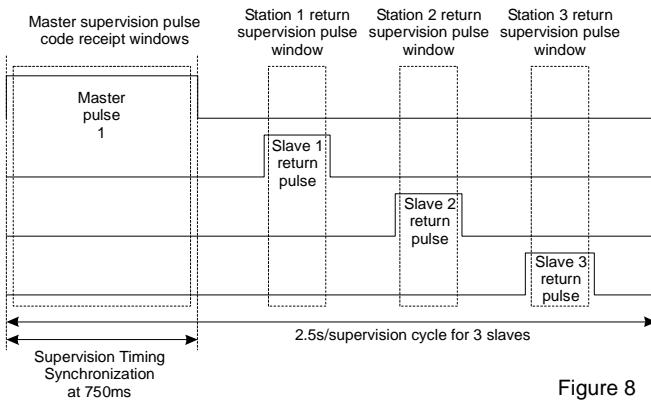

Figure 8

Timing diagram for a single supervision cycle

If the master station reset button or remote reset status input is activated for 2s a re-start will be initiated which will automatically re-synchronise the supervision system at all stations.



Figure 9

Flashing red alarm LED's indicate an ongoing pilot supervision failure condition. Solid red LED's indicate a pilot supervision alarm has occurred but has been corrected. Press the reset button to clear.

Only the green Healthy & red alarm LED's for connected slave stations are active.

# Pilot Wire Supervision

## PILOT OPEN CIRCUIT FAULT LOCATION (Pulse mode)

Both the master & slave stations are able to detect pilot open circuit faults. In the simple two station configuration (Figure 1) an open circuit fault will cause the slave to display a Master Signal alarm. The Master will display a Slave 1 alarm.

Where additional slaves are installed the alarm displayed will depend on their position on the pilot relative to the master station and the pilot open circuit. If they are on the other side of the master away from the fault they will display a Slave 1 alarm. If they are positioned after slave 1 away from the master they will display a Master Signal alarm.

## PILOT SHORT CIRCUIT FAULT LOCATION (Pulse mode)

A loss of insulation resistance across the pilot cores will lead to a reduction in the supervision voltage level applied to the pilots. A low resistance or short circuit will cause the supervision signal to be eventually lost & the associated pilot fail alarms being signalled.

## CONTINUOUS MODE PILOT WIRE SUPERVISION

In this mode the Master unit outputs a continuous 30V DC unloaded supervision signal. Each Slave & the Master monitors this signal & outputs an alarm if the signal is lost for a pre set time delay.

The advantage of this mode is simplicity. The disadvantage is that the master station will not detect pilot shorts or open circuits & the system does not provide any information on the location of the pilot fault.

In continuous supervision mode only the master signal LED's are utilized as depicted in figure 10. The slave alarm & healthy LED's remain extinguished in this mode.

Under normal conditions all stations will have the green Master signal Healthy LED energised. Failure of a slave station to detect the supervision signal from the master will change state to energize the red Alarm LED after a nominal delay of 7.5s. Supervision alarms must be cleared at each station using the front panel reset button or remote reset status input.

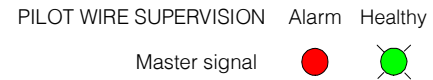

Figure 10

## PILOT WIRE SUPERVISION ALARMS

A green Healthy & a red Alarm LED is provided to report faults for each 3A300 station connected on the scheme. The function of these LED's is dependant on the supervision setting mode. Pilot wire supervision alarms are inhibited during intertrip events.

The pilot wire supervision alarm relay contacts are normally closed and are picked up only when all pilot wire supervision alarm Healthy LED's are energized. The pilot wire supervision alarm relay contacts will drop out if any of the pilot supervision red alarm LED's are flashing.

When a fault is detected the corresponding Healthy LED is extinguished, the red Alarm LED flashes & the alarm relay contacts drop out.

Flashing red alarm LED's indicate an ongoing pilot supervision failure condition. Solid red LED's indicate a pilot supervision alarm has occurred but has been corrected. In this condition the alarm contacts self reset to the picked up condition & the corresponding green Healthy LED is re-energised.

Alarm LED's can be reset by pressing the front reset button or activating the remote reset status input. If the fault is persistent the alarm condition will be re-established after the nominal 7.5s delay time.

## SUPERVISION OFF MODE

With the pilot wire supervision mode selection switch set to OFF all of the alarm & Healthy LED's remain extinguished. The alarm contact outputs remain inhibited.

This mode is useful for operating the 3A300 as an intertrip send station with existing DC intertrip relays.

# REYROLLE

## SYSTEM RELIABILITY

System reliability is primarily achieved through the application of proven technology for the critical intertrip send & receive elements. The use of high integrity optical transmitters & receivers combined with periodic supervision minimizes the potential for un-detected failure to cause a non operation at the time of an intertrip event.

The DC/DC converter power supply is of robust design & incorporates considerable protection against pilot line transients & short circuit pilots. Continuous supervision of the DC intertrip & pilot supervision voltage levels is incorporated.

## MANUAL SELF TEST SEQUENCE

When the 3A300 is first powered up a complete system self test routine is performed including a sequential LED test. The system monitoring described in this section then commences. A manual self test sequence can be initiated by pressing & holding down the reset button for 2s.

## SELF SUPERVISION ALARM CONTACT

Extensive self supervision features have been incorporated to monitor complete system integrity & output an alarm in the event of failure.

Detection of any system fault will cause the green Self Supervision "healthy" LED to flash & the normally energized Self Supervision fail alarm contact to drop out.

SELF SUPERVISION 

For diagnostic purposes three red alarm & three green healthy LED's are provided for fault identification. The function of these LED's are described in the following sections.

## POWER SUPPLY

### Auxiliary Supply Rail

Failure of the power supply will cause all LED's to be extinguished & the Self Supervision fail alarm contact to drop out.

### Intertrip Send Voltage

Availability of the DC intertrip voltage is critical to ensure reliable intertripping whenever an intertrip send initiate signal is received. A voltage monitoring circuit is provided for this purpose. Failure of this element is reported via the Self Supervision fail alarm contact & the green healthy Intertrip Send Voltage LED being extinguished.

Intertrip Send Voltage  
Supervision Send Voltage 

Availability of the DC supervision voltage is required to ensure correct operation of the pilot wire supervision system. A voltage monitoring circuit is provided for this purpose. Failure of this element is reported via the Self Supervision fail alarm contact & the green healthy Supervision Send Voltage LED being extinguished. Failure is also likely to raise pilot wire supervision alarms depending on the supervision mode selected.

Pilot Supervision Voltage 

## CPU WATCH DOG

A CPU watchdog is employed to monitor the system for correct function. The CPU performs memory & program checks & if no fault is detected a check pulse is output to reset an independent alarm timer. Failure of the CPU to provide the periodic check pulse will cause the alarm timer to expire, the Self Supervision Healthy LED to be extinguished, the CPU Alarm LED to be energised & the Self Supervision fail alarm contact to drop out. This method is employed to ensure the self supervision system is fail safe in the event of its own failure.

CPU Alarm 

# Self Supervision

## INTERTRIP SEND INPUT CIRCUIT

Provision has been made for supervision of the intertrip DC supply & the intertrip send element.

Loss of supply or failure of the intertrip send coil will result in the Intertrip Send Circuit Alarm LED to be energised & the Self Supervision fail alarm contact to drop out.

Intertrip Send Circuit Alarm 

## INTERTRIP RECEIVE OUTPUT CIRCUIT

Provision has been made for supervision of the intertrip output circuits on the non isolated side.

Failure of any of the four intertrip receive relay coils will cause the Intertrip Receive Circuit Alarm LED to be energised & the Self Supervision fail alarm contact to drop out.

Intertrip Receive Circuit Alarm 

## INTERTRIP SEND & RECEIVE OPTICAL LINK SELF TEST

The functional integrity of the optical fibre links depicted in figure 10 is monitored by the CPU. This is achieved independently at each station with a periodic 0.3ms intertrip pulse which is long enough to be captured by that stations intertrip receiver but not long enough to be detected by any other station on the pilot.

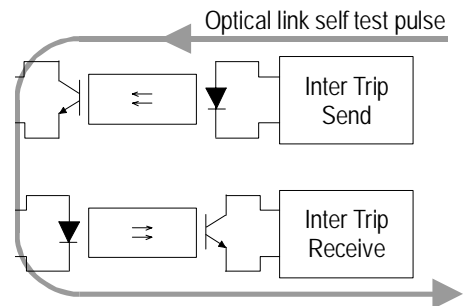

Failure of a test pulse signal being returned to the CPU will result in the Self Supervision fail alarm contact to drop out & both the Intertrip Send Circuit Alarm & Intertrip Receive Circuit Alarm LED's to be energised.

Intertrip Send Circuit Alarm 

Intertrip Receive Circuit Alarm 

The interval between the intertrip self test pulses is dependant on the pilot wire supervision mode setting. In continuous mode the test interval is 25s. In pulse mode the interval is 10 pulse cycles; ie 15s for 1 slave, 20s for 2 slaves & 25s for 3 slaves. In the event that an error is detected an additional 2.5s delay is added to re-check the optical fibre circuit before an alarm is issued.

## PILOT SUPERVISION ACTIVITY MONITOR

A Pilot Supervision Activity LED is provided for confirmation that the supervision system is functioning correctly. In continuous supervision mode this LED is continuously energised to indicate correct operation.

In pulse supervision mode the LED is flashed each time the station outputs a supervision pulse to indicate correct function.

Pilot Supervision Activity 

# REYROLLE

## AUXILIARY SUPPLY

Vx: 40-150V DC

## AUXILIARY SUPPLY BURDEN (At 110V DC)

Configured as Master: <12W in continuous supervision mode  
<10W in pulse supervision mode  
<16W in intertrip mode

Configured as Slave: <8W in continuous supervision mode  
<8W in pulse supervision mode  
<15W in intertrip mode

## PILOT WIRE OUTPUT VOLTAGE (Unloaded)

Intertrip voltage: 180V DC +/-5%  
Supervision voltage: 30V DC +/-5% - Set as Master

## INTERTRIP SEND INITIATE INPUT

Intertrip send pick up range: 25-150V DC  
Intertrip send drop off: <10V DC  
Minimum pick up current: >20mA  
Intertrip initiate signal pulse: >15ms will initiate a 2s intertrip pulse  
Intertrip initiate reset: >50ms initiate interruption

The intertrip initiate input meets the requirements of ESI48-4 EB2 at 48V DC nominal initiate voltage. Where compliance is required for 110/125V DC nominal initiate voltages, an external 1,200 ohm 10W dropping resistor must be fitted in series with terminal 4.

## PILOT INTERTRIP RECEIVE

Intertrip receive pick up: >70V DC  
Intertrip receive drop off: <50V DC

## PILOT SUPERVISION RECEIVE

Pilot supervision pick up: >9.1V DC  
Pilot supervision drop off: <9.0V DC

## REMOTE FLAG RESET INPUT

Operate voltage range: Refer ordering codes for ranges

## PILOT WIRE SUPERVISION ALARM DELAY

Continuous mode: 7.5s fixed time delay  
Pulse mode: 4.5s for 1 slave system  
6.0s for 2 slave system  
7.5s for 3 slave system

## PILOT WIRE RESISTANCE & CAPACITANCE

The 3A300 system will operate with a maximum 'balanced' pilot line load of 2K ohm resistance & 2uF capacitance. As a guide a pilot wire pair will typically present a 60 ohm resistance & 60nF capacitance per kilometer. This load is depicted in the following figure:

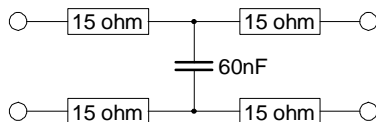

Using this pilot wire characteristic a maximum end to end pilot wire length of 30km is possible.

## FRONT PANEL INDICATORS

Healthy LED colour: Green energized solid  
Alarm LED colour: Red (Flashing & solid) energized

Self Supervision Green

CPU Alarm Red  
Intertrip Send Circuit Alarm Red  
Intertrip Receive Circuit Alarm Red  
Intertrip Send Voltage Green  
Pilot Supervision Voltage Green  
Pilot Supervision Activity Green flashing

## Intertripping

Intertrip Send in Progress Latching - hand or electrical reset  
Intertrip Receive in Progress Latching - hand or electrical reset

## Pilot Wire Supervision

Master Signal Alarm red & Healthy green  
Slave 1 Alarm red & Healthy green  
Slave 2 Alarm red & Healthy green  
Slave 3 Alarm red & Healthy green

# Technical Data

## AC IMMUNITY OF INTERTRIP RECEIVE ELEMENT

50Hz version: Up to 400V RMS at 50Hz for 3s  
60Hz version: Up to 400V RMS at 60Hz for 3s

## IMPEDANCE PRESENTED TO PILOTS

22.5K ohm & 10nF

## OUTPUT CONTACTS

Intertrip receive: 4 C/O contacts  
Intertrip send repeat: 1 C/O contact  
Pilot wire supervision alarm: 2 N/C contacts  
System fail alarm: 1 C/O contact

## OUTPUT CONTACT RATINGS

Carry continuously 5A AC or DC  
Make & carry 0.5s 20A AC or DC  
L/R ≤ 40ms & V ≤ 300V 0.2s 30A AC or DC

Break capacity AC resistive 1,250VA  
I ≤ 5A & V ≤ 300V AC inductive 250VA @ PF ≤ 0.4  
DC resistive 75W

DC inductive 30W @ L/R ≤ 40ms  
50W @ L/R ≤ 10ms  
Minimum number of operations 10<sup>6</sup> at maximum load  
Minimum recommended load 0.5W limit 10mA / 5V

## TRANSIENT OVERVOLTAGE

Between all terminals & earth 5kV 1.2/50us 0.5J  
Between independent circuits without damage or flashover 5kV 1.2/50us 0.5J

## INSULATION COORDINATION

Between all terminals & earth 2.0kV RMS for 1 minute  
Between independent circuits 2.0kV RMS for 1 minute  
Across normally open contacts 1.0kV RMS for 1 minute  
Between all input terminals & pilot wire terminals 5KV RMS or 15KV RMS for 1 minute  
Between all output terminals & pilot wire terminals 5KV RMS or 15KV RMS for 1 minute

## AUXILIARY SUPPLY

Allowable breaks / dips in supply ≤ 20ms  
Collapse to zero from nominal voltage

## HIGH FREQUENCY DISTURBANCE

2.5kV 1MHz common mode No mal operation  
1.0kV 1MHz differential mode

## ELECTROSTATIC DISCHARGE

6kV contact discharge No mal operation

## RADIO FREQUENCY INTERFERENCE

10V/m, 80 TO 1,000MHz No mal operation

## FAST TRANSIENT

4kV, 5/50ns, 2.5KHz repetitive No mal operation

## CONDUCTED RFI

10V, 0.15 to 80MHz No mal operation

## TEMPERATURE RANGE

Operating: -5 to +55°C  
Storage: -25 to +75°C

## HUMIDITY

40 °C & 95% RH non condensing

## CASE

19" rack or flush mounting: 4U high rear connection  
5KV isolation size 6 case  
15KV isolation size 8 case

Front connection surface mounting version also available.

IP rating: IP5x  
Construction: Acetal & fiberglass.  
Separate pilot wire termination cover provided for the 15KV isolation version.

## REAR TERMINALS

Pilot cables: M5 studs.  
Secondary wiring: 28 M4 screw terminal s suitable for ring lugs.

# REYROLLE

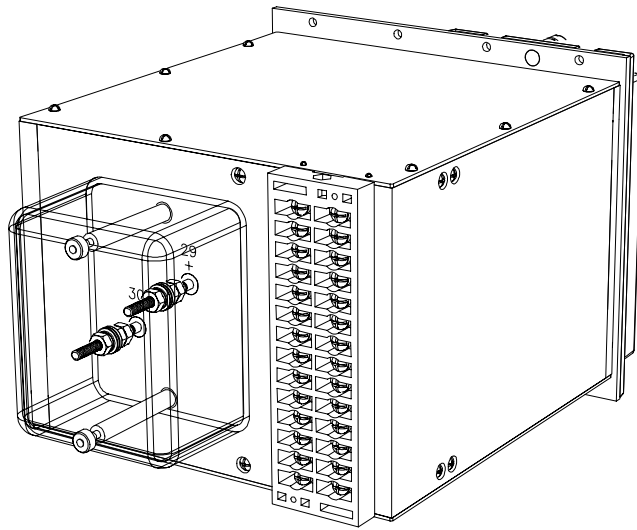

Rear view showing pilot wire & secondary terminations

## Ordering Information

Generate the required ordering code as follows: e.g. 3A300 BBBA

3A300 1 2 3 4

### 1 AUXILIARY SUPPLY RANGE

- B 40-150V DC with 50Hz AC rejection filter
- D 40-150V DC with 60Hz AC rejection filter

### 2 PILOT WIRE ISOLATION LEVEL

- A 5KV RMS
- B 15KV RMS

### 3 INTERTRIP & REMOTE RESET STATUS INPUTS

- A 24-80V DC
- B 75-150V DC

### 4 CASE MOUNTING

- A 4U high rack or flush mounting

## FRONT PANEL DETAILS & DIMENSIONS

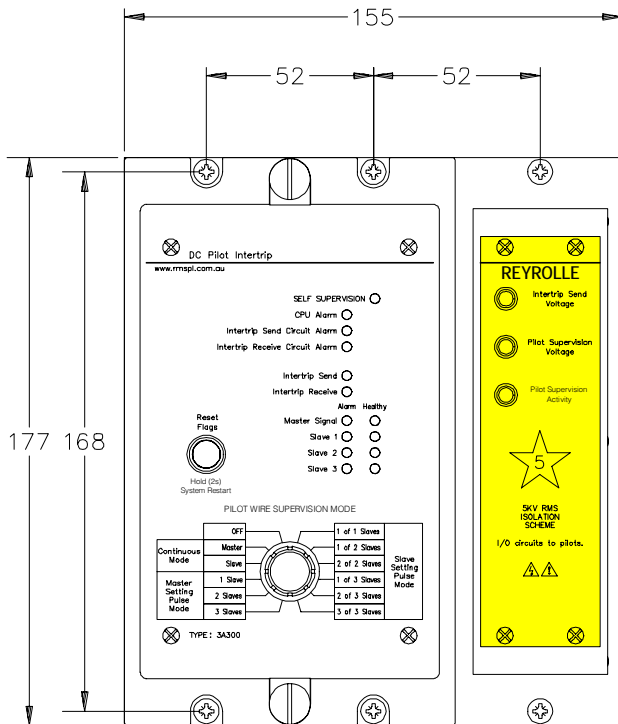

Size 6  
5KV Isolation Version

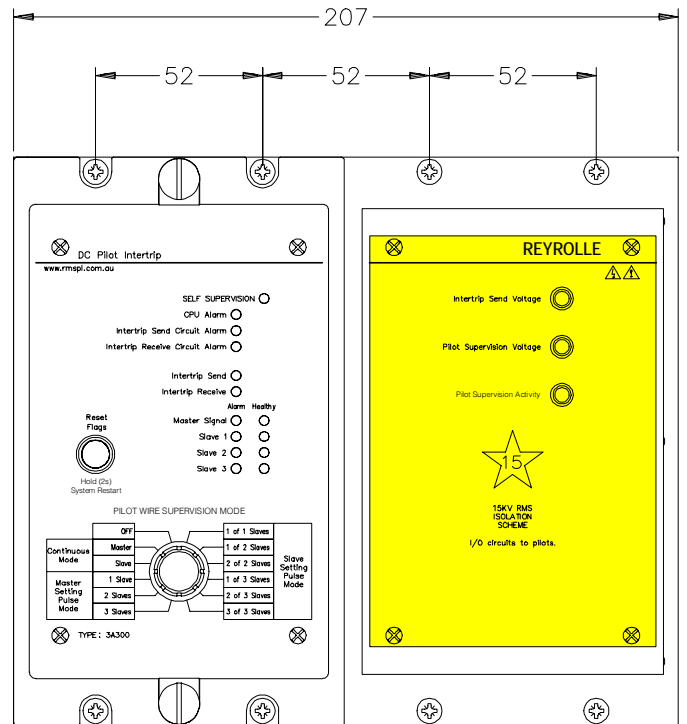

Size 8  
15KV Isolation Version

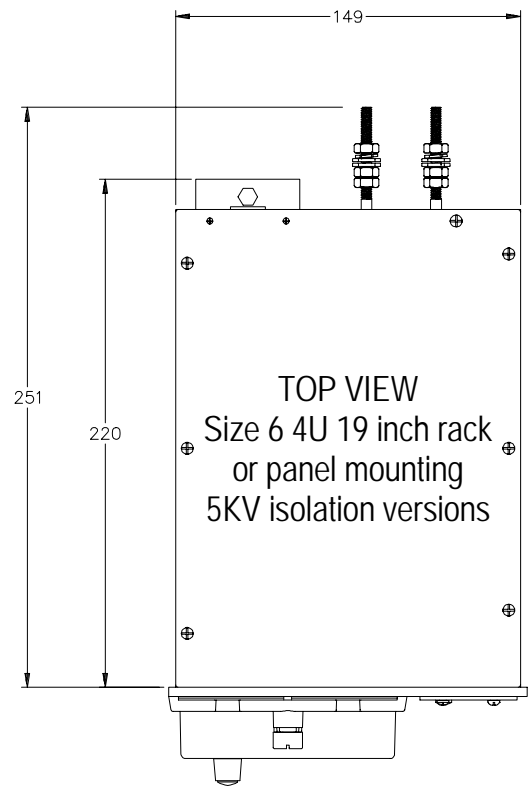
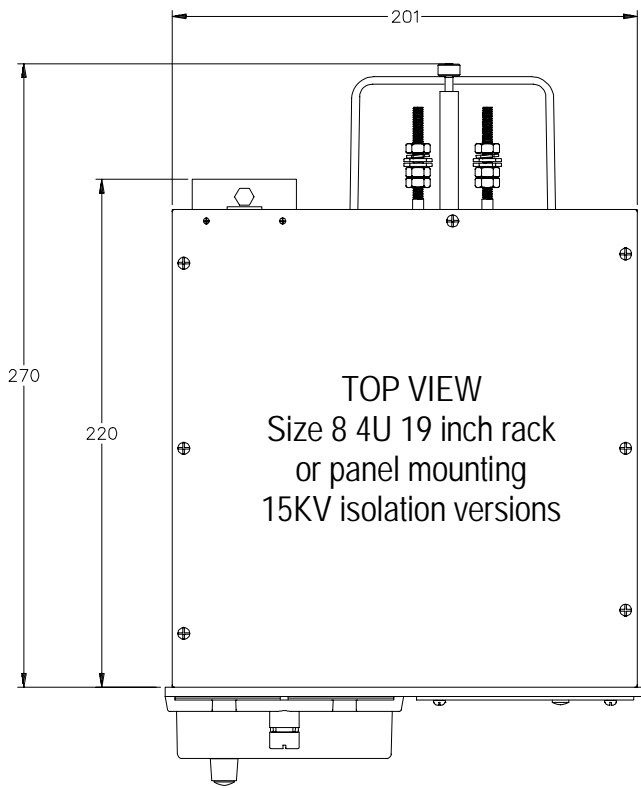
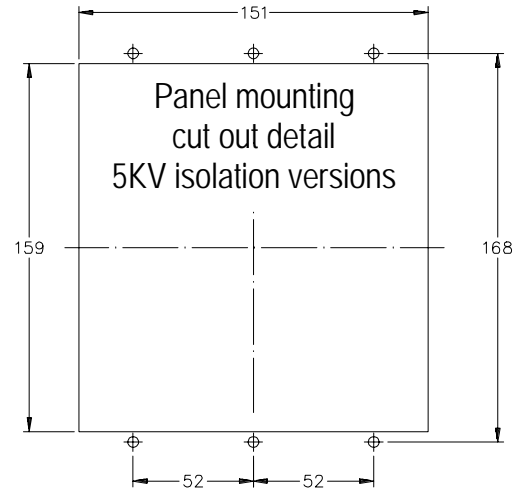
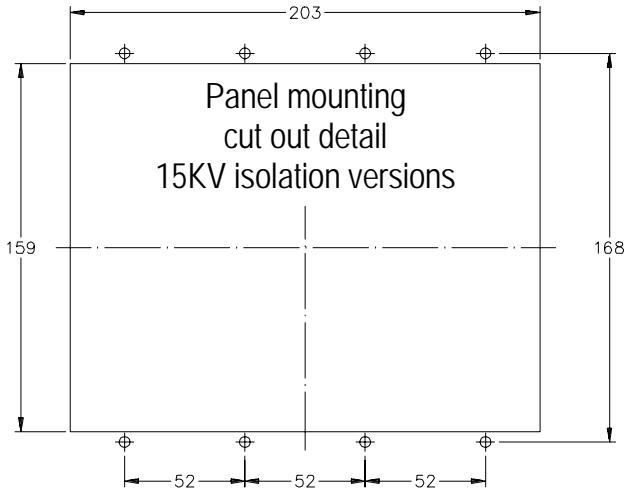

Pilot wire terminal cover  
provided with 15KV  
isolation versions only

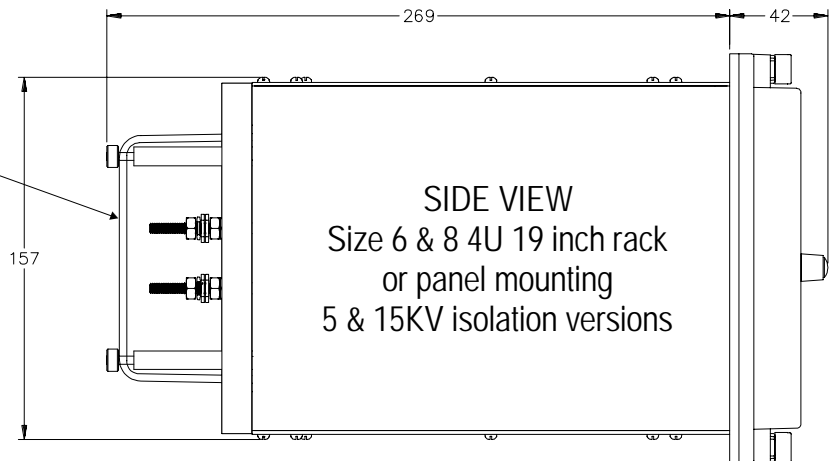

## Description of Operation

The 3A300 has only one setting control on the front panel for selection of the Pilot Wire Supervision Mode. Once this selection is made & the front cover replaced no further setting should be required.

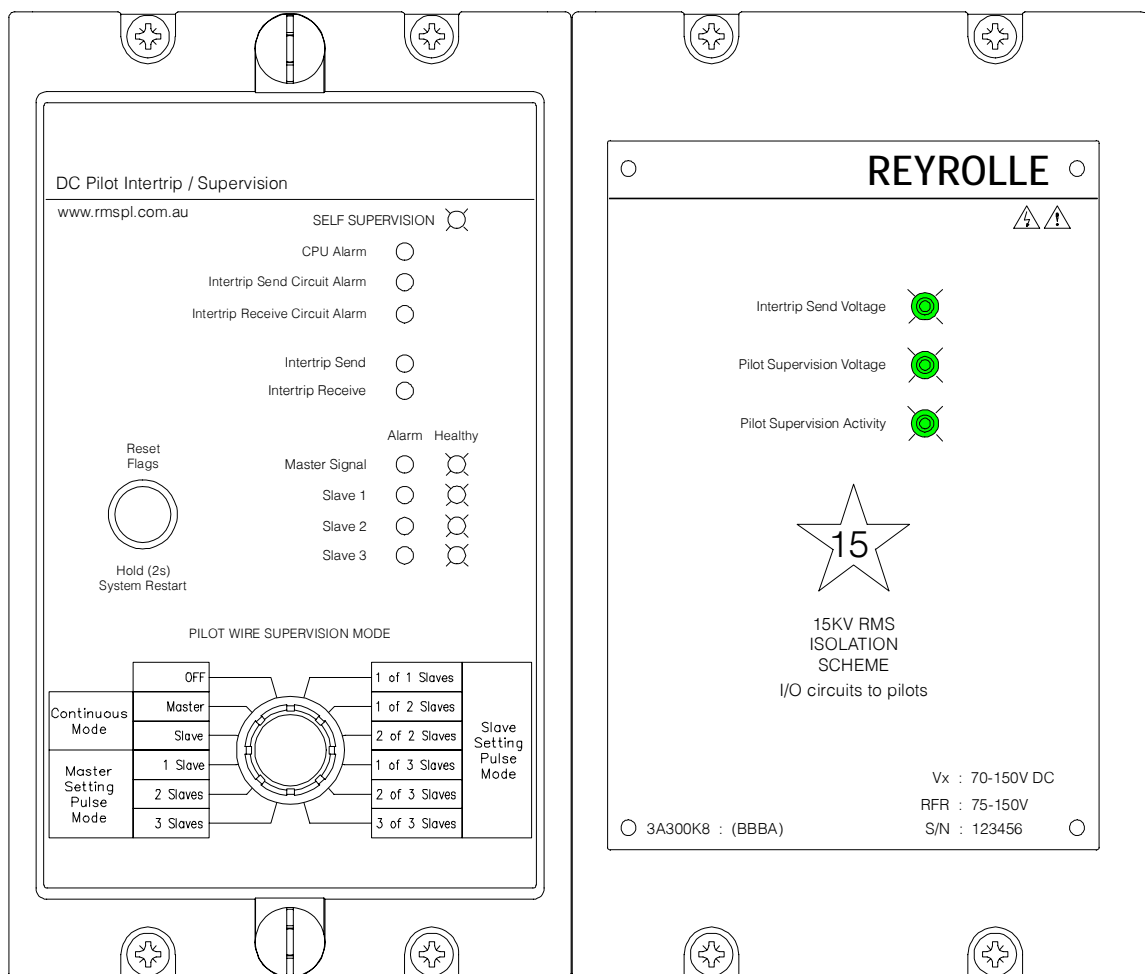

The front panel supervision mode selection & LED's are the same irrespective of the isolation model; 5KV or 15KV RMS.

For pilot wire supervision only versions the LED's relating to the DC intertrip function are not fitted.



CERTIFIED QUALITY  
MANAGEMENT SYSTEM  
ISO 9001

# REYROLLE

## Supervision Modes

Two modes of pilot wire supervision are available:

### **1. Pulse Mode Supervision**

In this mode a 30V DC nominal voltage is periodically applied to the pilots by a 3A300 station set as the Master. It is important that the total of number stations on the pilot is known when setting each station. For example if there are 4 stations on the pilot then:

One station must be set as Master – 3 Slaves

One station must be set as 1 of 3 Slaves

One station must be set as 2 of 3 Slaves

One station must be set as 3 of 3 Slaves

PILOT WIRE SUPERVISION MODE

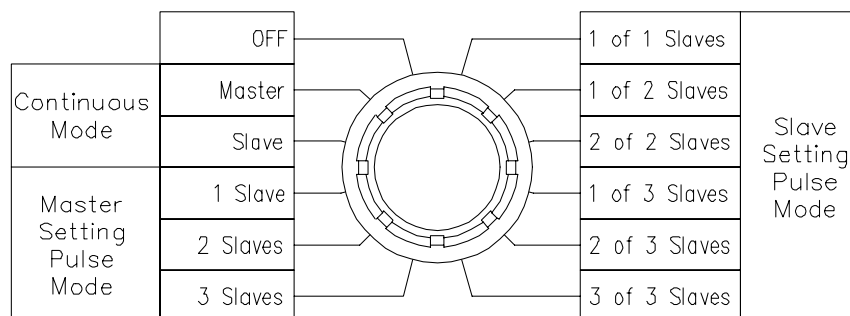

If one station is taken out of service or the supervision mode set to OFF then the setting on each of the other stations must be changed to reflect the new circumstance. For example:

One station taken out of service or set to OFF

One station must be set as Master – 2 Slaves

One station must be set as 1 of 2 Slaves

One station must be set as 2 of 2 Slaves

The advantage of this supervision mode is that each slave station responds in turn to the master supervision pulse to confirm correct functionality. When correctly configured each station on the pilot is programmed to detect the DC pulses from every other station such that the supervision system is more rigorous than the continuous supervision mode. In the event of a failure the alarm indication is more informative as to the location of the fault. Both open & short circuit pilot faults are effectively reported by the master station.



# REYROLLE

## Pilot Wire Intertrip Scheme Configurations

Two stations:

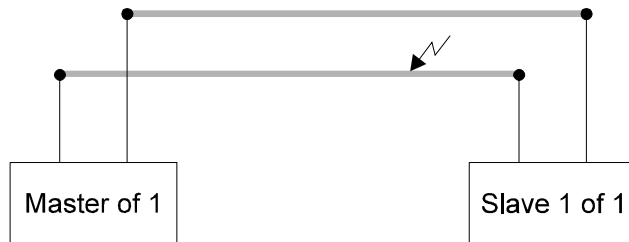

Where more than two stations are to be used on the one pilot scheme, one of the inner stations should be selected as the master. This configurations improves the diagnostic capabilities of the system in the event of a pilot failure.

Three stations:

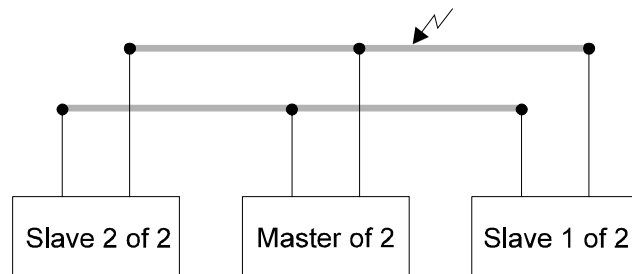

Four stations:

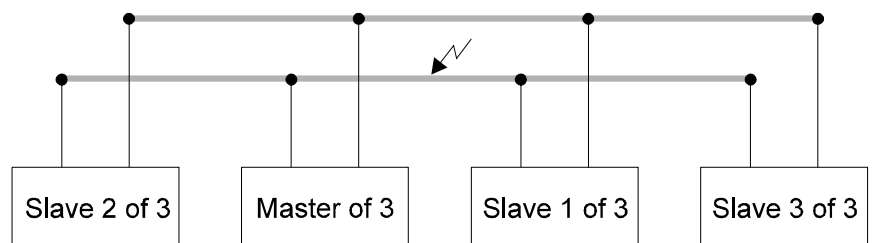

CERTIFIED QUALITY  
MANAGEMENT SYSTEM  
ISO 9001

# REYROLLE

## Pilot Wire Supervision Alarms

A green Healthy and red Alarm LED is provided to report faults for each of the pilot stations.

Note that the Pilot Wire Supervision LED's will only operate based on the Pilot Wire Supervision Settings. i.e

- If the supervision system is set to MASTER of 1 or SLAVE 1 of 1 then only the MASTER and SLAVE 1 LED's will function;
- If the supervision system is set to MASTER of 2 or SLAVE a of 2 then only the MASTER and SLAVE 1 and 2 LED's will function;
- If the supervision system is set to MASTER of 3 or SLAVE a of 3 then all the MASTER and SLAVE LED's will function;
- If Supervision is set to OFF then none of the LED's will function;
- If Supervision is set to CONTINUOUS MASTER then only the MASTER LED's will function;
- If Supervision is set to CONTINUOUS SLAVE then only the MASTER LED's will function.

A supervision alarm caused by a failure to receive a supervision pulse from another station will take precedence over the Inter trip receive circuit alarm described in section 5.5.3. This will be achieved using a delay timer on the internal Inter trip receive circuit alarm so that the fault must be continuously detected for the duration of several supervision code "receipt" pulses.

This will allow discrimination between a genuine internal system fault which will be continuous and a pilot fault which will be detected only for the duration of each supervision pulse.

This is particularly useful for detecting short circuit pilot faults occurring very close to the station which will make the outgoing pulse level to low for it's reed relay to detect.

## Pulse Mode Supervision Synchronization

When setting changes are made or 3A300 stations are powered up they self synchronize to the other stations already on the line. It is inevitable however that pilot wire supervision alarms will occur due to timing differences between stations. These alarms may be cleared in two ways:

The reset button at each 3A300 station should be pressed to clear the alarm at that station. Provided the alarm is not re-initiated this confirms the correct relative setting of all stations & supervision functionality. This reset function can also be activated using the remote reset status input on each 3A300.

The second way is to press & hold the reset button on the designated master station for 2s. This will cause a restart of this station & automatic synchronization to the other stations which will clear the alarms at all station. Provided the alarms are not re-initiated this confirms the correct relative setting of all stations & supervision functionality. This restart function can also be activated using the remote reset status input for 2s.

## Pilot Supervision Alarm Output Contacts

The pilot wire supervision alarm relay contacts are normally closed and are picked up only when all of the pilot wire supervision alarm Healthy LED's are energised. The pilot wire supervision alarm relay contacts will drop out if any of the pilot supervision alarm LED's are energised.



# REYROLLE

## 2. Continuous Mode Supervision

In this mode a 30V DC nominal voltage is continuously applied to the pilots by a 3A300 station set as the Master. Up to three additional 3A300 stations may be connected across the pilot wire & set as Slave stations. These stations monitor the 30V DC supervision voltage level & will output an alarm in the event that this signal is lost.

The advantage of this mode is the simplicity & compatibility with other systems that operate using a continuous DC supervision voltage.

The draw back is the limited information provided in the event of loss of the DC supervision signal. A failure is reported at each station but no information on the location of the fault. A pilot open circuit fault will not be reported by the master station. It is also possible that a pilot short circuit will not be detected or reported by the master station. It is also not possible to clear supervision alarms by resetting the master 3A300 station. These short comings are addressed by the pulse mode supervision scheme.

### Pilot Wire Intertrip Scheme Configurations



### Continuous Mode Supervision Synchronization

When setting changes are made or 3A300 stations are powered up they self synchronize to the other stations already on the line. It is inevitable however that pilot wire supervision alarms will occur due to timing differences between stations.

These alarms can only be cleared in the continuous supervision mode by pressing the reset button at each 3A300 station. Provided the alarm is not re-initiated this confirms the correct relative setting of all stations & supervision functionality. This reset function can also be activated using the remote reset status input on each 3A300.

### Pilot Supervision Alarm Output Contacts

The pilot wire supervision alarm relay contacts are normally closed and are picked up only when all of the pilot wire supervision alarm Healthy LED's are energised. The pilot wire supervision alarm relay contacts will drop out if any of the pilot supervision alarm LED's are energised.





CERTIFIED QUALITY  
MANAGEMENT SYSTEM  
1503001

# REYROLLE

## Intertrip Function

The DC intertrip signal can be initiated from any station on the pilot wire irrespective of the supervision mode setting. An intertrip is initiated by the application of the auxiliary voltage to the intertrip initiate input at one of the stations.

Intertrip send in progress 

Intertrip receive in progress 

The intertrip send LED is self reset. The intertrip receive LED will latch upon receipt of an intertrip & may be reset by pressing the front panel reset button or by application of a voltage to the remote reset status input.

The intertrip receive output contacts are self reset.

The intertrip send command signal may be fleeting (10ms minimum) & results in a 2s intertrip pulse output. The signal may also be continuous in which case the intertrip pulse output will be truncated to 2s. Reset is effected by removal of the initiate signal for >50ms after expiry of the 2s intertrip pulse.

The intertrip send repeat contact is self reset.

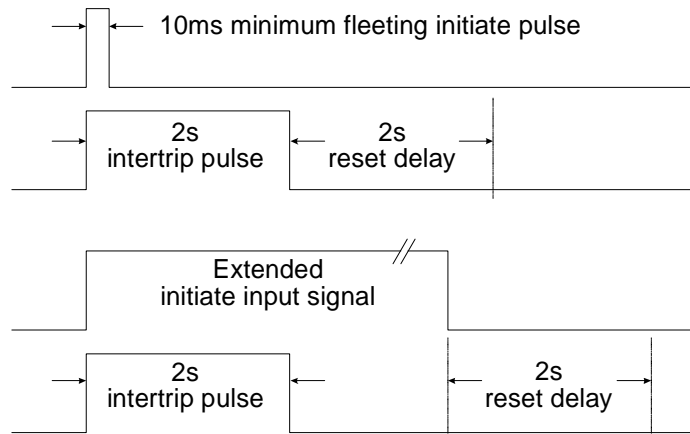

To increase system reliability the 3A300 is designed such that the intertrip send command will function irrespective of the CPU state. For example if the CPU is locked up & the resulting system fail alarm not attended to, an intertrip signal will still be generated on command. In this instance the intertrip pulse length will follow the initiate input signal.

An alternative mode is available by changing a link on the CPU PCB to only allow intertrip events to occur provided the CPU is functional.



CERTIFIED QUALITY  
MANAGEMENT SYSTEM  
ISO 9001

# REYROLLE

## Intertrip Event Operate Times

3A300 SEND & RECEIVE TIME DELAY DEFINITIONS									
SEND STATION				PILOT WIRE		RECEIVE STATION(S)			
Intertrip send status input	CPU processing	IR Link to hazardous side & photomos	Transmit filter	Transmission delays dependant on number of stations and pilot wire characteristics		50Hz rejection receive filter	IR link to safe side	Output de-bounce (PU & DO delay)	Output relay
<b>A</b>	<b>B</b>	<b>C</b>	<b>D</b>	<b>E</b>		<b>F</b>	<b>G</b>	<b>H</b>	<b>I</b>

Pilot R K ohms	Pilot C uF	No. 3A300 Stations	DELAY (msec)									Total
			A	B	C	D	E	F	G	H	I	
0	0	2	9.0	6.3	0.5	1.0	0.0	11.8	0.0	0.0	9.5	38.0
2	0	2	9.0	6.3	0.5	1.0	0.0	13.1	0.0	0.0	9.5	39.3
0	2	2	9.0	6.3	0.5	1.0	4.6	11.8	0.0	0.0	9.5	42.6
2	2	2	9.0	6.3	0.5	1.0	6.7	13.1	0.0	0.0	9.5	46.0
0	0	3	9.0	6.3	0.5	1.0	0.0	15.1	0.0	0.0	9.5	41.3
2	0	3	9.0	6.3	0.5	1.0	0.0	18.2	0.0	0.0	9.5	44.5
0	2	3	9.0	6.3	0.5	1.0	5.0	15.1	0.0	0.0	9.5	46.3
2	2	3	9.0	6.3	0.5	1.0	7.5	18.2	0.0	0.0	9.5	52.0
0	0	4	9.0	6.3	0.5	1.0	0.0	19.0	0.0	0.0	9.5	45.2
2	0	4	9.0	6.3	0.5	1.0	0.0	25.2	0.0	0.0	9.5	51.5
0	2	4	9.0	6.3	0.5	1.0	5.4	19.0	0.0	0.0	9.5	50.6
2	2	4	9.0	6.3	0.5	1.0	8.7	25.2	0.0	0.0	9.5	60.2



CERTIFIED QUALITY  
MANAGEMENT SYSTEM  
ISO 9001

Due to RMS continuous product improvement policy this information is subject to change without notice. 3A300\_Guide\_Reyrolle Iss/E/31/05/06

## Installation

### Handling of Electronic Equipment

A person's normal movements can easily generate electrostatic potentials of several thousand volts. Discharge of these voltages into semiconductor devices when handling electronic circuits can cause serious damage, which often may not be immediately apparent but the reliability of the circuit will have been reduced.

The electronic circuits of Relay Monitoring Systems Pty Ltd products are immune to the relevant levels of electrostatic discharge when housed in the case. Do not expose them to the risk of damage by withdrawing modules unnecessarily.

Each module incorporates the highest practicable protection for its semiconductor devices. However, if it becomes necessary to withdraw a module, the following precautions should be taken to preserve the high reliability and long life for which the equipment has been designed and manufactured.

1. Before removing a module, ensure that you are at the same electrostatic potential as the equipment by touching the case.
2. Handle the module by its front-plate, frame, or edges of the printed circuit board.
3. Avoid touching the electronic components, printed circuit track or connectors.
4. Do not pass the module to any person without first ensuring that you are both at the same electrostatic potential. Shaking hands achieves equipotential.
5. Place the module on an antistatic surface, or on a conducting surface which is at the same potential as yourself.
6. Store or transport the module in a conductive bag.

If you are making measurements on the internal electronic circuitry of an equipment in service, it is preferable that you are earthed to the case with a conductive wrist strap.

Wrist straps should have a resistance to ground between 500k – 10M ohms. If a wrist strap is not available, you should maintain regular contact with the case to prevent the build up of static.

Instrumentation which may be used for making measurements should be earthed to the case whenever possible.

# REYROLLE

## Safety Section

This Safety Section should be read before commencing any work on the equipment.

## Explanation of Symbols & Labels

The meaning of symbols and labels which may be used on the equipment or in the product documentation, is given below.

**Caution:** refer to product information



**Caution:** risk of electric shock

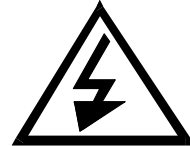

### Functional earth terminal

**Note:** this symbol may also be used for a protective/safety earth terminal if that terminal is part of a terminal block or sub-assembly eg. power supply.



CERTIFIED QUALITY  
MANAGEMENT SYSTEM  
ISO 9001

# REYROLLE

## Unpacking

Upon receipt inspect the outer shipping carton or pallet for obvious damage.

Remove the individually packaged relays and inspect the cartons for obvious damage.

To prevent the possible ingress of dirt the carton should not be opened until the relay is to be used. Refer to the following images for unpacking the relay:

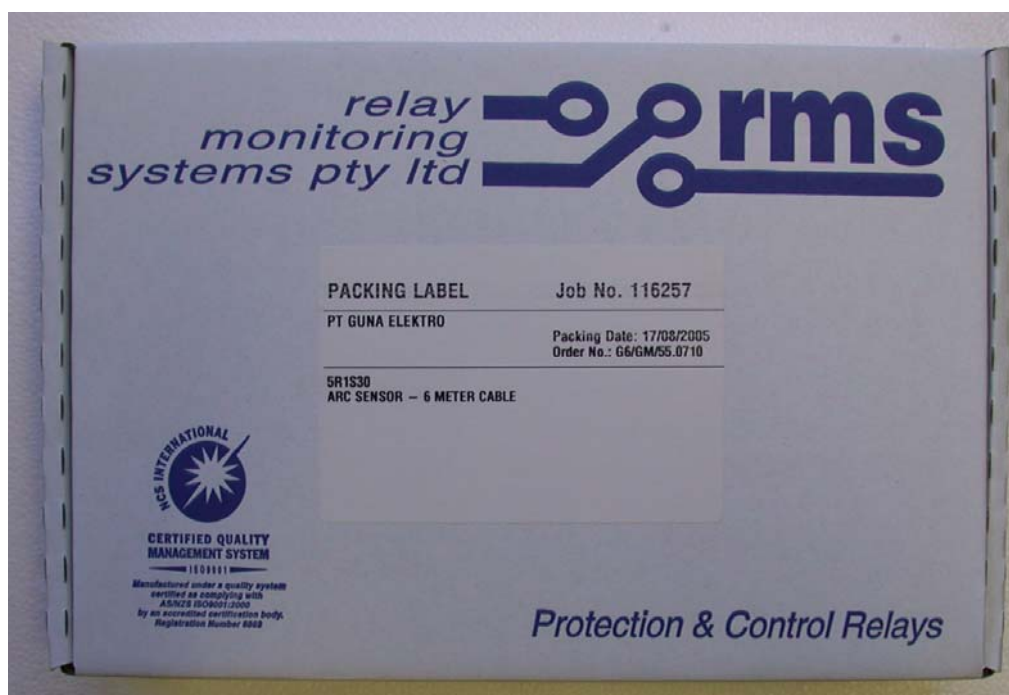

Inner packing carton showing front label detailing the customer name, order number, relay part number & description, the relay job number & packing date.

(Size 2 inner packing carton depicted)

# REYROLLE

## Accessories Supplied With Each Relay



Self threading M4 mounting screws



M4 terminal screws with captured lock washers

### Storage & Handling

If damage has been sustained a claim should immediately be made against the carrier, also inform Relay Monitoring Systems Pty Ltd and the nearest RMS agent

When not required for immediate use, the relay should be returned to its original carton and stored in a clean, dry place.

### Recommended Mounting Position

The relay should be mounted on the circuit breaker or panel to allow the operator the best access to the relay functions.

### Relay Dimensions & Other Mounting Accessories

Refer drawing in Technical Bulletin. Relevant Auto Cad files & details on other accessories such as 19 inch sub rack frames, semi projection mount kits & stud terminal kits may be down loaded from:

<http://www.rmspl.com.au/MSeries.htm>



CERTIFIED QUALITY  
MANAGEMENT SYSTEM  
ISO 9001

Due to RMS continuous product improvement policy this information is subject to change without notice. 3A300\_Guide-4\_Reyrolle/Iss D/31/03/06

# REYROLLE

## Equipment Connections – Isolated Side

Personnel undertaking installation, commissioning or servicing work on this equipment should be aware of the correct working procedures to ensure safety. The product documentation should be consulted before installing, commissioning or servicing the equipment.

Terminals exposed during installation, commissioning and maintenance may present hazardous voltage unless the equipment is electrically isolated.

If there is unlocked access to the rear of the equipment, care should be taken by all personnel to avoid electric shock or energy hazards.

Voltage and current connections should be made using insulated crimp terminations to ensure that terminal block insulation requirements are maintained for safety. To ensure that wires are correctly terminated, the correct crimp terminal and tool for the wire size should be used.

Before energising the equipment it must be earthed using the protective earth terminal, or the appropriate termination of the supply plug in the case of plug connected equipment. Omitting or disconnecting the equipment earth may cause a safety hazard.

The recommended minimum earth wire size is 2.5mm<sup>2</sup>, unless otherwise stated in the technical data section of the product documentation.

Before energising the equipment, the following should be checked:

1. Voltage rating and polarity;
2. CT circuit rating and integrity of connections;
3. Protective fuse rating;
4. Integrity of earth connection (where applicable)

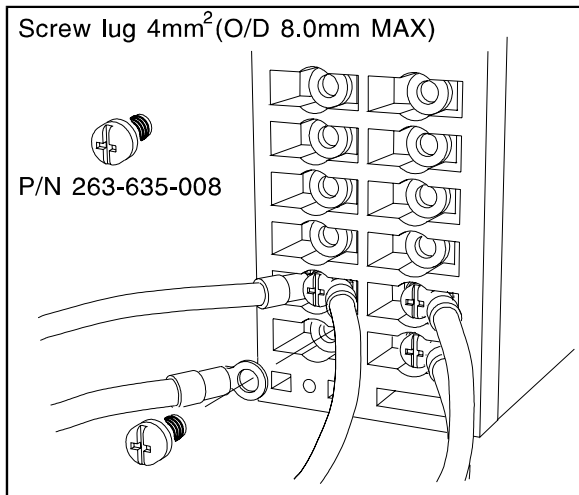

## Equipment Operating Conditions

The equipment should be operated within the specified electrical and environmental limits.



CERTIFIED QUALITY  
MANAGEMENT SYSTEM  
ISO 9001

# REYROLLE

## Pilot Wire Termination

On 15KV isolation version 3A300 units, the M5 pilot wire termination studs have a clear polycarbonate cover which are located by insulating thumb screws top & bottom. Pilot cables may be terminated from the left side (Viewed from the back), or the top or bottom. Installation of the pilot wires requires holes to be drilled in the cover of appropriate diameter to suit the termination lugs employed. The following images depict typical positions for these holes & the pilot wire arrangement. The pilot wire cover should always be replaced before the system is energised.

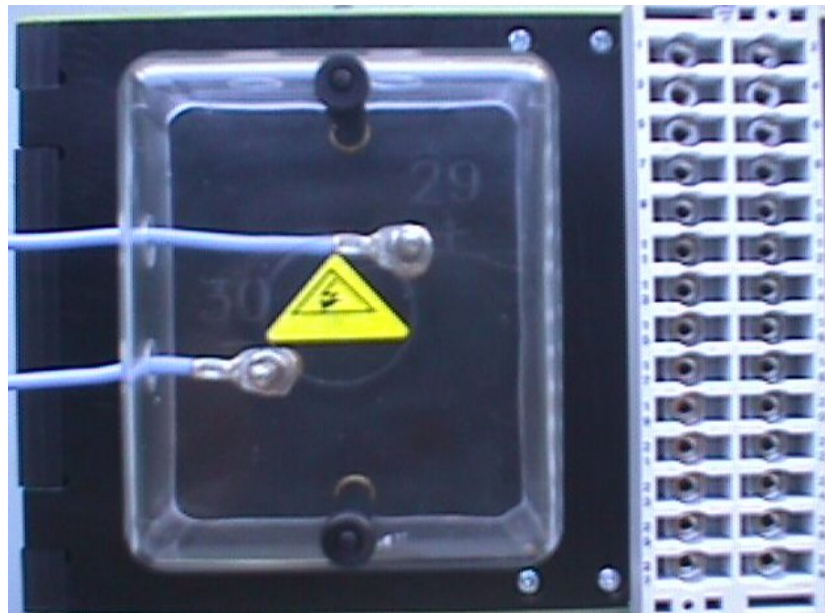

Pilot wires enter from the left side

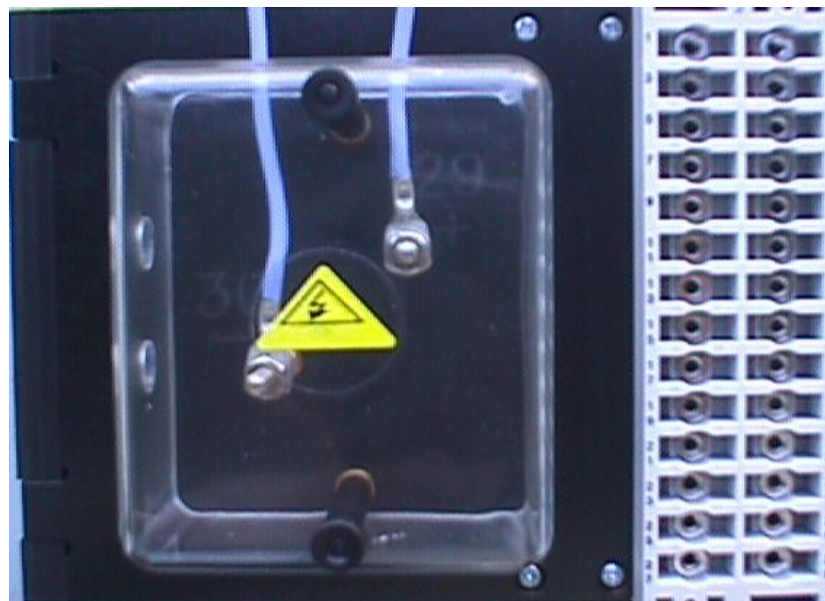

Pilot wires enter from the top (Or bottom)



CERTIFIED QUALITY  
MANAGEMENT SYSTEM  
ISO 9001

# REYROLLE

## **Commissioning – Continuous Mode Supervision**

There is only a single setting to be made at the front panel of the 3A300. Remove the front dust cover by first loosening the black top and bottom thumb screws and set aside. Take care to avoid damage to the reset button spindle or scratching the cover. Note the top and bottom yellow dust seals retained in the cover.

Rotate the Pilot Wire Supervision Mode selector switch to the required position. Unless supervision is switched OFF at all stations on the scheme there must be at least one Master and one Slave station selected.

For Continuous Mode Supervision one station should be set to the Continuous Mode Master position and all other stations to the Continuous Mode Slave position.

Once all stations on the scheme have been set and checked the front panel covers may be replaced. Each station on the scheme should now be powered up in turn and the front panel LED's under the front cover observed as they proceed through a sequential self test. Each LED should be seen to flash once to indicate correct function.

At the completion of this test all of the red LED's should at least momentarily remain extinguished and the top Self Supervision green LED remain energised.

In Continuous Supervision Mode only the Master Signal LED's will be functional and the green LED should remain energised at least momentarily.

If supervision is set to OFF then all the supervision LED's will remain extinguished.

The green LED's designated Intertrip Send Voltage, Pilot Supervision Voltage and Pilot Supervision Activity should remain continuously energised.

It is normal that supervision alarms will be activated after a 2-15s delay during the initial power up sequence due to timing differences between the stations. These alarms can be reset by pressing the reset button on each Slave station or by momentarily energising the remote reset input for each Slave station.

If the supervision alarms re-occur check that the Master station has been powered up correctly and reset all Slaves. If further alarms occur check the polarity and integrity of the pilot wire connections to all stations.

The supervision function may be checked by momentarily disconnecting one of the pilot wires at each Slave station in turn.

The intertrip function may be checked by activating the intertrip send input at each station in turn and verifying an intertrip receive contact closure at each other station.



# REYROLLE

## Commissioning – Pulse Mode Supervision

There is only a single setting to be made at the front panel of the 3A300. Remove the front dust cover by first loosening the black top and bottom thumb screws and set aside. Take care to avoid damage to the reset button spindle or scratching the cover. Note the top and bottom yellow dust seals retained in the cover.

Rotate the Pilot Wire Supervision Mode selector switch to the required position. Unless supervision is switched OFF to all stations on the scheme there must be at least one Master and one Slave station selected.

For Pulse Mode Supervision each station must have a unique setting. One station should be set to the Master Setting Pulse Mode at the position indicating the number of Slave stations connected on the scheme. Each Slave should be set to the Slave Setting Pulse Mode at the position indicating its station number of the total number of Slaves connected on the scheme.

Once all stations on the scheme have been set and checked the front panel covers may be replaced. Each station on the scheme should now be powered up in turn and the front panel LED's under the front cover observed as they proceed through a sequential self test. Each LED should be seen to flash once to indicate correct function.

At the completion of this test all of the red LED's should at least momentarily remain extinguished and the top Self Supervision green LED remain energised.

If supervision is set to OFF then all the supervision LED's will remain extinguished.

The green LED's designated Intertrip Send Voltage and Pilot Supervision Voltage should remain continuously energised. The green LED designated Pilot Supervision Activity should flash at a rate of approximately 2Hz. A long flash (Master supervision pulse), followed by a number of short flashes (Slave return pulses), equal to the number of slave stations on the system.

It is normal that supervision alarms will be activated after a 2-15s delay during the initial power up sequence due to timing differences between the stations. These alarms can be reset and the supervision system synchronised as follows:

For Pulse Mode Supervision the reset button on the Master station should be pressed and held for 3s to restart the unit. At the completion of the power up sequence a Master station synchronisation pulse is output which will automatically clear the alarms at all Slave stations. This may also be accomplished by activating the Master station remote reset input for 3s.

If the supervision alarms re-occur check that the Master station has powered up correctly and re-try. If further alarms occur check the polarity and integrity of the pilot wire connections to all stations.

The supervision function may be checked by momentarily disconnecting or shorting one of the pilot wires at each Slave station in turn.

The intertrip function may be checked by activating the intertrip send input at each station in turn and verifying an intertrip receive contact closure at each other station.



# REYROLLE

## **Commissioning – Intertrip Timing Verification**

The following instruction will work for Pulse Mode as well as DC Mode operation.

Connect the auxiliary supply to both relays.

To test the time for the Slave relay to operate when an intertrip pulse is sent from the Master relay, connect the equipment as depicted on the following page.

Initiate an Intertrip pulse by operating the “Initiate Intertrip 1” switch connected to the Intertrip Send (terminal 4 ) of the Master relay & auxiliary negative (terminal 3) and the Start Input of Timing Device 2 the closure of the “Intertrip Receive” contacts (terminals 11 & 12) on the Slave relay. The closure of these contacts will stop Timing Device 2.

The time indicated by Timing Device 2 will be the intertrip time. The indicated time will depend on the resistance and capacitance of the pilot wire, but is specified at less than 50 mS for a two station connection with 2000 ohms and 2 $\mu$ F capacitance maximum line characteristic.

To measure the operate time when the Intertrip pulse is initiated from the Slave relay, initiate the intertrip pulse by operating “Initiate Intertrip 2” switch and Timing Device 1.

To check the Supervision function of the relay open circuit or cross over the pilot connection and the MASTER relay will signal a “SLAVE 1” fault and the SLAVE will signal a “MASTER” fault. The supervision fail contacts are on terminals 8 & 10 and 7 & 9 on each of respective relays.



CERTIFIED QUALITY  
MANAGEMENT SYSTEM  
— 1 5 0 9 0 0 1 —

# REYROLLE

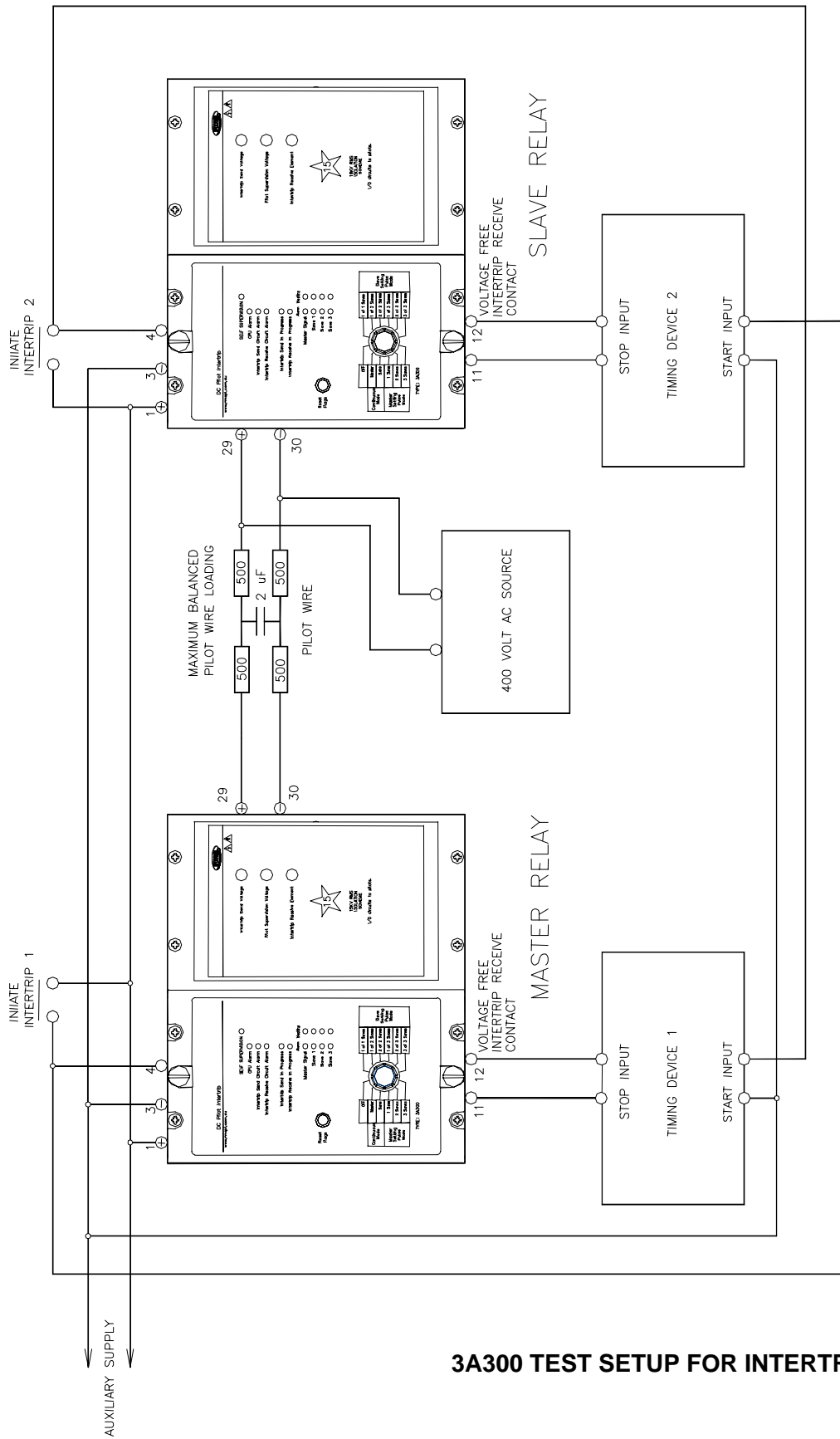

**3A300 TEST SETUP FOR INTERTRIP TIMING**



**CERTIFIED QUALITY  
MANAGEMENT SYSTEM**  
1503001

# REYROLLE

## **Insulation & Dielectric Strength Testing**

Insulation testing may leave capacitors charged up to a hazardous voltage. At the end of each part of the test, the voltage should be gradually reduced to zero, to discharge capacitors, before the test leads are disconnected.

## **Electrical Adjustments**

Pieces of equipment which require direct physical adjustments to their operating mechanism to change current or voltage settings, should have the electrical power removed before making the change, to avoid any risk of electric shock.

## **Mechanical Adjustments**

The electrical power to the relay contacts should be removed before checking any mechanical settings, to avoid any risk of electric shock.

## **Decommissioning & Disposal**

**Decommissioning:** The auxiliary supply circuit in the relay may include capacitors across the supply or to earth. To avoid electric shock or energy hazards, after completely isolating the supplies to the relay (both poles of any dc supply), the capacitors should be safely discharged via the external terminals prior to decommissioning.

**Disposal:** It is recommended that incineration and disposal to water courses is avoided. The product should be disposed of in a safe manner.



CERTIFIED QUALITY  
MANAGEMENT SYSTEM  
— 1 5 0 9 0 0 1 —

## Maintenance

### **Mechanical Inspection**

#### Relay Assembly

Inspect the relay for obvious signs of damage or ingress of moisture or other contamination.

#### Relay Case

Inspect the outer terminals checking insulation integrity & tightness.



#### Relay Module Removal if Required

Isolate the relay.

If possible remove the 2 screws top and 2 screws bottom retaining the 28 way screw terminal block. Remove the earth connection and the 28 way terminal block. Disconnect the pilot wire terminals and the relay may now be removed from the panel.

Care must be taken to avoid subjecting the relay element to static discharge which may damage or degrade sensitive electronic components.

Inspect the relay module for signs of any overheating or burn marks which may have been caused by overvoltage surge or transient conditions on the power supply or digital status inputs.

Inspect the 15KV isolating transformer for degradation of insulation on the terminal wiring & transformer windings.

# REYROLLE

## Test Intervals

The maintenance tests required will largely depend upon experience and site conditions, but as a general rule it is recommended that the following inspection and tests are performed every twelve months.

- ◆ Mechanical Inspection
- ◆ Check of Connections
- ◆ Insulation Resistance Test
- ◆ Fault Setting Tests by Secondary Injection
- ◆ Tests using Load Current
- ◆ Check the continuity of the neutral CT loop with a bell test set or an ohmmeter



# REYROLLE

## Defect Report Form

*Please copy this sheet and use it to report any defect which may occur.*

Customers Name & Address:	Contact Name:
	Telephone No:
	Fax No:
Supplied by:	Date when installed:
Site:	Circuit:

### *When Defect Found*

Date:	Commissioning?	Maintenance?	Systems Fault?	Other, Please State:
Product Part No:			Serial Number:	
Copy any message displayed by the relay:				
Describe Defect:				
Describe any other action taken:				
Signature:		Please Print Name:		Date:

### *For RMS use only*

Date Received:	Contact Name:	Reference No:	Date Acknowledged:	Date of Reply:	Date Cleared:
----------------	---------------	---------------	--------------------	----------------	---------------

