



4D200 User Guide

TPI Display Module

relay monitoring systems Pty Ltd

Advanced Protection Devices



User Guide



Test Manual



4D200 User Guide

About This Manual

This User Guide covers all 4D200 relays manufactured from May 2003. Earlier relays do not necessarily incorporate all the features described. Our policy of continuous may means that extra features & functionality may have been added.

The 4D200 User Guide is designed as a generic document to describe the common operating parameters for all relays built on this platform. Some relay applications are described but for specific model information the individual “K” number Product / Test manuals should be consulted.

The copyright and other intellectual property rights in this document, and in any model or article produced from it (and including any Registered or unregistered design rights) are the property of Relay Monitoring Systems Pty Ltd. No part of this document shall be reproduced or modified or stored in another form, in any data retrieval system, without the permission of Relay Monitoring Systems Pty Ltd, nor shall any model or article be reproduced from this document without consent from Relay Monitoring Systems Pty Ltd.

While the information and guidance given in this document is believed to be correct, no liability shall be accepted for any loss or damage caused by any error or omission, whether such error or omission is the result of negligence or any other cause. Any and all such liability is disclaimed.

Contact Us

© Relay Monitoring Systems Pty Ltd 2001-2009
6 Anzed Court • Mulgrave 3170 • AUSTRALIA
Phone 61 3 9561 0266 • Fax 61 3 9561 0277
Email rms@rmspl.com.au • Web www.rmspl.com.au

To download a PDF version of this guide:
http://www.rmspl.com.au/userguide/4d200_user_guide.pdf

To download the model specific Test Manual:
<http://www.rmspl.com.au/search.asp>

How this guide is organised

This guide is divided into five parts:

Part 1 Overview

About this Manual

Contents

Test Manual

Part 2 Mechanical Configuration

Part 3 Technical Bulletin

Part 4 Installation

Handling of Electronic Equipment

Safety

Configuration

Equipment Connections

Part 5 Maintenance

Inspection

Defect Report Form



Test Manual

This User Guide covers all 4D200 versions & describes the generic features & attributes common across all versions.

Different relay versions are required to cater for varying customer requirements such as auxiliary voltage range, I/O configuration, case style, relay functionality etc.

The product ordering code described in the Technical Bulletin is used to generate a unique version of the relay specification & is called a type number. The type number takes the form 4D200Kxx where the Kxx is the "K" or version number.

Refer to: www.rmspl.com.au/handbook/parta3.pdf
for a complete description of the RMS "K" number system.

Each 4D200 version has a specific Test Manual which provides details on the unique attributes of the relay. Each Test Manual includes the following information:

- Test Certificate
- Specific technical variations from the standard model if applicable
- Test & calibration record
- Wiring diagram

A Test Manual is provided with each relay shipped.

If you require a copy of the Test Manual for an RMS product the following options are available:

- Check the RMS web site at: www.rmspl.com.au/search.asp
- RMS CD catalogue select: [List all Product/Test Manuals](#) under [Technical Library](#)
- Contact RMS or a representative & request a hard copy or PDF by email.



Mechanical Configuration

Great care has been taken to design a rugged, cost effective & flexible mechanical solution for the 4D200 TPI Module.

The 4D200 is configured in a plastic panel mount case with plug in terminal block.

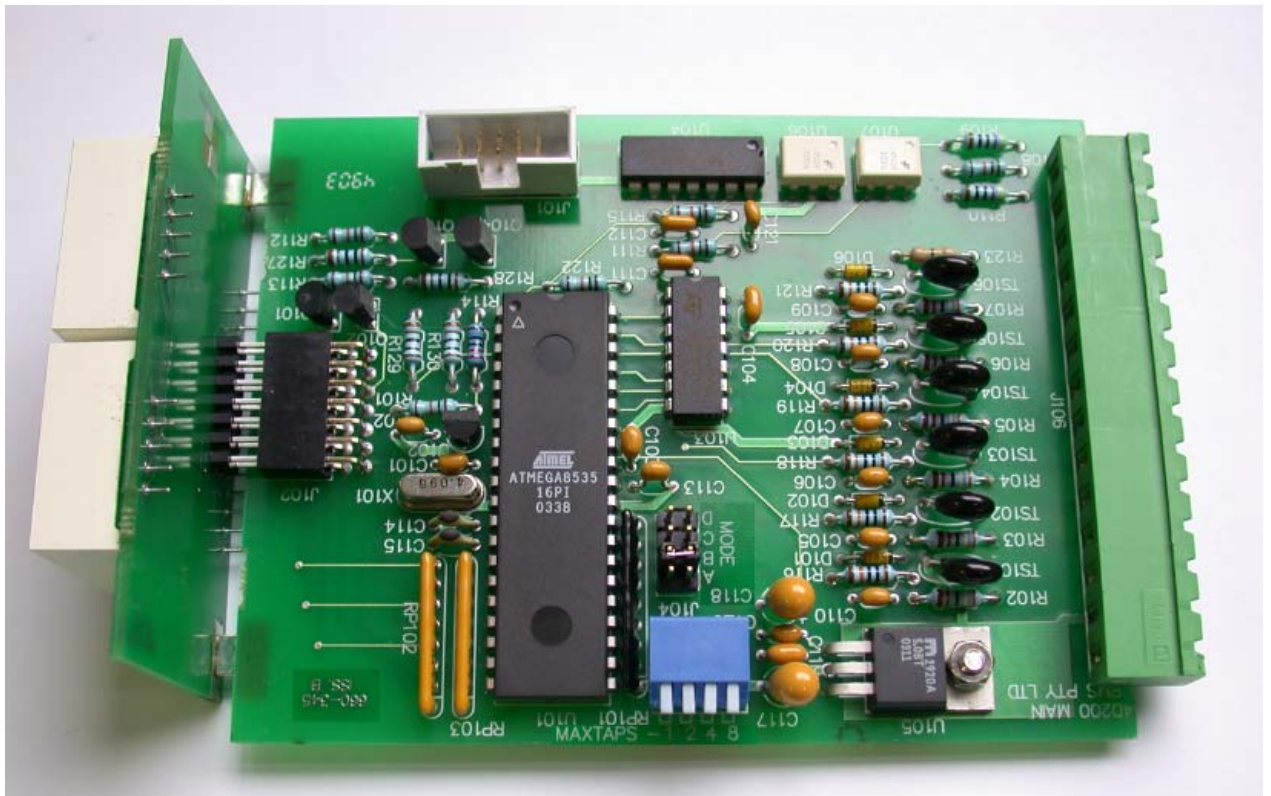



Technical Bulletin

The detailed technical attributes, functional description & performance specifications for the 4D200 are described in the attached Technical Bulletin. For the most up to date version go to:

www.rmspl.com.au/handbook/4d200.htm

For any specific attributes of a particular version refer to the Test Manual for that type (K) number.

The order of precedence for technical information is as follows:

- Test Manual
- Technical Bulletin
- User Guide

Features

- Designed to interface with the RMS 2V200 TPI transducer
- Optional BCD / BIN input interface
- Optional BCD output signaling
- Compact panel mount case
- Bright 25mm digit red LED display
- 12V DC auxiliary supply input for use with external isolating AC power adaptor
- Double insulated high impact polystyrol case
- Simple & robust construction

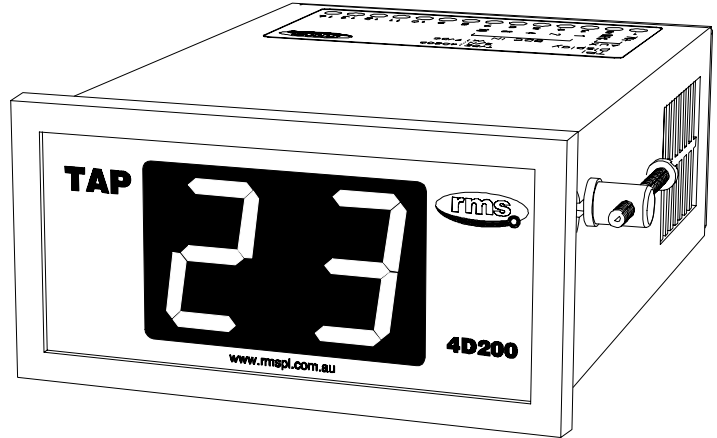

Application

The 4D200 may be applied to a number of system configurations as shown below. While the 4D200 may be specified to directly accept BCD / BIN input signals, it is more convenient to simply employ an RMS 2V200 TPI transmitter unit. Refer application block diagrams 1 & 2.

This has the advantage of only requiring a two wire connection between the 2V200 mounted at the tap changer & the 4D200 display module. Refer to the 2V200 Technical bulletin for details on the other advantages this system provides.

Description

Made in Australia

The 4D200 is a compact panel mount module incorporating 2 bright 25mm LED digits for the display of a power transformer tap position over the range TAP 1 to TAP 30.

The 4D200 is specifically designed for operation with the RMS type 2V200 TPI to frequency transducer. The 2V200 provides a noise immune interface between the tap changer & the 4D200 via a 0 to 5KHZ frequency signal.

Alternatively the 4D200 may be configured to accept a BCD / BIN coded input direct from the tap changer or via a voltage to BCD / BIN transducer.

Where an RMS 2V164 Voltage Regulating Relay is being used with a 2V200 TPI Transducer, a 4D200 may be connected in parallel to provide a local easy to read tap position indication.

The 4D200 may also be optionally specified to provide a BCD output of the tap position for interface to a SCADA system.

Application Examples

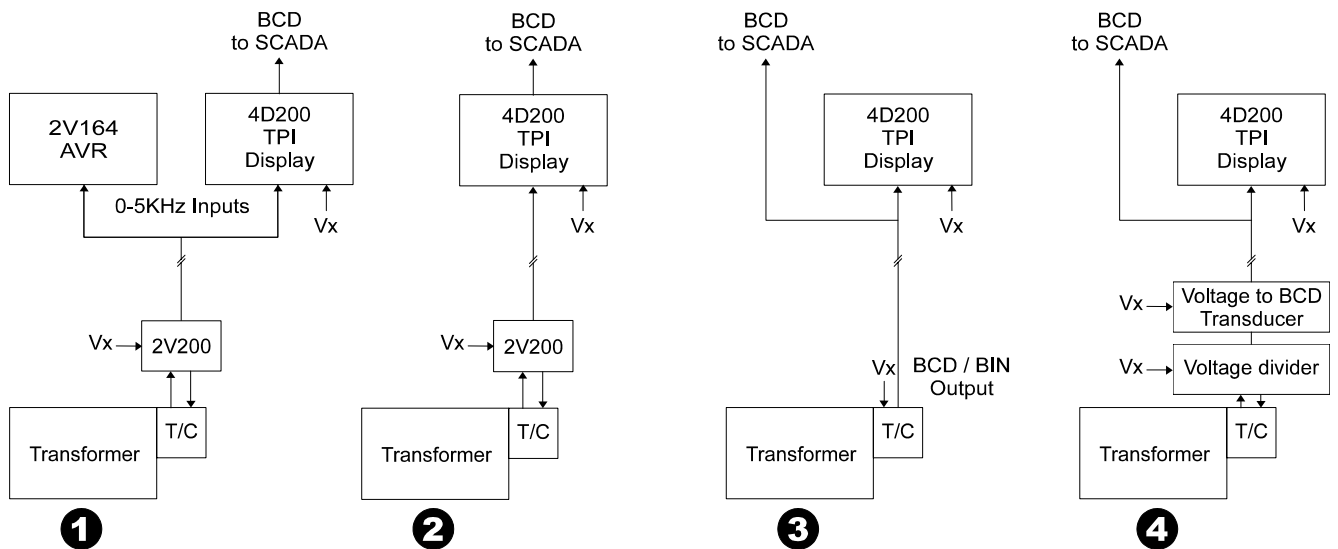

AUXILIARY POWER SUPPLY

Vx input: 12V DC
 Use separate Idec PS5R-x12 isolating power supply module to interface with AC or DC auxiliary supplies.

POWER CONSUMPTION

<4VA (3W)

4D200 INPUTS

Application examples 1 & 2

0-5KHz frequency input provided by the RMS 2V200 TPI transducer.

Application examples 3 & 4

BCD/BIN input direct from tap changer or voltage divider to BCD/BIN transducer. 50V DC or 110/125V DC input range may be specified.

BCD / BINARY SETTING

Default setting : BCD input
 Changing between BCD & Binary input setting is achieved by opening the case & setting a series of DIP switches in accordance with the 4D200 User Guide.

MAXIMUM TAP SELECTION

Where the 0-5KHz frequency input is employed the 4D200 TPI display module must be set with the maximum tap number. This is achieved by opening the case & setting a series of DIP switches in accordance with the 4D200 User Guide.

4D200 DISPLAY

2 x 7 segment 25mm red LED digits display the tap position over the range tap 1 to a maximum tap 30.

4D200 BCD OUTPUTS

Optional BCD output using clean relay contacts for interface to a SCADA system.

BCD OUTPUT CONTACT RATING Order code 4D200[A][C]

Make & carry

- 30A AC or DC (Limits L/R=40ms & 300V max.) for 0.2s
- 20A AC or DC (Limits L/R=40ms & 300V max.) for 0.5s
- 5A AC or DC continuously

Break (Limits 5A & 300V max.)

- 1,250VA AC resistive
- 250VA at 0.4PF AC inductive
- 75W DC resistive
- 30W DC inductive L/R = 40ms
- 50W DC inductive L/R = 10ms

Minimum recommended load

0.5W, 10mA or 5V minimum.

OPERATING TEMPERATURE RANGE

-5 to 55 degrees C.

INSULATION WITHSTAND

In accordance with IEC 255-5:
 2KV RMS between input & output. 1.2/50 5KV impulse input & output.

NOISE IMMUNITY

Withstands the high frequency interference test detailed in IEC 255-22-1.

4D200 Rear Panel Screw Terminals

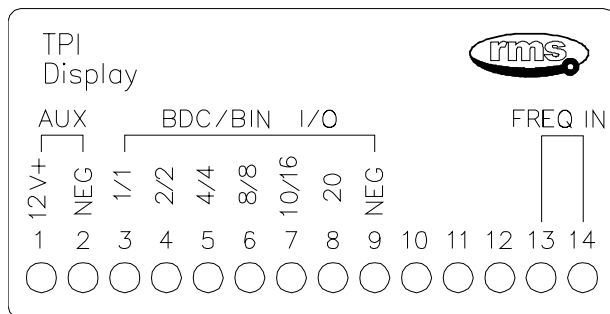

CASE DIMENSIONS & MOUNTING

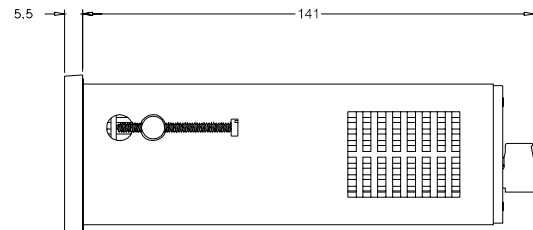
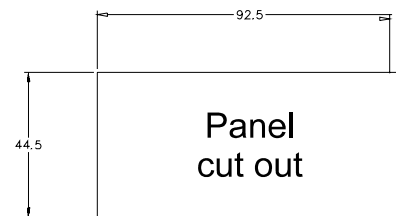
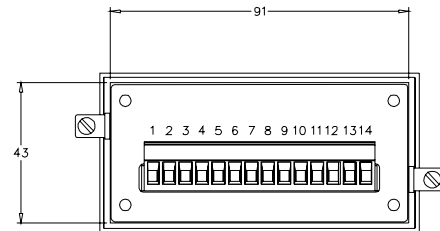
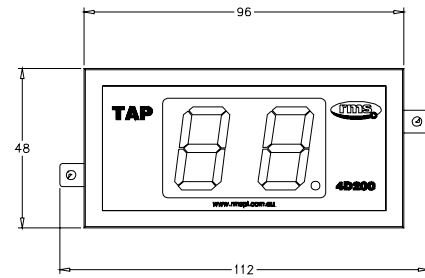

CASE TERMINALS

14 way plug in screw terminal block.

IDEC PS5R-x12 POWER SUPPLY MODULE

The Idec PS5R DIN rail mount power supply is suitable for providing the 12V DC auxiliary supplied required to operate the 4D200 TPI Display module.

- Vx input: 85 to 264V AC
- 105 to 370V DC
- Power output: 7.5, 15 or 30W continuous (Refer order codes)



PS5R Power Supply Module

Generate the required ordering code as follows: e.g. PS5R A12

PS5R

| |
|---|
| 1 |
| |

 12

1 OUTPUT POWER RATING

- A 7.5W version to power one 4D200 module
- B 15W version to power two or three 4D200 modules
- C 30W version to power four 4D200 modules

Ordering Information

4D200 TPI Display Module

Generate the required ordering code as follows: e.g. 4D200A

4D200

| |
|---|
| 1 |
| |

1 I/O INTERFACE SPECIFICATION

- A 0-5KHz frequency input version (Application 1 or 2)
- B [A] version with BCD output signaling (Application 1 or 2)
- C BCD/Binary input - 50V DC input (Application 3 or 4)
- D BCD/Binary input - 110/125V DC input (Application 3 or 4)

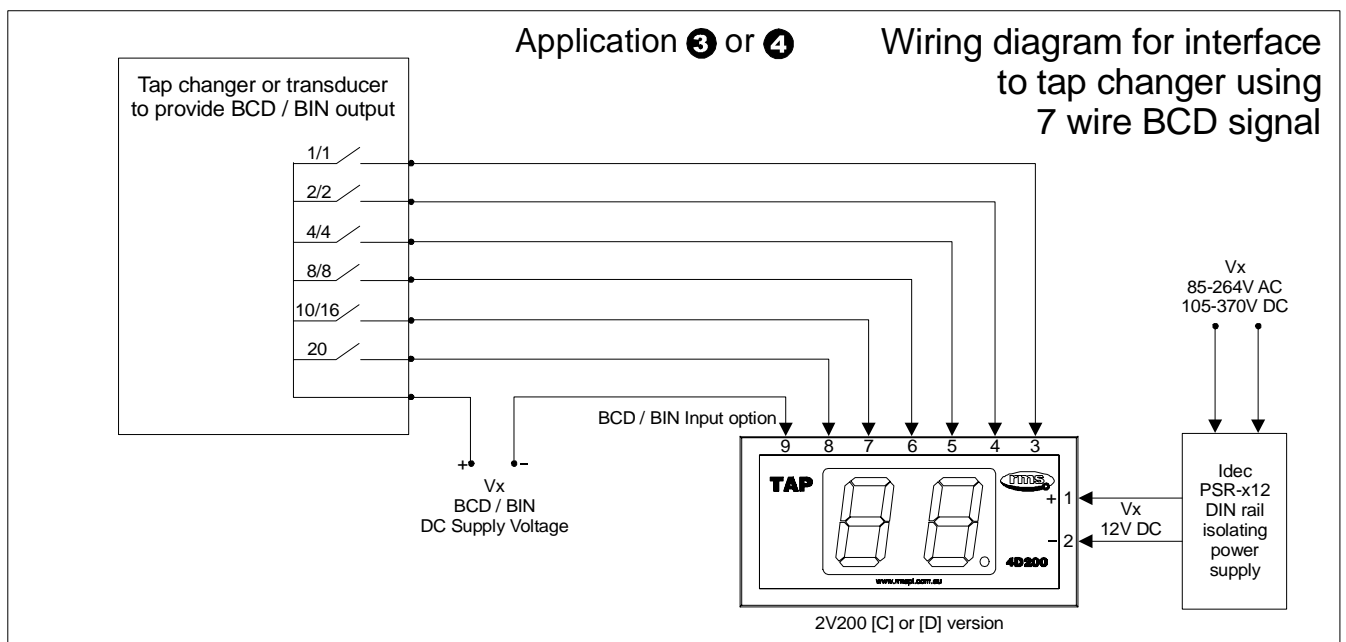
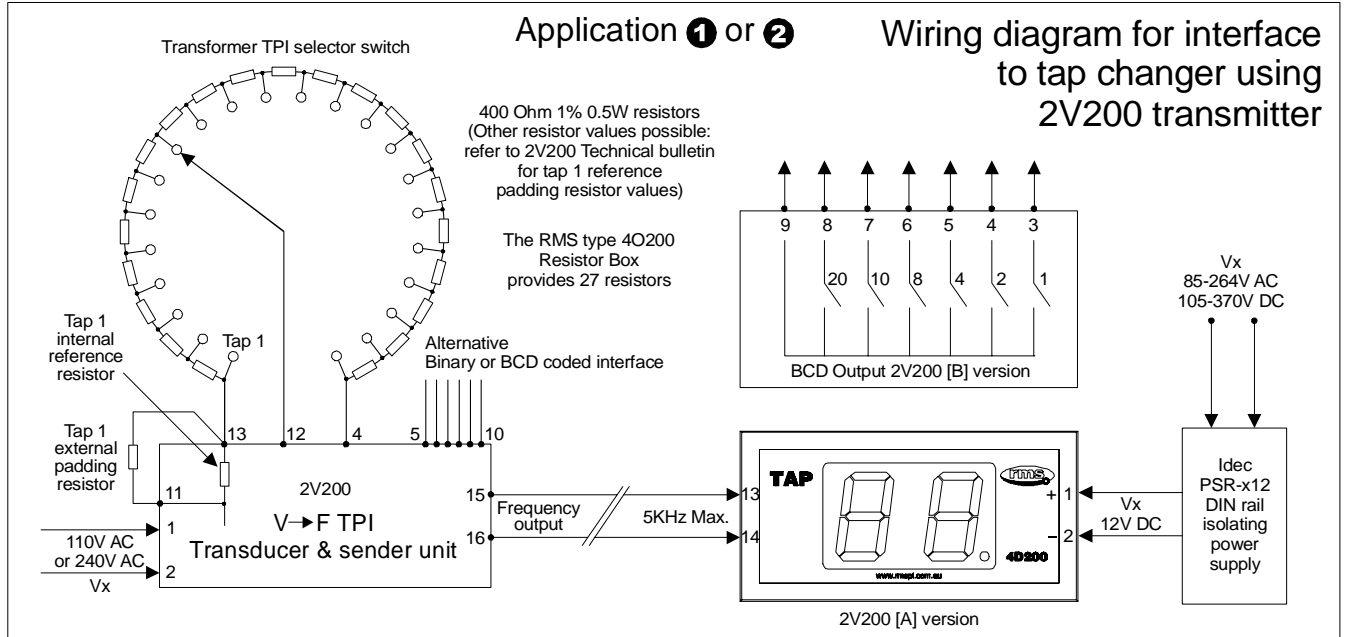

Installation

Handling of Electronic Equipment

A person's normal movements can easily generate electrostatic potentials of several thousand volts. Discharge of these voltages into semiconductor devices when handling electronic circuits can cause serious damage, which often may not be immediately apparent but the reliability of the circuit will have been reduced.

The electronic circuits of Relay Monitoring Systems Pty Ltd products are immune to the relevant levels of electrostatic discharge when housed in the case. Do not expose them to the risk of damage by withdrawing modules unnecessarily.

Each module incorporates the highest practicable protection for its semiconductor devices. However, if it becomes necessary to withdraw a module, the following precautions should be taken to preserve the high reliability and long life for which the equipment has been designed and manufactured.

1. Before removing a module, ensure that you are at the same electrostatic potential as the equipment by touching the case.
2. Handle the module by its front-plate, frame, or edges of the printed circuit board.
3. Avoid touching the electronic components, printed circuit track or connectors.
4. Do not pass the module to any person without first ensuring that you are both at the same electrostatic potential. Shaking hands achieves equipotential.
5. Place the module on an antistatic surface, or on a conducting surface which is at the same potential as yourself.
6. Store or transport the module in a conductive bag.

If you are making measurements on the internal electronic circuitry of an equipment in service, it is preferable that you are earthed to the case with a conductive wrist strap.

Wrist straps should have a resistance to ground between 500k – 10M ohms. If a wrist strap is not available, you should maintain regular contact with the case to prevent the build up of static.

Instrumentation which may be used for making measurements should be earthed to the case whenever possible.



Safety Section

This Safety Section should be read before commencing any work on the equipment.

Explanation of Symbols & Labels

The meaning of symbols and labels which may be used on the equipment or in the product documentation, is given below.

Caution: refer to product information



Caution: risk of electric shock

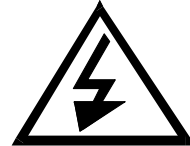

Functional earth terminal

Note: this symbol may also be used for a protective/safety earth terminal if that terminal is part of a terminal block or sub-assembly eg. power supply.





Unpacking

Upon receipt inspect the outer shipping carton or pallet for obvious damage.

Remove the individually packaged relays and inspect the cartons for obvious damage.

To prevent the possible ingress of dirt the carton should not be opened until the relay is to be used. Refer to the following images for unpacking the relay:



Inner packing carton showing front label detailing the customer name, order number, relay part number & description, the relay job number & packing date.

(Size 2 inner packing carton depicted)



Visit www.rmspl.com.au for the latest product information.

Due to RMS continuous product improvement policy this information is subject to change without notice. 4D200_Guide/lss B - 22/05/09



Relay Module Label Depicting Product Details & Wiring



Visit www.rmspl.com.au for the latest product information.

Due to RMS continuous product improvement policy this information is subject to change without notice. 4D200_Guide/lss B - 22/05/09



Storage & Handling

If damage has been sustained a claim should immediately be made against the carrier, also inform Relay Monitoring Systems Pty Ltd and the nearest RMS agent

When not required for immediate use, the relay should be returned to its original carton and stored in a clean, dry place.

Recommended Mounting Position

The relay should be mounted on the circuit breaker or panel to allow the operator the best access to the relay functions.

Relay Dimensions & Other Mounting Accessories

Refer drawing in Technical Bulletin. Relevant Auto Cad files & details on other accessories such as 19 inch sub rack frames, semi projection mount kits & stud terminal kits may be down loaded from:

<http://www.rmspl.com.au/mSeries.htm>



Visit www.rmspl.com.au for the latest product information.

Due to RMS continuous product improvement policy this information is subject to change without notice. 4D200_Guide/lss B - 22/05/09



Equipment Connections

Personnel undertaking installation, commissioning or servicing work on this equipment should be aware of the correct working procedures to ensure safety. The product documentation should be consulted before installing, commissioning or servicing the equipment.

Terminals exposed during installation, commissioning and maintenance may present hazardous voltage unless the equipment is electrically isolated.

If there is unlocked access to the rear of the equipment, care should be taken by all personnel to avoid electric shock or energy hazards.

Voltage and current connections should be made using insulated crimp terminations to ensure that terminal block insulation requirements are maintained for safety. To ensure that wires are correctly terminated, the correct crimp terminal and tool for the wire size should be used.

Before energising the equipment it must be earthed using the protective earth terminal, or the appropriate termination of the supply plug in the case of plug connected equipment. Omitting or disconnecting the equipment earth may cause a safety hazard.

The recommended minimum earth wire size is 2.5mm², unless otherwise stated in the technical data section of the product documentation.

Before energising the equipment, the following should be checked:

1. Voltage rating and polarity;
2. CT circuit rating and integrity of connections;
3. Protective fuse rating;
4. Integrity of earth connection (where applicable)

Equipment Operating Conditions

The equipment should be operated within the specified electrical and environmental limits.



Visit www.rmspl.com.au for the latest product information.

Due to RMS continuous product improvement policy this information is subject to change without notice. 4D200_Guide/Iss B - 22/05/09



Decommissioning & Disposal

Decommissioning: The auxiliary supply circuit in the relay may include capacitors across the supply or to earth. To avoid electric shock or energy hazards, after completely isolating the supplies to the relay (both poles of any dc supply), the capacitors should be safely discharged via the external terminals prior to decommissioning.

Disposal: It is recommended that incineration and disposal to water courses is avoided. The product should be disposed of in a safe manner.



Visit www.rmspl.com.au for the latest product information.

Due to RMS continuous product improvement policy this information is subject to change without notice. 4D200_Guide/lss B - 22/05/09



Maintenance

Mechanical Inspection

Relay Assembly

Inspect the relay for obvious signs of damage or ingress of moisture or other contamination.

Relay Module

Isolate the relay.

Care must be taken to avoid subjecting the relay element to static discharge which may damage or degrade sensitive electronic components.

Inspect the relay module for signs of any overheating or burn marks which may have been caused by overvoltage surge or transient conditions on the power supply or digital status inputs.

Defect Report Form

Please copy this sheet and use it to report any defect which may occur.

| | |
|---------------------------|----------------------|
| Customers Name & Address: | Contact Name: |
| | Telephone No: |
| | Fax No: |
| Supplied by: | Date when installed: |
| Site: | Circuit: |

When Defect Found

| | | | | |
|--|----------------|--------------------|----------------|----------------------|
| Date: | Commissioning? | Maintenance? | Systems Fault? | Other, Please State: |
| Product Part No: | | | Serial Number: | |
| Copy any message displayed by the relay: | | | | |
| Describe Defect: | | | | |
| Describe any other action taken: | | | | |
| Signature: | | Please Print Name: | | Date: |

For RMS use only

| | | | | | |
|----------------|---------------|---------------|--------------------|----------------|---------------|
| Date Received: | Contact Name: | Reference No: | Date Acknowledged: | Date of Reply: | Date Cleared: |
|----------------|---------------|---------------|--------------------|----------------|---------------|



Visit www.rmspl.com.au for the latest product information.

Due to RMS continuous product improvement policy this information is subject to change without notice. 4D200_Guide/lss B - 22/05/09

Australian Content

Unless otherwise stated the product(s) quoted are manufactured by RMS at our production facility in Melbourne Australia. Approximately 60% of our sales volume is derived from equipment manufactured in house with a local content close to 90%. Imported components such as semi-conductors are sourced from local suppliers & preference is given for reasonable stock holding to support our build requirements.

Quality Assurance

RMS holds NCSI (NATA Certification Services International), registration number 6869 for the certification of a quality assurance system to AS/NZS ISO9001-2000. Quality plans for all products involve 100% inspection and testing carried out before despatch. Further details on specific test plans, quality policy & procedures may be found in section A4 of the RMS product catalogue.

Product Packaging

Protection relays are supplied in secure individual packing cardboard boxes with moulded styrene inserts suitable for recycling. Each product & packing box is labeled with the product part number, customer name & order details.

Design References

The products & components produced by RMS are based on many years of field experience since Relays Pty Ltd was formed in 1955. A large population of equipment is in service throughout Australia, New Zealand, South Africa & South East Asia attesting to this fact. Specific product & customer reference sites may be provided on application.

Product Warranty

All utility grade protection & auxiliary relay products, unless otherwise stated, are warranted for a period of 24 months from shipment for materials & labour on a return to factory basis. Repair of products damaged through poor application or circumstances outside the product ratings will be carried out at the customer's expense.

Standard Conditions of Sale

Unless otherwise agreed RMS Standard Terms & Conditions (QF 907) shall apply to all sales. These are available on request or from our web site.



Relay Monitoring Systems Pty Ltd

6 Anzed Court, Mulgrave, Victoria 3170, AUSTRALIA

Tel: 61 3 9561 0266 Fax: 61 3 9561 0277 Email: rms@rmspl.com.au Web: www.rmspl.com.au